

2020

2021

# REFERENCE GUIDE

## TABLE OF CONTENTS

<b>I</b>	Indexes 2 - 6	<b>W</b>	Warewashing 158 - 165
<b>U</b>	Useful Guides 7 - 19	<b>J</b>	Janitorial 166 - 174
<b>R</b>	Refrigeration Equipment 20 - 44	<b>F</b>	Furniture 175 - 184
<b>E</b>	Equipment 45 - 73	<b>B</b>	Bar 185 - 195
<b>C</b>	Countertop Equipment 74 - 94	<b>B</b>	Buffet & Catering 196 - 202
<b>F</b>	Food Prep 95 - 105	<b>B</b>	Beverage Service 203 - 211
<b>K</b>	Kitchen 106 - 145	<b>T</b>	Tabletop 212 - 240
<b>S</b>	Storage & Transport 146 - 157	<b>S</b>	Supplier Spotlight 241 - 304



This catalog is representative of the merchandise we carry. It is not practical to show every item from every manufacturer. If you do not see what you are looking for, please inquire! For accurate and current pricing, please contact us. We are not responsible for omissions or typographical errors. Copyright 2020 Excell Foodservice Equipment Dealer Network. Printed in the USA.

# PRODUCT INDEX

Air Curtain - Disher

## A

Air Curtain	169
Air Mover	174
Airpot	210
Apparel	144, 145
Appliance Bulb	171
Apron	142, 144, 271

## B

Back Bar Cooler	36-39, 248
Baffle Grease Filter	68
Bake Mat	117
Bakery Case	246
Bakery Display Case	33, 34
Bakery Oven	55
Bamboo Picks	200
Bandage	142
Bandage Dispenser	142
Bar Beaker	288
Bar Flask	288
Bar Kit	189
Bar Knife	189
Bar Liner	173
Bar Mop Towel	192
Bar Sink	195
Bar Spoon	187, 189
Bar Workstation	194
Barstool	175, 176, 179, 180, 182, 283-286
Basket Liner	213
Basting Spoon	266
Beaker	288
Beanie	272
Beer Froster	248
Beer Tap Plug	193
Bench Scraper	114
Beverage Dispenser	204, 205, 210, 211, 293
Beverage Dispenser Cover	212
Beverage Tub	201
Blender	185, 186, 265, 289, 290
Blender Station	194
Booth	283
Bottle Cooler	35-37, 248
Bottle Filler	116
Bottle Opener	189
Brazier	137, 139, 269
Briquettes	88
Broiler	48
Broom	280, 281
Buffet Display	296
Bun Pan	116
Bun Warmer	91
Bus Tub	275
Bus Tub Cover	212
Bussing Cart	275
Butane Fuel	198, 199
Butane Lighter	198
Butane Stove	198, 199
Butter Warmer/Dispenser	93

## C

Cake Pan	117
Can Opener	130
Can Rack	157
Candle	218
Cap	144
Cart	150, 152, 153
Cart Skirting	212
Casserole	214, 215
Caster	65, 72, 150
Chafer	198, 199
Chair	175, 176, 179-183, 283-286
Chaise	181
Charbroiler	48, 84-88, 257, 258
Check Rack	140
Cheese Grater	115
Cheese Shaker	121
Cheese Warmer/Dispenser	93
Cheesemelter	48
Chef Base	27, 28
Chef Coat	272, 273
Chef Pants	145, 272
Chef's Jacket	145
Chef's Torch	198, 199
Chilling Paddle	122
Chopper	104, 105
Churro Maker	259
Cigarette Receptacle	167
Circle Air Oven	54
Citrus Squeezer	192
Cleaner	166
Cleaning Pail	167, 282
Cocktail Kit	189
Cocktail Pick	187
Cocktail Shaker	188, 189
Cocktail Strainer	187, 189
Cocotte	140
Coffee Brewer	209-211, 297
Coffee Server	216
Coffee Urn	297
Colander	131, 133
Cold Beverage Dispenser	204, 205
Cold Food Table	253
Combi Oven	50, 250
Compartment Sink	195, 278
Condiment Dispenser	92, 93
Condiment Holder	190
Condiment Refiller	116
Control Panel	69
Convection Oven	49-54, 82, 83, 259
Conveyor Oven	81
Cook's Shirt	273
Cook's Fork	106, 107, 114
Cookware	137-140, 269, 270
Cooler Cart	201
Corkscrew	189
Counterline Stand	84
Countertop Merchandiser	256

Countertop Organizer	206
Crate	201
Creamer	216
Crème Brûlée	215
Crock	291
Cup & Lid Holder	206
Cup Dispenser	207, 208
Cup Dispensing Cart	206
Cupcake Pan	117
Cut Resistant Glove	111, 112
Cutlery	106-109, 266
Cutlery Polisher	162
Cutlery Rack	276
Cutting Board	110, 111
Cutting Board Brush	280

## D

Decorating Tip	118
Deli Case	245-247
Deli Pan	202
Delivery Bag	198
Dicer	102, 105
<b>Dinnerware</b>	202, 219-227, 300, 301, 303, 304
Alpine by Vertex China	224
Alpine White by Crestware	304
Argyle & Catalina by Vertex China	225
Bay Point by Crestware	303
Brighton by International Tableware	221
Bristol by International Tableware	220
Dallas Ware by Carlisle	301
Dover by International Tableware	222
Dover White by Crestware	304
Dresden by International Tableware	221
Gathering by Carlisle	300
Graham by Thunder Group	226
Grass Valley by Vertex China	224
Great Wall by CAC China	223
Grove by Carlisle	300
Jazz by Thunder Group	226
Kingline by Carlisle	301
London Moonstone by Vertex China	225
Luna by International Tableware	219
Mingle by Carlisle	300
Opera by Vertex China	224
Orbit by Vertex China	225
Quad by International Tableware	221
Settlement Bistro by G.E.T.	202
Slate by World Tableware	223
Slope by International Tableware	219
Torino by International Tableware	222
Urban Mill by G.E.T.	227
Dipperwell Faucet	165
Direct Draw Cooler	38, 39
Dish Cabinet	274
Dish Caddy	161
Dish Rack	160, 161, 276
Dish Rack Dolly	160, 161, 276
Disher	114

# PRODUCT INDEX

Dishwasher - Grill Brush

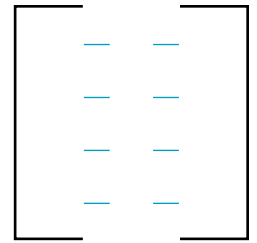

Dishwasher	158-160, 277-279
Dishwasher Test Label	162
Dishwasher Test Plate	162
Dishwashing Apron	142
Dishwashing Gloves	142
Display Case	243
Displayware	292
Door	175
Double Boiler	270
Dough Divider/Rounder	98
Dough Docker	120
Dough Pan	118
Dough Scraper	118
Dough Sheeter	97
Draft Beer Dispenser	38, 39
Drain Shelf	131, 267
Drainboard	194
Dredge	120, 121
Drinking Jar	239
<b>Drinkware</b>	234-240, 302, 303
Alibi by Carlisle	302
Aruba by Libbey	237
Barbary Beer by Anchor Hocking	239
Cabernet by Cardinal	236
Cirq by Cambro	240
Clarisse by Anchor Hocking	239
Contour by Libbey	237
Distill Whiskey by Libbey	237
Drinking Jar by Libbey	239
Embassy by Libbey	235
Grand Cépages by Cardinal	236
Growler by Libbey	239
Lido by Cambro	240
Louis by Carlisle	302
Mingle by Carlisle	303
Mixing Glasses by Anchor Hocking	238
Modernist by Libbey	237
New Orleans by Anchor Hocking	239
Paneled Steins by Anchor Hocking	238
Perception by Libbey	234
Perfect Portions by Anchor Hocking	239
Pilsners by Anchor Hocking	238
Pub Glasses by Anchor Hocking	238
Reality by Anchor Hocking	238
Series V by Libbey	235
Stackable Tumblers by Carlisle	302
Stemless by Libbey	234
Vina by Libbey	234
Drop-In Cold Pan	249
Ductwork	69
Dunnage Rack	154
Dust Pan	280, 281

<b>E</b>	
Egg Slicer	115
Equipment Stand	71, 72, 84
Equipment Stand, Refrigerated	242
Equipment Wheel Positioning	66, 67
Espresso Machine	209, 210, 297

<b>F</b>	
Fajita Platter	214
Fan	69
Fast Food Tray	299
Faucet	164, 165
Film Wrapper	134
Film/Foil Wrap Station	134
Fish & Poultry Case	245
Flask	288
<b>Flatware</b>	227-233
Accolade by Walco	232
Arbor Rose by Oneida	233
Athenian by Walco	230
Atlantic by Thunder Group	228
Barclay by Walco	232
Bosa Nova by Walco	231
Chateau by Oneida	233
Dakota Satin by Thunder Group	228
Diamond by Thunder Group	228
Domilion by Thunder Group	228
Dominion by Walco	232
Dramatique by Walco	230
Elizabeth by Thunder Group	228
Esquire by Thunder Group	228
Fanfare by Walco	232
Goddess by Walco	231
Hyannis by Walco	231
Illustra by Walco	231
Jewel by Thunder Group	228
Joreen by Walco	231
Legend by Thunder Group	228
Modernaire by Walco	230
Napa by Walco	231
Pacific Rim by Walco	231
Patrician by Walco	232
Phoenix by CAC China	227
Poise by Walco	232
Prime by CAC China	227
Royal Bristol by Walco	232
Salem by Thunder Group	229
Sea Shell by Thunder Group	229
Simplicity by Thunder Group	229
Soho by Walco	231
Sonnet by Walco	232
Soprano by Walco	230
Sunflower by Thunder Group	229
Tahoe by Thunder Group	229
Vogue by Walco	230
Wilshire by Thunder Group	229
Windsor by Thunder Group	229
Windsor by Walco	232
York by Thunder Group	229
Flatware Basket	160, 161
Flatware Caddy	201
Flatware Retriever	167
Floor Cleaning Machine	174
Floor Drain Trap Seal	162

Floor Dryer	174
Floor Mat	173
Floor Scrub Brush	281
Floor Sweep	280
Floor Trough	172
Flour Sifter	118
Folding Table	72
Food Carrier	198
Food Pan & Lid	131, 132, 267
Food Pan, Cold	196, 292
Food Prep Machine	263
Food Prep Table	29
Food Processor	98-100
Food Storage Container & Lid	130-133, 135, 136, 268
Food Warmer	77-80, 93, 255, 256
Freezer Merchandiser	21
Freezer, Reach-In	20, 22-25
Freezer, Undercounter	26-28
Freezer, Walk-In	40, 41
Frozen Beverage Dispenser	204
Frozen Drink Machine	203, 204
Fruit Fly Trap	193
Fry Basket	213, 298
Fry Cone	213
Fry Cup	201, 298
Fry Cutter	104
Fry Pan	137-139, 214, 269
Fry Pan Skillet	215
Fryer	60-63, 89, 251, 259
Fryer Basket	64, 65
Fryer Basket Divider	65
Fryer Cleaner	166
Fryer Filter	60, 64

<b>G</b>	
Garnish Station	190
Gas Connector	66, 67
Gelato Case	245
Glass Door Merchandiser	20, 21, 34, 242
Glass Filler	161, 165
Glass Polisher	193
Glass Rack	160, 161, 276
Glass Rimmer	289
Glass Storage Bin	195
Glass Washer	193
Glasswasher	159
Glide	177
Gloves, Dishwashing	142
Gloves, Disposable	143
Grab-n-Go Case	246, 247
Grater Attachment	263
Gravy Boat	214
Griddle	83-88, 257, 258
Griddle Rail	88
Griddle Stand	29
Griddle Top, Add-On	48
Grill Brush	280

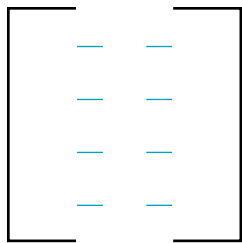

# PRODUCT INDEX

## Grill Scraper - Platter

Grill Scraper	114
Grill Stand	296
Grill, Mobile	59
Growing Cabinet	58
Growler	239
Guest Check	213
Gyro Machine	89, 257

<b>H</b>	
Hand Dryer	169
Hat	144
Heat Lamp	78, 79, 296
Heat Lamp Bulb	171
Heat Seal Wrapper	134
Heated Cabinet	58, 252
Heated Merchandiser	256
Heater	69
Heater/Proofer	57, 59
Herb Cabinet	58
Holding Cabinet	58
Holloware	216
Hood Filter	68
Hose	173
Hot Dog Roller Grill	91
Hot Dog Steamer	91
Hot Food Table	70, 252-254
Hot Pad	141
Hot Plate	83, 84, 86
Hot Water Hose & Nozzle	173

<b>I</b>	
Ice Bin	195
Ice Bucket	189
Ice Cream Cone Dispenser	206
Ice Cream Machine Cleaner	166
Ice Cream Server	292
Ice Machine	42-44
Ice Machine Cleaner	166
Ice Mold	288
Ice Pick	188
Ice Scoop	122, 190
Ice Scoop Holder	122
Ice Storage Bin	42
Ice Tongs	189
Ice Tote	122
Ice Wand	122
Iced Tea Dispenser	204
Iced Tea Dispenser Cleaner	166
Immersion Blender	100-102, 265
Immersion Circulator	260
Induction Chafer	198
Induction Range	198, 294, 295
Induction Warmer	294, 295
Ingredient Bin	146, 147
Insulated Beverage Dispenser	210, 211, 293
Insulated Food Pan	292
Insulated Pan Carrier	197, 293, 294

<b>J</b>	
Jacket	145
Janitor Cabinet	172
Jar	239
Jigger	188, 189
Juice Dispenser	203
Juicer	103, 188, 198, 264

<b>K</b>	
Keg Cart	150
Keg Cooler	38, 39
Keg Dolly	150
Kettle	55
Knife Rack	112
Knife Sharpener	111-113

<b>L</b>	
Label	133, 134
Label Dispenser	134
Ladle	196, 200, 266
Lava Rocks	88
Leveler	177
Lid Holder	208
Lid Organizer	207
Light Bulb	171
Liner Tissue	213
Liquor Display	194
Liquor Pourer	189, 191, 289
Lock	154
Locker	154
Lounge Chair	181
Loveseat	181
Lubricant	166

<b>M</b>	
Makeup Air	69
Mandoline	105
Mat Washing Cabinet	172
Measuring Spoon	115
Meat Grinder	95, 261
Meat Saw	95
Merchandiser, Air Curtain	33
Merchandiser, Combination	246
Merchandiser, Countertop	256
Merchandiser, Freezer	21
Merchandiser, Heated	90, 256
Merchandiser, Refrigerated	20, 21, 34, 242-244, 246, 256
Metal Polish	166
Microwave	74, 75
Mini Cookware	214
Mixer	96, 97, 262, 263
Mixer Attachment	261
Mixer, Handheld	100-102
Mixing Bowl	118
Mixing Glass	189
Mixing Paddle	189

Mixing Spoon	114
Mobile Cabinet	156
Molcajete	299
Mop	167, 281
Mop Bucket/Wringer Combo	281
Mop Sink	172
Mop Stick	281
Moscow Mule Mug	189
Motion Floor Machine	174
Muddler	188, 189
Muffin Pan	117
Multipurpose Oven	82, 83

<b>N</b>	
Nacho Chip Warmer	93
Napkin Dispenser	208
Nozzle	173

<b>O</b>	
Oven	49
Oven Brush	120, 280
Oven Mitt	140, 141
Oven, Countertop	81-83
Oven/Proofer	55
Overshelf	71

<b>P</b>	
Pail, Cleaning	167, 282
Pail, Serving	201
Pan Carrier & Accessories	197, 293, 294
Pan Carrier Dolly	197
Pan Grabber	140, 141
Pan Rack	156, 157
Pan Rack Cover	156
Panini Grill	76, 77
Pasta Cook & Rinse Station	63
Pasta Cooker	63, 270
Pasta Machine	98
Pastry Bag	118
Pastry Tip	118
Pecan Roll Pan	117
Peeler	115
Pepper Mill	217
Pick	187
Picks	200
Pie Server	120, 200
Pineapple Corer	103
Pitcher	298
Pizza Cutter	120
Pizza Delivery Bag	120
Pizza Dough Box & Dolly	121
Pizza Merchandiser	90
Pizza Oven	54, 81, 82, 259
Pizza Pan	119
Pizza Peel	120, 121
Pizza Prep Table	32, 242
Pizza Screen & Rack	119
Pizza Tray & Stand	119
Platter	201

# PRODUCT INDEX

## Podium - Work Table

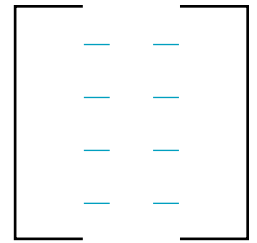

Podium.....	178	Serving Tray .....	213, 299	Tilting Skillet .....	55
Popcorn Popper .....	94	Sharpening Steel .....	106, 108, 109	Timer.....	125, 126
Portion Cup & Lid Holder .....	206	Sheet Pan .....	116, 117	Toaster .....	80, 81, 255
Portion Spoon.....	115	Sheet Pan Cover.....	117	Toilet Paper Dispenser.....	170
Pot & Pan Scrubber.....	278	Shelf Liner.....	173, 193	Tomato Slicer.....	104, 105, 265
Pourer.....	189, 191, 289	Shelf, Buffet .....	296	Tongs.....	114, 115, 196, 200, 291
Pourover Steamer .....	297	Shelving.....	147-151, 155	Towel Dispenser.....	170
Power Drive Unit .....	261	Shirt.....	144	Tray .....	299
Pre-Rinse & Accessories.....	162, 164, 165	Shredder Attachment .....	261	Tray Stand.....	213
Probe Wipes.....	125	Silicone Bake Mat .....	117	Tray Stand Cover .....	212
Produce Case .....	244	Sink .....	163	Tray Washer .....	279
Produce Saver.....	130	Sizzle Skillet .....	214	Turner.....	114, 200
<b>R</b>		Skillet .....	138	Twist Waste Valve .....	165
Ramekin.....	201, 299	Slicer.....	95, 96, 261, 262	<b>U</b>	
Range .....	251	Snack Oven .....	81, 82	Umbrella .....	184, 287
Range, Restaurant.....	45-47	Sneeze Guard .....	70	Underbar Equipment .....	194, 195
Red Meat Case .....	245	Soap Dispenser .....	170, 171	Urn.....	199
Refrigerated Display Case .....	33, 34	Soft Serve Machine.....	44	Utensil Rack.....	155
Refrigerated Equipment Stand.....	242	Soup Crock.....	215	Utility Cart .....	152, 153, 275
Refrigerated Merchandiser .....	20, 21, 34,	Soup Warmer.....	77-80	<b>V</b>	
.....	242-244, 246, 256	Sous Vide .....	260	Vacuum .....	174
Refrigerator, Countertop Prep .....	28	Spatula .....	114	Vacuum Pack Bags .....	260
Refrigerator, Reach-In .....	20, 22-25	Speed Rail.....	192, 194	Vacuum Pack Machine .....	99, 260
Refrigerator, Undercounter .....	26-28	Spindle Drink Mixer .....	265	Vegetable Slicer .....	104, 105
Refrigerator, Walk-In.....	40, 41	Spray Bottle .....	166	Vegetable Slicer Attachment .....	261
Refrigerator, Worktop.....	27	Spray Paint .....	166	Ventilation .....	69
Rethermalizer .....	64, 256	Squeegee .....	281	Ventless Hood.....	68
Rice Cooker/Warmer .....	255	Squeeze Bottle .....	116	Vertical Broiler .....	89, 257
Roasting Dish .....	140	Steak Knives .....	233	<b>W</b>	
Rolling Pin.....	118	Steam Table .....	252-254	Waffle Maker .....	77
Rotating Rack Oven .....	54, 55	Steam Table Pan & Lid.....	136	Wait Station.....	178
Rotisserie Glove.....	140	Steamer.....	56	Walk-In.....	40, 41, 249
<b>S</b>		Steamer Basket .....	270	Walk-In Door .....	41
Salad Spinner .....	102, 103	Steamer, Pourover.....	297	Wall Shelf .....	155
Salamander .....	48	Stirrer .....	187	Warmer .....	77-80
Salsa Dish.....	299	Stock Pot.....	137, 139, 270	Waste Container .....	168, 169
Salt & Pepper Shaker.....	217	Storage Cabinet.....	274	Waste Container Cover.....	212
Salt Mill .....	217	Strainer .....	187	Waste Container Dolly.....	167-169, 282
Sandwich Grill.....	76, 77	Straw Dispenser.....	207	Water Dispenser.....	44
Sandwich/Salad Prep Table.....	29-31	Strip Heater .....	78, 79	Water Filter.....	56
Sanitizer Test Strips .....	122	Sugar Bowl .....	216	Water Line.....	162
Sanitizing Pail .....	282	Sweep .....	280	Water Meter.....	124
Sauce Pan.....	137, 139, 214, 269	Sweeper.....	174	Water Pitcher.....	216
Sauce Pot .....	270	<b>T</b>		Water Test Strips .....	122
Saucier.....	214	Table .....	179, 181-183, 286, 287	Wedger.....	103
Sauté Pan .....	137, 139	Table Base.....	177, 180, 182	Welsh Rarebit .....	215
Scale .....	127-129	Table Cover.....	212	Wheatgrass Juicer.....	264
Scrub Brush .....	280	Table Lighting .....	217, 218	Wine Cabinet.....	35
Sealant.....	166	Table Skirting & Accessories.....	212	Work Table .....	71-73
Security Cage .....	147	Table Top.....	177, 178, 180, 182, 283		
Security Cart .....	152, 153	Table Topper.....	212		
Serving Basket .....	213, 298	Tabletop Display.....	296		
Serving Board .....	202	Taco Holder .....	298		
Serving Fork.....	200	Take-Away Cone.....	213		
Serving Skillet.....	215	Tea Pot .....	216		
Serving Spoon.....	114, 196, 200, 291	Test Strips.....	122		
		Thermometer.....	123-126		

# SUPPLIER INDEX

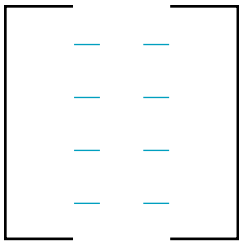

## A

Admiral Craft.....24, 33, 45, 62, 85, 96  
 Advance Tabco.....70  
 Aero.....274  
 AllPoints.....48, 67, 68, 88, 122, 166, 171, 177  
 American Metalcraft.....288, 298  
 Ammex.....143  
 Anchor Hocking.....238, 239  
 Anets.....61, 63, 87  
 Arctic.....249  
 Arctic Air.....25, 28, 38  
 Astra.....297  
 Atosa.....20, 25, 28, 31, 33, 34, 42, 54, 59, 62

## B

Bakers Pride.....53, 82  
 Bally.....41  
 Bar Maid.....103, 150, 162, 186, 193  
 Barfly Mixology.....187, 188  
 Bevles.....59  
 Bissell.....174  
 Blakeslee.....158  
 Blodgett.....49-51  
 Browne.....137, 138, 141, 200  
 Bunn.....210

## C

CAC China.....223, 227  
 Cactus Mat.....173  
 Cambro.....131-133, 147, 153, 155, 161, 197, 213, 240  
 CaptiveAire.....69  
 Cardinal.....236, 238  
 Carlisle.....267, 268, 275, 276, 280,  
 .....282, 289, 291-294, 298-303  
 Carter-Hoffman.....58, 93  
 Castle.....251, 257  
 Cecilware.....86, 87  
 Champion.....277  
 Chase Doors.....41, 175  
 Chef Master.....103, 198  
 Chef Revival.....144, 145  
 Chef Specialties.....217  
 Chef Works.....271-273  
 Chef's Choice.....113  
 CMA Dishmachines.....159, 160  
 Co-Rect (Crown Brands).....189, 190  
 Comark.....123, 126  
 Continental Refrigerator.....22, 27, 29, 30,  
 .....32, 35, 36, 38  
 CookTek.....77  
 Crestware.....258, 265, 266, 269, 270,  
 .....275, 276, 282, 303, 304  
 Crown.....56  
 Curtron.....41, 169, 175

## D

DHC Furniture.....283, 285  
 Dispense-Rite.....206  
 Dormont.....66  
 Doyon.....54, 97  
 Dynamic.....101, 102

## E

Eastern Tabletop.....296  
 Emu.....286, 287  
 Eurodib.....35, 42, 77, 89, 95, 96, 99, 158, 203

## F

Federal Industries.....243  
 Fisher.....165  
 Flash Furniture.....179  
 FMP.....65, 88, 126, 129  
 Focus Foodservice (Crown Brands).....65, 72, 103,  
 .....114, 115, 117, 130, 150, 155, 192, 205, 211  
 Fogel USA.....242, 248

## G

G.E.T.....196, 202, 213, 227, 240  
 General.....75, 96  
 German Knife.....95  
 Global Solutions.....82, 83, 90  
 Globe.....258, 259, 261, 262, 265  
 Grindmaster Cecilware.....62, 89, 204, 209  
 Grosfillex.....180-184

## H

Hamilton Beach.....260, 264, 265, 289, 290  
 Hatco.....255, 295  
 Hollowick.....199, 217, 218  
 Hoshizaki.....25, 26, 31, 42-44  
 Howard-McCray.....244, 245  
 Hydra-Kool.....246, 247

## I

Impact.....166, 169, 171  
 Imperial.....45, 48, 53, 63, 83  
 Insinger.....278, 279  
 International Tableware.....215, 219-222

## J

John Boos.....73, 110, 172  
 John Ritzenthaler.....141, 142, 144, 192  
 Johnson-Rose (Crown Brands).....71, 117,  
 .....160, 163, 178

## K

Klinger's Trading.....254, 274  
 Kold-Draft.....43  
 Krowne.....65, 67, 72, 150, 162-164, 194, 195

## L

Lang.....86  
 LaRosa.....242, 249  
 Legion.....55  
 Libbey.....234, 235, 237, 239

## M

MagiKitch'n.....59, 88  
 Maximum.....25, 43, 44  
 Mercer Culinary.....106, 107, 114

## N

National Checking.....134, 213  
 Nemco.....76, 78, 90-92, 99, 104, 105, 116  
 Nexel.....148-150, 153  
 Norlake.....20, 22, 26, 27, 30, 32, 35, 37, 38, 40  
 Nu-Vu.....55, 82

## O

O-Cedar Commercial.....281  
 Oak Street.....283, 284  
 Omega.....203, 233

## P

Pitco.....60, 61, 63, 64  
 Precision Pour.....289  
 Proctor Silex.....255, 297

## Q

Quantum Foodservice.....151, 152

## R

Radius.....212  
 Royal Industries.....72, 118-121, 136, 139,  
 .....150, 155, 163, 167, 169, 175-178, 213  
 Rubbermaid.....130, 146, 168

## S

San Jamar.....110, 112, 122, 126, 129, 134, 140,  
 .....142, 167, 170, 190, 193, 198, 207, 208  
 Seco Select.....252  
 Sharp.....74  
 Southbend.....46-48, 51, 52, 84  
 Spaceman.....44, 203  
 Spill-Stop.....191  
 Star.....76, 81, 85, 89, 91, 93, 94

## T

TableCraft.....116, 190, 192, 200, 201, 205, 214  
 Taylor Precision.....124, 125, 127-129, 162, 192  
 Thunder Group.....121, 135, 136, 146,  
 .....202, 226, 228, 229  
 Tomlinson.....80, 81, 90, 214  
 True.....21, 23, 26, 28, 29, 31-33, 37, 39  
 Turbo Air.....21, 24, 27, 29, 34, 36, 39, 75

## U

U.S. Cooler.....40  
 Univex.....55, 83, 96-98  
 Uniworld.....257, 259, 261, 263, 264  
 UNOX.....250  
 Update International (Crown Brands).....103, 105,  
 .....115, 116, 130, 198, 201, 202, 210

## V

Vertex China.....224, 225  
 Victorinox.....109, 111, 121  
 Vollrath.....252, 253, 256-261, 263, 266, 269, 294

## W

Walco.....199, 216, 230-233  
 Waring.....77, 80, 100, 185, 196  
 Wells.....68  
 Winco.....64, 75, 79, 89, 105, 109-112,  
 .....116, 121, 130, 139, 142, 144,  
 .....146, 153, 156, 167, 196, 199, 214  
 Winholt.....57, 134, 154, 156, 157, 162, 163  
 World Tableware.....223

## Z

Zwilling J.A. Henckels.....108, 112, 140

Produced by CFI Marketing - Jacksonville, FL 2020

# STRONGER TOGETHER

The Power of a Buying Group  
& How We Work for You

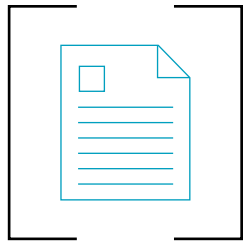

We are backed by a Buying Group—a combined nationwide network of 487 foodservice equipment dealers and suppliers. When you buy from our restaurant equipment company, you're supporting a local business and positively impacting our community.

## What is a buying group?

"A buying group is an organization made up of businesses that band together so they can negotiate as a larger group with vendors to receive better pricing and terms on goods and services."

Purchasing from our dealership allows you peace of mind knowing that you are getting the best value and the correct equipment for your foodservice operation.

I am a leader in the culinary equipment marketplace with the goal of providing solutions and services to fit your needs.

## Our Commitment to You:

### People First

1

You're more than an order number, and our customer-centric approach is just one of the many ways we will leave you with more time to focus on your operations. When you buy from us, you'll never have to worry about damaged or non-functioning equipment, or worse, equipment that won't fit through the door. We are focused on your success and provide personalized, hands-on service to the very last mile.

### Purchasing Power

2

Because of our membership with a buying group, you have access to the most competitive pricing in the industry (so there's no need to sacrifice great customer service for a lower price). With an extensive product selection from the nation's leading manufacturers, you're sure to find the best-suited products for your operation.

### Relentless Improvement

3

We take part in live, hands-on vendor training and receive access to the most robust online education and training portals in the industry.

With a strong pulse on industry trends, and armed with an array of marketing and educational resources, we promise to keep you at the forefront of industry products and innovations. We are equipped to address your pain points more efficiently and effectively than ever before.

### Think Forward

4

A partnership with our dealership guarantees you are connected to a local expert who keeps you at the forefront of industry trends and emerging technology to help your business operations run more efficiently.

### Work Smart

5

Don't get lost in the details. Let us shoulder the burden so you can focus on running your kitchen. Ask us about the full spectrum of value-added services we offer.



Our company is a proud member of a foodservice equipment and supplies buying group. Our nationwide network of foodservice equipment dealers & suppliers are leaders in their marketplace whose goals are to provide solutions and service the needs of end-users.

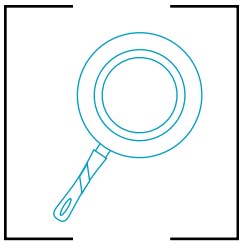

# PAYING IT FORWARD

About Our Partnership  
with Cooking Up Better Lives



We are proud supporters of Cooking Up Better Lives, a non-profit focused on donating foodservice equipment and supplies to the organizations that help our nation's most vulnerable citizens.

Cooking Up Better Lives seeks to improve the functionality, efficiency and value of community-based non-profit programs. It is the vision that shelters, homes, hospitals and other community-based entities in need of foodservice products or funds, can have the opportunity to receive and leverage contributions.

The bi-annual Better Lives Kitchen Makeover seeks to fill the wishlist of a selected non-profit organization. Wishlist items can include anything from flatware to walk-in coolers and even design, plumbing, warehousing and installation services.

Past recipients of the Better Lives Kitchen Makeover include:

- Creative Dreams: an after-school art and tutoring program for financially disadvantaged middle and high school students.
- Kingsley House: an organization which supports vulnerable children, disabled adults and seniors.
- House in the Woods: an outdoor retreat center that honors the sacrifices of veterans and their families, and assists them in their journey towards healing after loss.
- Delancey Street Foundation: a vocational school and self-help organization for substance abusers, ex-convicts, homeless and others who have hit rock bottom.



## 2019 Better Lives Kitchen Makeover: The Center

Cooking Up Better Lives' 2019 recipient, The Center, is an addiction recovery center located in Palos Park, Illinois. Their newly renovated kitchen is expected to serve over 33,000 meals per year. More than \$270,000 in donations was raised, including \$90,000 of foodservice equipment from our buying group's dealer and vendor partners.

### About The Center

The Center's mission is to give people of all faiths, backgrounds, and ages the space to dream, grow and become fully alive - physically, mentally, emotionally and spiritually. Programs and activities include an on-site substance-abuse recovery program, as well as prayer services, preschool through second-grade classes, farm tours and agricultural education, summer camp, and a full-ranging art program.

Thank you to our  
vendor partners:

Story featured in:





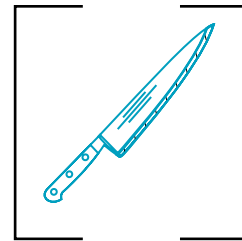

## How to Use a Sharpening Steel

Hold the steel vertically on a non-slip surface with your left hand and the knife in your right hand (the opposite applies for left-handed individuals.) As you move the blade from the bolster at a 20° angle from one side to the other, be sure to use light pressure and an arching motion, moving the arm and not the wrist. Some knives with the elite edge require the use of only fine-cut or smooth steels at a 15° angle. It is recommended that you use a steel that is longer than the blade of your knife. Depending upon the frequency and use of a knife, the edge will become dull

with its edge turning either to the right or to the left. A sharpening steel is critical for maintaining the best performance of your cutlery.

Using a sharpening stone to regrind your edge will eventually be necessary. With gentle pressure, pull the edge of the blade in a 15-20° angle across the stone from the bolster of the blade to its tip. Repeat the same procedure on the other side of the edge. Continue this process until the new edge is formed.

## How Knives Dull

Knives get dull because the edge folds, not, as popularly believed, because the edge wears away and gets blunt.

- There's no such thing as a "never-needs-sharpening" knife. So-called "never-needs-sharpening" knives are serrated. Serrated knives DO get dull. The tips of the serrations fold.

To delay dulling a sharp edge must have two main characteristics:

- **SYMMETRICAL:** A perfectly straight, symmetrical edge does not tend to lean in one direction or the other and thus does not fold as easily.
- **ARCH-SHAPED:** An edge with more metal behind it resists folding longer than a thin, weak "V"-shaped or hollow-ground edge.

## Sharpening Options

- Sharpening steels (and other devices which include rods) straighten the edge vs. actually resharpening it (creating a fresh, new edge). They take skill and effort to use. The unfolded edge is still weak and will immediately start to fold again. Eventually the edge is too weak to strengthen and the knife must be completely resharpened.
- Manual sharpeners with washers/discs lack reliable angle control and sharpen by skiving off pieces of the edge.
- Sharpening stones resharpen the edge. They take uncommon skill to hold the correct sharpening angles. It takes time and effort to use a stone.
- Sharpening services resharpen the edge. Many use inexpensive grinding wheels that overheat (detemper) knife edges and take off too much metal. Excess heat weakens the blade so it does not sharpen as well or stay sharp as long. Some professional services are more skilled than others.
- Electric sharpeners resharpen the edge. They sharpen safely and effectively and put stronger, longer-lasting arch-shaped edge on the knife.

## Different Blade Shapes

For different cutting tasks different blade shapes and edges are recommended. The differences are:

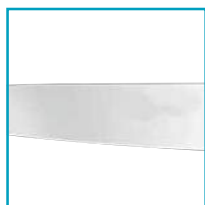

### Straight Edge

Allows a smooth and clean cut. When carving no fibres are torn out of the meat. This edge can be used for firm and soft food like meat, vegetables and fruit.

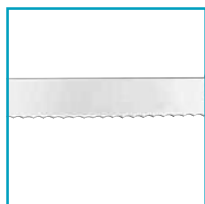

### Serrated Edge

The wavy or serrated edge allows an easy cut through crusty food like a traditional roast and crispy bread.



### Hollow Edge

When cutting, an air pocket is created between the hollow edge and the slice. This prevents food from sticking to the blade and allows for finer slices.



**Garnishing Knife** – Create crinkle-cut french fries, decorative garnishes and crudities, even eye-catching butter paddies.

**Paring Knife** – The knife used most frequently. Cuts, peels and dices fruits, vegetables, cheese and meats.

**Boning Knife** – Deboning chicken or ham, trimming fat and sinews. The tapered, pointed blade is a necessity for working closely around joints.

**Utility Knife** – Excellent for food preparation or almost any kitchen chore from cutting vegetables and meats to halving sandwiches.

**Chef's Knife** – (Also known as Cook's Knife or French Knife). It is the most essential of all knives used in the kitchen. Used for all kinds of heavy-duty cutting, as well as chopping, dicing and mincing of virtually every kind of food. Perfectly balanced, an extension of your hand.

**Carving Knife** – Ideal for ham and large cuts of meat and for breaking down larger fruits and vegetables.

**Bread Knife** – Slices breads, delicate fruits and vegetables. Cuts through hard crust for uniform slicing.

**Fillet Knife** – Filleting delicate fish or preparing carpaccio – it's easier with this extra thin, flexible blade.

**Steel** – Realigns the knife edge. Should be used frequently to maintain sharpness.

**Fork** – The perfect complement to any carving or slicing knife. Provides a secure hold, especially on the tail end of a joint of meat.

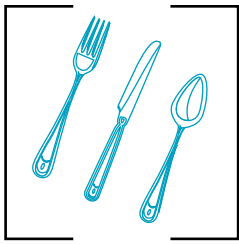

# TABLE SETTING GUIDE

Six of the Most Commonly Used Table Settings

View Dinnerware on pages 202, 219-227, 300, 301, 303 & 304

Drinkware on pages 234-240, 302 & 303

Flatware on pages 227-233

## China

Breakfast	Two Bread & Butter Plates, Cup, Saucer
Lunch	Bread & Butter Plate, Luncheon Plate
Dinner	Bread & Butter Plate, Salad Plate, Dinner Plate
Formal Dinner	Bread & Butter Plate, Two Salad Plates, Service Plate, Cup, Saucer
European	Bread & Butter Plate, Salad Plate, Service Plate
Banquet/Brunch	Bread & Butter Plate, Salad Plate, Dinner Plate, Cup, Saucer

## Glassware

Breakfast	Water Glass, Juice Glass
Lunch	Water Glass, Wine
Dinner	Water Goblet, Wine
Formal Dinner	Water Goblet, Champagne Flute, Wine
European	Water Goblet, Champagne Flute, Two Wines
Banquet/Brunch	Water Glass or Water Goblet, Wine

## Flatware\*

Breakfast	Dinner Fork, Dinner Knife, Teaspoon
Lunch	Salad Fork, Dinner Fork, Dessert or Dinner Knife, Teaspoon
Dinner	Salad Fork, Dinner Fork, Dinner Knife, Teaspoon, Butter Knife
Formal Dinner	Salad Fork, Dinner Fork, Dinner Knife, Oval Bowl/Dessert/Dinner Spoon, Teaspoon, Butter Knife
European	Dinner Fork (European size), Dinner Fork, Dinner Knife (European size), Dessert Knife, Oval Bowl/Dessert/Dinner Spoon, Small Teaspoon (European size), Butter Knife, Fish Knife, Fish Fork
Banquet/Brunch	Salad Fork, Dinner Fork, Dinner Knife, Teaspoon

\*All items U.S. size unless specified otherwise.

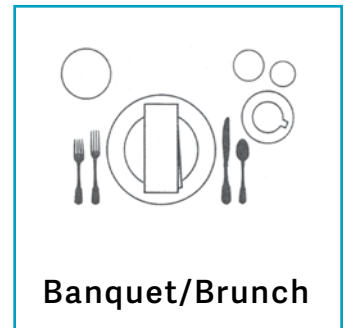
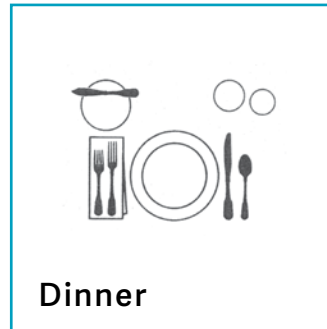
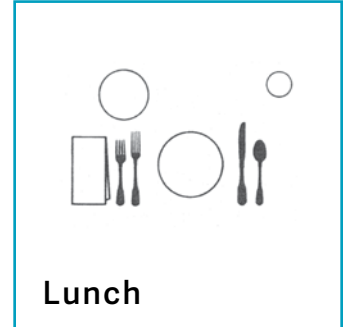
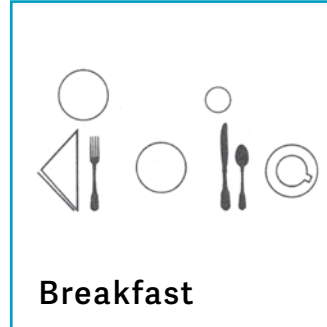

## Flatware Pieces

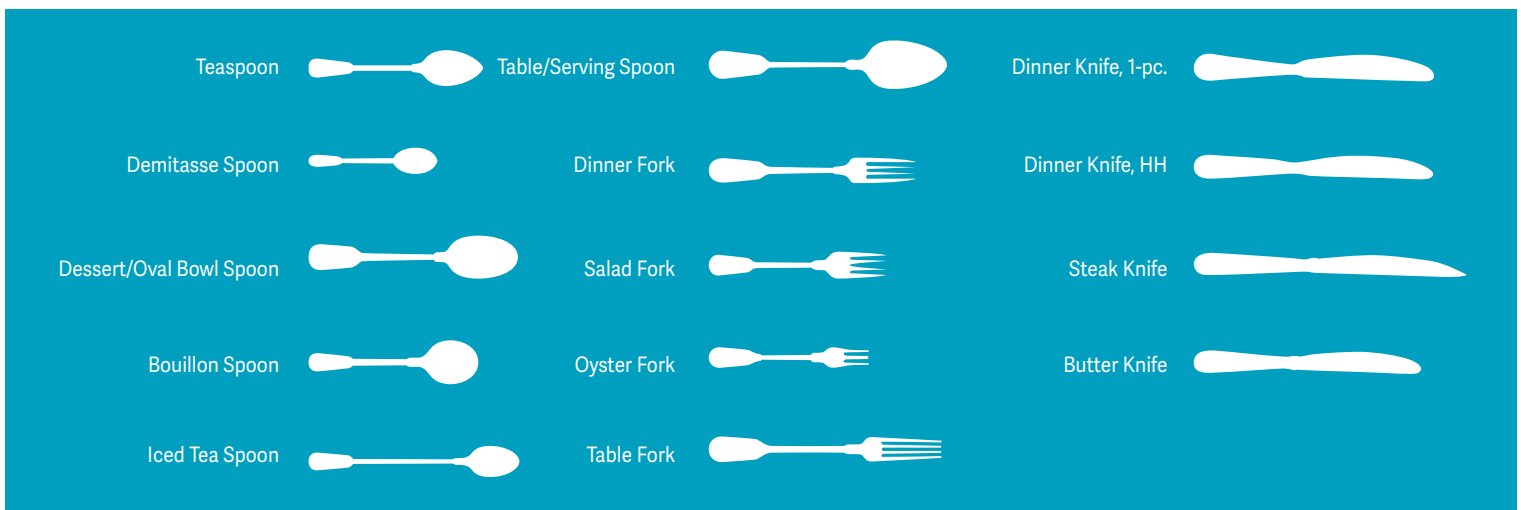

# COOKWARE GUIDE

Materials, Types,  
and Their Uses

View Cookware on  
pages 137-140, 269 & 270

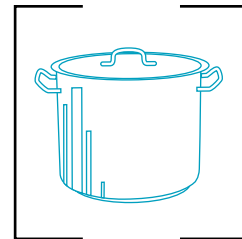

## Aluminum

Aluminum is the most common material for cookware, as it is an excellent conductor of heat and is inexpensive compared to stainless steel or copper cookware. Although features such as the lid, handle and finish are important, thickness is the key element of quality. The thicker the pan, the better the heat dispersion. Aluminum is reactive and the soft metal dents and scratches easily. To compensate for these drawbacks, manufacturers have developed anodized aluminum cookware, in which the pans undergo electrolytic processing that makes the outer surface both harder and less reactive.

## Stainless Steel

Stainless steel quality is determined by nickel content. In general, the greater the nickel content, the better the quality, as nickel allows a brighter, more durable rust resistant luster. Although durable, non-reactive and beautiful, stainless steel is a poor heat conductor. Inexpensive cookware is prone to hot spots and warping over high heat. Stainless steel is most effective with an aluminum or copper disc added to the bottom.

## Traditional vs. Nonstick

There are advantages to both traditional and nonstick pans. The latter are easy to clean and require very little cooking fat, while traditional surfaces excel at developing fond, those crusty, stuck-on bits of food that add deep flavor and color to pan sauces. Light-colored interior finishes make it easy to watch for signs of burnt drippings.



### Stock Pots

Excellent for preparing large quantities of seasoned liquids, pastas, soups, bulk vegetables and seafood. Ideal for slow simmering.



### Fry Pans

Fry small tender foods such as eggs, fish, chicken pieces, pork chops and soft vegetables. Shallow sides for easy stirring and sliding food out of the pan.



### Braziers

Wide heating surface allows the cooking of meats and vegetables in limited amounts of liquid. Ideal for long, slow cooking which allows the liquid to add juices and flavor.



### Sauté Pans

Straight-sided pan is ideal for stir-frying beef, chicken, pork, shrimp and vegetables. Browning vegetables, quick stewing and poaching are other uses for this heavy frying pan.



### Sauce Pots

Wide bottom area for maximum heat conduction. Ideal for slow cooking stews, sauces, soups, casseroles and roasts while reducing the content.



### Sauce Pans

Excellent for cooking soup, vegetables, sauces and for simmering and boiling foods in liquid.

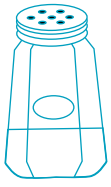

# DINING PURCHASING GUIDE

## Basic Product Requirements for Dining by Venue

View Dinnerware on pages 202, 219-227, 300, 301, 303 & 304

Drinkware on pages 234-240, 302 & 303

Flatware on pages 227-233

### Dinnerware

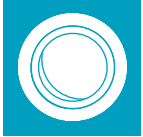

	FINE DINING 60-80 SEAT	RESTAURANT 100 SEAT	DELI 75 SEAT	PIZZA 75 SEAT	CAFETERIA 200 SEAT	BUFFET 200 SEAT
Service Plate	___ 10 dz					
Dinner Plate	___ 20 dz	___ 20 dz		___ 12 dz	___ 25 dz	___ 40 dz
Salad Plate	___ 20 dz	___ 20 dz	___ 10 dz	___ 10 dz		
Platter		___ 10 dz	___ 12 dz		___ 12 dz	___ 7 dz
Soup/Salad Bowl	___ 9 dz	___ 9 dz	___ 9 dz		___ 10 dz	___ 18 dz
Bouillon	___ 3 dz	___ 10 dz	___ 6 dz	___ 6 dz	___ 5 dz	___ 25 dz
Fruit Bowl	___ 20 dz	___ 20 dz			___ 38 dz	___ 38 dz
Coffee Cup	___ 10 dz	___ 8 dz	___ 8 dz	___ 8 dz	___ 18 dz	___ 18 dz
Saucer	___ 10 dz	___ 8 dz	___ 8 dz	___ 8 dz	___ 18 dz	
18 oz Nappie		___ 8 dz	___ 8 dz		___ 5 dz	
Bread & Butter	___ 20 dz	___ 20 dz				
5 oz Rarebit	___ 10 dz	___ 10 dz				
8 oz Rarebit	___ 5 dz				___ 4 dz	
12 oz Rarebit	___ 5 dz	___ 5 dz			___ 4 dz	
Escargot Plate	___ 3 dz					
12 oz Casserole	___ 3 dz					
4½ oz Baking Shell	___ 3 dz					
3 oz Sauce Dish	___ 3 dz					
2½ oz Ramekin	___ 3 dz					
5 oz Ramekin	___ 3 dz				___ 5 dz	

### Glassware



5 oz Juice		___ 12 dz	___ 12 dz	___ 12 dz	___ 12 dz	
10 oz Water	___ 20 dz	___ 20 dz	___ 20 dz	___ 20 dz	___ 25 dz	___ 30 dz
14 oz Large Beverage	___ 15 dz	___ 15 dz	___ 15 dz	___ 15 dz	___ 25 dz	___ 30 dz
4½ oz Sherbet	___ 6 dz	___ 6 dz	___ 6 dz	___ 6 dz	___ 6 dz	

### Flatware



Teaspoon	___ 30 dz	___ 30 dz	___ 12 dz	___ 12 dz	___ 65 dz	___ 40 dz
Dessert/Oval Bowl Spoon	___ 15 dz	___ 15 dz			___ 40 dz	___ 40 dz
Iced Tea Spoon	___ 15 dz	___ 15 dz	___ 12 dz	___ 15 dz	___ 21 dz	___ 21 dz
Bouillon Spoon	___ 15 dz	___ 15 dz	___ 8 dz	___ 8 dz	___ 34 dz	___ 34 dz
Dinner Fork	___ 30 dz	___ 30 dz	___ 12 dz	___ 12 dz	___ 100 dz	___ 60 dz
Salad Fork	___ 15 dz	___ 15 dz				
Dinner Knife	___ 20 dz	___ 20 dz	___ 8 dz	___ 8 dz	___ 40 dz	___ 40 dz
A.D. Coffee Spoon	___ 5 dz					
Oyster Fork	___ 8 dz					
Spreader	___ 12 dz					

# BAR PURCHASING GUIDE

Basic Product Requirements  
for Bar Service

View Bar Supplies on  
pages 185-195 & 288-290



Amounts Based on 100 People—Calculate Your Needs Here	Hotels/Cocktail Lounges	Restaurants	Caterers
Champagnes 4½ - 6 oz	3 dz	3 dz	9 dz
Cocktails 2½ - 5 oz	9 dz	6 dz	12 dz
All Purpose Wine	6 dz	6 dz	9 dz
White Wine 6½ - 9 oz	3 dz	-	-
Red Wine 6½ - 16 oz	3 dz	-	-
Sherries 2 - 4½ oz	3 dz	-	9 dz
Whiskey Sours	3 dz	-	-
Brandy/Cordials ¾ - 2 oz	3 dz	-	6 dz
Whiskey/Shot ¾ - 3 oz	3 dz	3 dz	-
Old Fashioned	9 dz	12 dz	
Rocks 6 - 9 oz	9 dz	6 dz	12 dz
Collins 9 - 12 oz	3 dz	3 dz	-
Hi Balls 7 - 10 oz	9 dz	6 dz	12 dz
Beer Glasses	3 dz	6 dz	-
Decanters 2½- 6 oz	3 dz	3 dz	-
Side Water Pitchers 8 - 24 oz	1 dz	-	6 ea
Stirrers	1-5,000 ea	1-5,000 ea	10,000 ea
Wine Buckets/Stands	4 ea	2 ea	10 ea
Ice Buckets	6-12 ea	6 ea	10 ea
Liquor Pourers	3-6 dz	2-4 dz	-
Bar Mixer	2 ea	1 ea	6 ea
Ice Scoop	2 ea	1 ea	1 ea
Cocktail Shakers Complete	6 ea	3 ea	6 ea
Jiggers, Metal - ½ - 2 oz	2-3 ea	1-2 ea	4 ea
Cutting Board	2 ea	1 ea	1 ea
Sponges	12 ea	6 ea	6 ea
Lemon Peeler	1 ea	1 ea	1 ea
Bar Strainer	2-3 ea	1 ea	2 ea
Ice Pick, Shaver	2 ea	1 ea	2 ea
Bar Spoons	6 ea	2 ea	2 ea
Muddler	2 ea	1 ea	-
Towel Holder	3 ea	1 ea	-
Bar Caddy	3 ea	1 ea	2 ea
Cork Removers	4-6 ea	2 ea	10 ea
Paring Knife	3 ea	1 ea	2 ea
Coasters	50,000 ea	25,000 ea	100,000 ea
Beverage Napkins	50,000 ea	25,000 ea	100,000 ea
Picks	10,000 ea	5,000 ea	-
Cocktail Straws	5,000 ea	2,000 ea	-

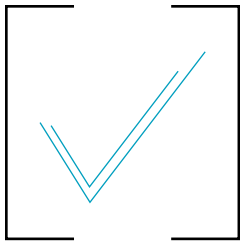

# PURCHASING GUIDE

A Quick Checklist to  
Get You Started

## Tabletop Items

- \_\_\_\_\_ Bread Basket
- \_\_\_\_\_ Candles
- \_\_\_\_\_ Coffee Servers
- \_\_\_\_\_ Lighting
- \_\_\_\_\_ Linen - Napkin
- \_\_\_\_\_ Linen - Tablecloth
- \_\_\_\_\_ Menu Covers
- \_\_\_\_\_ Oil & Vinegar Jar
- \_\_\_\_\_ Placements
- \_\_\_\_\_ Salt & Pepper
- \_\_\_\_\_ Salt & Pepper Holder
- \_\_\_\_\_ Sugar & Creamer
- \_\_\_\_\_ Syrup Dispenser
- \_\_\_\_\_ Vase

## Table Service Items

- \_\_\_\_\_ Bus Cart
- \_\_\_\_\_ Coffee Servers
- \_\_\_\_\_ Condiment Servers
- \_\_\_\_\_ Crepe Pan
- \_\_\_\_\_ High Chairs
- \_\_\_\_\_ Pastry Cart
- \_\_\_\_\_ Pepper Mill
- \_\_\_\_\_ Serving Cart
- \_\_\_\_\_ Serving Fork/Spoon
- \_\_\_\_\_ Tray (Dining Room)
- \_\_\_\_\_ Tray (Lounge)
- \_\_\_\_\_ Tray Stands
- \_\_\_\_\_ Wine Bucket
- \_\_\_\_\_ Wine Stand

## Salad Bar Items

- \_\_\_\_\_ Bread Knife
- \_\_\_\_\_ Cutting Board
- \_\_\_\_\_ Dressing Crocks
- \_\_\_\_\_ Ladles
- \_\_\_\_\_ Pepper Mill
- \_\_\_\_\_ Salad Bowl
- \_\_\_\_\_ Salad Plate/Bowl
- \_\_\_\_\_ Sneeze Guard

## Bar

- \_\_\_\_\_ Bar Spoon
- \_\_\_\_\_ Bar Stirrers
- \_\_\_\_\_ Blenders
- \_\_\_\_\_ Can Opener
- \_\_\_\_\_ Cocktail Strainer
- \_\_\_\_\_ Condiment Trays
- \_\_\_\_\_ Corkscrew
- \_\_\_\_\_ Cutting Board
- \_\_\_\_\_ Floor Matting

- \_\_\_\_\_ Glass Shakers
- \_\_\_\_\_ Glass Washer
- \_\_\_\_\_ Ice Pick
- \_\_\_\_\_ Liquor Pourers
- \_\_\_\_\_ Overflow Pipe
- \_\_\_\_\_ Plastic Shakers
- \_\_\_\_\_ Salt & Pepper Shakers
- \_\_\_\_\_ Shelf Matting
- \_\_\_\_\_ Speed Rail
- \_\_\_\_\_ Store 'n Pour Dispenser
- \_\_\_\_\_ Waitress Station
- \_\_\_\_\_ Waste Basket
- \_\_\_\_\_ Wine Rack
- \_\_\_\_\_ Wooden Muddler

## China

- \_\_\_\_\_ Au Gratin Dish
- \_\_\_\_\_ Baker
- \_\_\_\_\_ Bouillon
- \_\_\_\_\_ Casserole
- \_\_\_\_\_ Creamers
- \_\_\_\_\_ Cup
- \_\_\_\_\_ Dessert Plate
- \_\_\_\_\_ Dinner Plate
- \_\_\_\_\_ Espresso Cup & Saucer
- \_\_\_\_\_ Fruit Bowl
- \_\_\_\_\_ Grapefruit Bowl
- \_\_\_\_\_ Lunch Plate
- \_\_\_\_\_ Onion Soup Bowl
- \_\_\_\_\_ Platter
- \_\_\_\_\_ Ramekin
- \_\_\_\_\_ Salad Bowl
- \_\_\_\_\_ Saucer
- \_\_\_\_\_ Shirred Egg Dish
- \_\_\_\_\_ Side Order Plate
- \_\_\_\_\_ Sizzle Platter
- \_\_\_\_\_ Tea Cup
- \_\_\_\_\_ Welsh Rarebit

## Glassware

- \_\_\_\_\_ Beer Glass
- \_\_\_\_\_ Beer Mugs
- \_\_\_\_\_ Brandy Snifter
- \_\_\_\_\_ Champagne
- \_\_\_\_\_ Cocktail
- \_\_\_\_\_ Collins
- \_\_\_\_\_ Cordials
- \_\_\_\_\_ Decanters
- \_\_\_\_\_ Hi-Ball
- \_\_\_\_\_ Iced Tea
- \_\_\_\_\_ Juice
- \_\_\_\_\_ Milk
- \_\_\_\_\_ Pitchers
- \_\_\_\_\_ Rocks

- \_\_\_\_\_ Sherbet
- \_\_\_\_\_ Sherry
- \_\_\_\_\_ Specialty Stemware
- \_\_\_\_\_ Water Goblet
- \_\_\_\_\_ Whiskey Glass
- \_\_\_\_\_ Whiskey Sour
- \_\_\_\_\_ Wine

## Flatware

- \_\_\_\_\_ Bouillon Spoon
- \_\_\_\_\_ Bread & Butter Knife
- \_\_\_\_\_ Dessert Spoon
- \_\_\_\_\_ Dinner Fork
- \_\_\_\_\_ Dinner Knife
- \_\_\_\_\_ Iced Tea Spoon
- \_\_\_\_\_ Oyster Fork
- \_\_\_\_\_ Salad Fork
- \_\_\_\_\_ Serving Fork
- \_\_\_\_\_ Serving Spoon
- \_\_\_\_\_ Steak Knife
- \_\_\_\_\_ Table Spoon
- \_\_\_\_\_ Teaspoon

## Service Area

- \_\_\_\_\_ Bread Knife
- \_\_\_\_\_ Bussing Carts
- \_\_\_\_\_ Butter Holders
- \_\_\_\_\_ Coffee Server
- \_\_\_\_\_ Coffee Warmer
- \_\_\_\_\_ Condiment Server
- \_\_\_\_\_ Cutting Board
- \_\_\_\_\_ Dust Pan
- \_\_\_\_\_ Food Warmer
- \_\_\_\_\_ Ice Buckets/Stands
- \_\_\_\_\_ Linen Storage Racks
- \_\_\_\_\_ Lobby Brooms
- \_\_\_\_\_ Vacuum
- \_\_\_\_\_ Water Station

## Signage

- \_\_\_\_\_ Emergency Lights
- \_\_\_\_\_ Exterior - Delivery
- \_\_\_\_\_ Exterior - Entrance
- \_\_\_\_\_ Interior - Directional
- \_\_\_\_\_ Interior - Exit
- \_\_\_\_\_ Interior - Menu
- \_\_\_\_\_ Interior - Restrooms
- \_\_\_\_\_ Interior - Wet Floor

## Entrance Area

- \_\_\_\_\_ Matting
- \_\_\_\_\_ Menu Board
- \_\_\_\_\_ Sand Urn

# PURCHASING GUIDE

A Quick Checklist to  
Get You Started

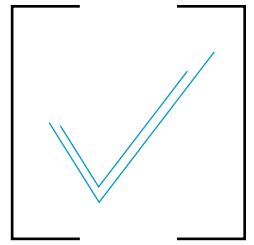

## Receiving Area

- \_\_\_\_\_ Box Openers
- \_\_\_\_\_ Door Matting
- \_\_\_\_\_ Hand Truck
- \_\_\_\_\_ Shelving
- \_\_\_\_\_ Signage
- \_\_\_\_\_ Trash Can

## Storage Area

- \_\_\_\_\_ Food Storage Boxes
- \_\_\_\_\_ Greens Keeper
- \_\_\_\_\_ Shelving
- \_\_\_\_\_ Thermometers
- \_\_\_\_\_ Transport Cart
- \_\_\_\_\_ Trash Containers

## Prep Area

- \_\_\_\_\_ Bakers Scale
- \_\_\_\_\_ Boning Knife
- \_\_\_\_\_ Butcher Knife
- \_\_\_\_\_ Can Opener
- \_\_\_\_\_ China Caps
- \_\_\_\_\_ Choppers
- \_\_\_\_\_ Cleaver Knife
- \_\_\_\_\_ Colanders
- \_\_\_\_\_ Cook's Knife
- \_\_\_\_\_ Cutting Boards
- \_\_\_\_\_ Food Storage Boxes
- \_\_\_\_\_ Funnels
- \_\_\_\_\_ Graters
- \_\_\_\_\_ Grinders
- \_\_\_\_\_ Ingredient Scoops
- \_\_\_\_\_ Kitchen Spoons
- \_\_\_\_\_ Ladles
- \_\_\_\_\_ Measures
- \_\_\_\_\_ Measuring Cups
- \_\_\_\_\_ Measuring Spoons
- \_\_\_\_\_ Meat Tenderizer
- \_\_\_\_\_ Mixing Bowls
- \_\_\_\_\_ Muffin Tins
- \_\_\_\_\_ Paddles
- \_\_\_\_\_ Paring Knife
- \_\_\_\_\_ Pastry Brushes
- \_\_\_\_\_ Portion Scale
- \_\_\_\_\_ Potato Masher
- \_\_\_\_\_ Potato Peeler
- \_\_\_\_\_ Roasting Pans
- \_\_\_\_\_ Salt & Pepper Dredge
- \_\_\_\_\_ Sauce Pans
- \_\_\_\_\_ Saute Pans
- \_\_\_\_\_ Scraper
- \_\_\_\_\_ Shears, Kitchen
- \_\_\_\_\_ Shears, Poultry

- \_\_\_\_\_ Sheet Pans
- \_\_\_\_\_ Sieve
- \_\_\_\_\_ Sifter
- \_\_\_\_\_ Skewers
- \_\_\_\_\_ Skimmers
- \_\_\_\_\_ Stock Pot Covers
- \_\_\_\_\_ Stock Pots
- \_\_\_\_\_ Strainers
- \_\_\_\_\_ Thermometers
- \_\_\_\_\_ Timers
- \_\_\_\_\_ Whips, French
- \_\_\_\_\_ Whips, Piano

## Bakery Area

- \_\_\_\_\_ Cutting Boards
- \_\_\_\_\_ Dough Cutters
- \_\_\_\_\_ Ingredient Bins
- \_\_\_\_\_ Ingredient Scoops
- \_\_\_\_\_ Marble Slab
- \_\_\_\_\_ Measuring Cups
- \_\_\_\_\_ Pastry Bags
- \_\_\_\_\_ Pastry Brushes
- \_\_\_\_\_ Pastry Tips
- \_\_\_\_\_ Pie Markers
- \_\_\_\_\_ Pie Plates
- \_\_\_\_\_ Roller Docker
- \_\_\_\_\_ Rolling Pins

## Warewashing Area

- \_\_\_\_\_ Anti-Slip Matting
- \_\_\_\_\_ Aprons
- \_\_\_\_\_ Clean Dish Storage
- \_\_\_\_\_ Cup Racks
- \_\_\_\_\_ Dishracks
- \_\_\_\_\_ Faucet
- \_\_\_\_\_ Flatware Racks
- \_\_\_\_\_ Floor Squeegee
- \_\_\_\_\_ Pre-Soak System
- \_\_\_\_\_ Rack Dollies
- \_\_\_\_\_ Scrap Block
- \_\_\_\_\_ Silverware Sorting System
- \_\_\_\_\_ Trash Containers
- \_\_\_\_\_ Tray Stand

## Kitchen Production Area

- \_\_\_\_\_ Aprons
- \_\_\_\_\_ Bains Marie
- \_\_\_\_\_ Braziers
- \_\_\_\_\_ Breeding Baskets
- \_\_\_\_\_ Floor Matting
- \_\_\_\_\_ Food Storage Boxes

- \_\_\_\_\_ Fryer Baskets
- \_\_\_\_\_ Fry Pans
- \_\_\_\_\_ Grill Stones/Screens
- \_\_\_\_\_ Hand Towels
- \_\_\_\_\_ Ladles
- \_\_\_\_\_ Oven Mitts
- \_\_\_\_\_ Picks/Steak Markers
- \_\_\_\_\_ Plastic Storage Containers
- \_\_\_\_\_ Pressure Cooker
- \_\_\_\_\_ Roast Beef Slicer
- \_\_\_\_\_ Salt & Pepper Dredges
- \_\_\_\_\_ Sauce Pans
- \_\_\_\_\_ Saute Pans
- \_\_\_\_\_ Scale, Portion
- \_\_\_\_\_ Scoops
- \_\_\_\_\_ Sharpening Steel
- \_\_\_\_\_ Spatula
- \_\_\_\_\_ Spice Storage
- \_\_\_\_\_ Spoons
- \_\_\_\_\_ Steam Table Inserts/Covers
- \_\_\_\_\_ Steam Table Pans
- \_\_\_\_\_ Stock Pots
- \_\_\_\_\_ Strainers
- \_\_\_\_\_ Thermometers
- \_\_\_\_\_ Timer
- \_\_\_\_\_ Tongs
- \_\_\_\_\_ Turner
- \_\_\_\_\_ Whips

## Buffet Service

- \_\_\_\_\_ Carving Stand
- \_\_\_\_\_ Chafing Dishes
- \_\_\_\_\_ Coffee Server
- \_\_\_\_\_ Crystalware Bowls
- \_\_\_\_\_ Crystalware Trays
- \_\_\_\_\_ Dessert Merchandiser
- \_\_\_\_\_ Foodwarmers (back-up)
- \_\_\_\_\_ Fuel Cans
- \_\_\_\_\_ Ice Molds
- \_\_\_\_\_ Serving Utensils
- \_\_\_\_\_ Table Skirts & Clips

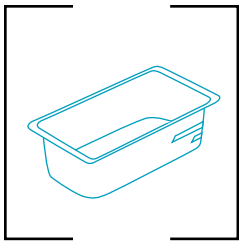

# HELPFUL MEASUREMENT GUIDES

Steam Table Pan Arrangements and Capacity Charts

View Steam Table Pans on page 136

Dishers on page 114

Ladles pages 196, 200 & 266

## Guide to Steam Table Pans

Complete flexibility for steam table service is available through a wide range of sectional pans that includes: Full Size, 2/3 Size, 1/2 Size, 1/2 Long Size, 1/3 Size, 1/4 Size, 1/6 Size and 1/9 Size. All are made to fit both 19 7/8" x 11 7/8" or 20" x 12" openings.

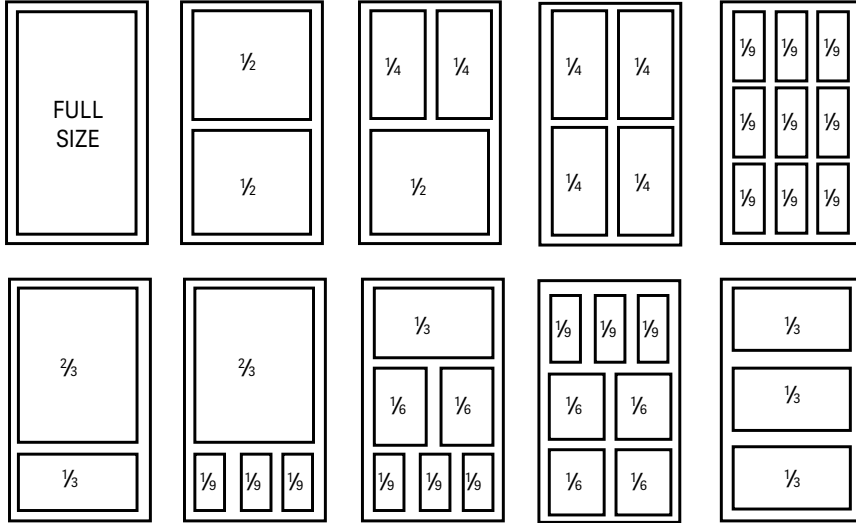

Size	Width (L to R)	Length (F to B)
Full	12"	20"
1/2	12"	10"
1/4	6"	10"
2/3	12"	13 1/3"
1/3	12"	6 2/3"
1/6	6"	6 2/3"
1/9	4"	6 2/3"

Standard depths are 2 1/2", 4" and 6". Adapter bars in 12" or 20" lengths are needed when your arrangement gives unsupported corners. A large variety of lid sizes and types are available.

## Disher Capacities

Color	Disher Size	Bowl Dia	Fluid Oz*	Wt Oz*	Patties/Lb†	Scoops/Gal‡	Equivalent
White	6	3"	4.66	4.86	3	16	2/3 Cup
Grey	8	2 3/4"	3.64	3.80	3 1/2	22	1/2 Cup
Ivory	10	2 5/8"	3.19	3.33	4	24	5/6 Cup
Green	12	2 1/2"	2.78	2.90	5	26	1/3 Cup
Blue	16	2 1/4"	2.07	2.16	6-8	35	1/4 Cup
Yellow	20	2 1/8"	1.77	1.84	9-10	42	3+ Tbsp
Red	24	2"	1.49	1.56	11-12	51	2 2/3 Tbsp
Black	30	1 3/4"	1.03	1.07	13-14	62	2+ Tbsp
Purple	40	1 1/2"	.68	.70	15-16	70	1 1/2 Tbsp

\* Water Capacity †Hamburger Patties ‡Ice Cream Scoop



## Soup-Sauce Ladles

Size	1 oz	2 oz	4 oz	6 oz	8 oz
Equivalent	1/8 cup	1/4 cup	1/2 cup	3/4 cup	1 cup



# HELPFUL MEASUREMENT GUIDES

Standard Weights, Measures and  
Equivalency Charts

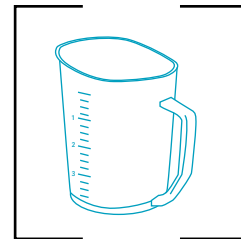

## Liquid Capacity

		LITER
1 gill	=	7.219 cu in = 0.1183
4 gills	=	1 pint = 28.2875 cu in = 0.4732
2 pt	=	1 quart = 57.75 cu in = 0.9463
4 qt	=	1 gallon = 231 cu in = 3.7853
31.5 gal	=	1 barrel liquid = 119.24
42 gal	=	1 barrel petrol = 158.98

## Dry Capacity

		LITER
1 pint	=	33.6 cu in = 0.5506
2 pt = 1 quart	=	67.2 cu in = 1.1012
8 qt = 1 peck	=	537.6 cu in = 8.8096
4 pk = 1 bushel	=	2150.4 cu in = 35.238
1 barrel	=	7056 cu in = 115.62

## Household Capacity

3 teaspoons	=	1 teaspoon	=	1/8 fl oz
16 tablespoons	=	1 tablespoon	=	1/2 fl oz
2 cups	=	1 cup	=	8 fl oz
2 pints	=	1 pint	=	16 fl oz
4 quarts	=	1 quart	=	32 fl oz
			=	128 fl oz

## Basic Liquid Equivalents

Dash	=	less than 1/8 teaspoon
3 teaspoons	=	1 tablespoon
4 tablespoons	=	1/4 cup
5 1/2 tablespoons	=	1/2 cup
8 tablespoons	=	1/2 cup
10 1/2 tablespoons	=	3/4 cup
12 tablespoons	=	3/4 cup
14 tablespoons	=	7/8 cup
16 tablespoons	=	1 cup
1 cup	=	1/2 pint (8 fl ounces)
2 cups	=	1 pint (16 fl ounces)
2 pints	=	1 qt (32 fl ounces)
4 qt	=	1 gallon (128 fl ounces)
16 oz	=	1 pound (dry weight)

## Avoirdupois Weight

1 grain	=	0.0648 g
27.343 gr	=	1 dram = 1.7718 g
16 dr	=	1 ounce = 28.3495 g
16 oz	=	1 pound = 453.5924 g
100 lb	=	1 hundredweight = 45.3592 kg
2000 lb	=	1 short ton = 907.18 kg

## Recipe Abbreviations

tsp	teaspoonful
TBSP	tablespoonful
c	cup
pt	pint
qt	quart
pk	peck
bu	bushel
oz	ounce or ounces
lb	pound or pounds
sq	square
min	minute or minutes
hr	hour or hours
mod.	moderate
dz	dozen
E.P.	edible portion
A.P.	as purchased



## Ice Cream Scoops

Size	Equivalent	Scoops per Qt
No. 6	3/8 cup	3 to 5
No. 8	1/2 cup	5 to 7
No. 10	5/8 cup	7 to 8
No. 12	3/4 cup	7 to 10
No. 16	1/2 cup	10 to 13
No. 20	3+ TBSP	14 to 17
No. 24	2 1/2 TBSP	17 to 20
No. 30	2+ TBSP	21 to 25
No. 40	1 1/2 TBSP	25 to 28

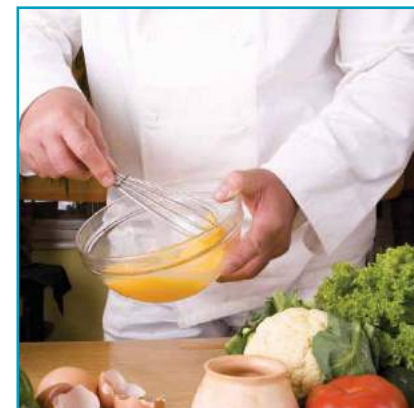

## Boiling Temperatures of Water at Various Altitudes

Sea Level	212.0°F	100.0°C
2,000 ft	208.4°F	98.4°C
5,000 ft	203.0°F	95.0°C
7,500 ft	198.4°F	92.4°C

## Oven Temperatures

Slow	250° - 300°F
Slow-Moderate	325°F
Moderate	350° - 375°F
Moderately Hot	400°F
Hot	425° - 450°F

## Counting

1 dozen	=	12 units
12 dozen	=	1 gross = 144 units
12 gr	=	1 great gross = 1728 units

## To Substitute for Shell Eggs

Shell Eggs	Whole Egg Blend	Plus Water
1	1/8 cup	1/8 cup
2	1/4 cup	1/4 cup
3	3/8 cup	3/8 cup
4	1/2 cup	1/2 cup
5	5/8 cup	5/8 cup
6	1 cup	1 cup
7	1 1/8 cups	1 1/8 cups
8	1 1/4 cups	1 1/4 cups
9	1 1/2 cups	1 1/2 cups
10	1 5/8 cups	1 5/8 cups

## To Substitute for Liquid Eggs

Liquid Egg Equivalent	Whole	Egg Blends	Plus	Water
Lb	Lb	Oz	Lb	Lb
1	—	4	—	12
2	—	8	1	8
3	—	12	2	4
4	1	0	3	0
5	1	4	3	12
6	1	8	4	8
7	1	12	5	4
8	2	0	6	0
9	2	4	6	12
10	2	8	7	8

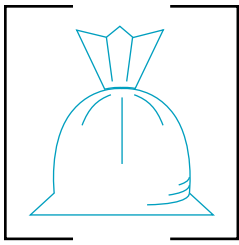

# CAN LINER GUIDE

Helpful Information About  
Gauges and Types

Contact a Sales Team Member for Pricing or to Schedule  
a Purchasing Review/Create a Program

## Why Gauge Isn't Always Important

Film thickness is no longer a satisfactory standard for judging overall strength. The development of improved LLDPE resin in the liner industry has changed the standard method for selecting can liners. Manufacturers can produce thinner, lighter trash bags that are stronger and more durable than the thicker bags previously made from low density resin. This is why gauge is no longer an effective way to determine liner strength. Instead of stating actual thickness, many liners are now simply described as "Light", "Medium", "Heavy", and "Extra Heavy".

Each manufacturer has its own blend formulations, so the proportions of the materials used vary from one producer to another. The best way to determine the correct liner is to test some suggested samples.

## Types of Bag Seals



### Star Seal (or X-Seal)

This unique design eliminates gaps along the seal where leaks can occur.

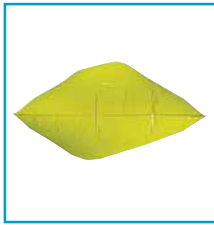

### Flat Seal

These bags are generally leak-proof, but are very clumsy to handle.



### Gusseted Seal

A flat style bag with both sides tucked in to form gussets.

## Definitions

**Resin** - The basic raw material from which can liners are made. There are 3 types of resins: Low Density, Linear Low Density and High Density Polyethylene.

**Linear Low Density Polyethylene** - This resin is highly puncture and tear resistant. These properties make this the best choice for applications where additional strength and stretch are required. Works well for waste with sharp or jagged edges.

**High Density Polyethylene** - Liners made from this resin are generally available in lower gauges, and are more temperature resistant.

**Low Density Polyethylene** - An older resin still used mainly in lower end utility liners. It has largely been replaced by Linear Low Density Polyethylene.

**Post Consumer and Post-Industrial Polyethylene** - This is made from recycled post-consumer plastics such as milk jugs and industrial scraps. These are reprocessed and blended with other types of resins to produce new high quality liners.

**Gauge** - A term used to describe the thickness of a liner. Low density liners are measured in mils, while High Density liners are generally measured in microns.

**Mil** - Measurement based on one hundred thousandths of an inch (.000). For example, a .55 mil bag would be 55 thousandths of an inch thick. Common low density liners range from .37 to 1.8 mil in thickness.

**Micron** - Based on thousandth of a Millimeter (.000000). High Density liners usually range from 6 to 22 microns in thickness.

General Industry Strength Rating	Linear Low Density Mil Thickness Range	Old Low Density Strength Rating
Regular	.35 to .50	1.25
Medium	.45 to .75	1.5
Heavy	.60 to 1.0	2.0
Heavy Plus	.74 to 1.3	2.5
Extra Heavy	.90 to 1.5	3.0

## Advantages of High Density Can Liners

1. HMW/HD liners are about 3x stronger and more durable than ordinary polyethylene liners of the same thickness
2. They can be made about one-third the thickness of ordinary low density polyethylene liners, so they require only about one-third the ordinary shipping, storage and warehousing cost
3. Substantial cost savings per liner
4. When they are properly made, HMW/HD liners will rarely "zipper" if punctured
5. Extremely wide range of temperature resistance from -40° to 212°F
6. USDA and FDA approved (natural-colored liners)

### Suggested applications:

- Cans without rough edges
- Paper
- Disposable dinnerware
- Food
- Dirt or grass
- Rags/cloth items
- Smooth heavy object
- Great for office waste baskets

## Advantages of Linear Low Density Can Liners

1. Maximum puncture and stretch resistance
2. Multi-purpose applications
3. Most prevalent type of film used in the industry today
4. Manufactured in a wide variety of colors
5. Compared to traditional low density film, linear low can be run at a lighter gauge with equal strength

### Suggested applications:

- Stick & rough yard trimmings, small rocks
- Metal w/sharp edges
- Nails & bolts
- Objects w/rough corners or protrusions
- Disposable flatware
- Abusive transport conditions
- Food w/rough edges (like crab legs)

# BRUSH TYPE GUIDE

Choosing the Best Brush for Your Specific Needs

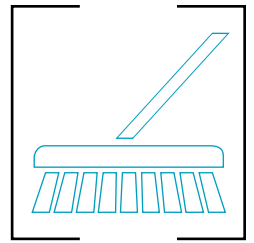

## Synthetic Bristles



### Nylon

Excellent abrasion resistance, shear/break strength, and bristle bend recovery. Very good chemical resistance and sustains temperatures up to 350°F. Best choice for abrasive, rough use.



### Polyester

Excellent chemical resistance, ultra violet light resistance, and bristle bend recovery. Very good abrasion resistance, and tear/break strength. Sustains temperatures up to 125°F. Best choice for all around use and for extreme exposure to cleaning chemicals.



### Polypropylene

Stiff and long-lasting bristles work well under any conditions. Resistant to chemicals, oil and water making them ideal for back-of-house cleaning.

## Natural Bristles



### Horsehair

A natural pointed tip, good shear/break resistance, and soft cleaning properties. Good durability and excellent blending properties make this an ideal choice for interior floor sweeps when blended with other fibers.



### Palmyra

Natural medium stiff fibers from India palms is an excellent choice for general floor sweeps. Provides good durability and bristle recovery.



### Tampico

Natural Tampico fiber from the Mexican agave plant is a soft to medium soft bristle with very good durability. Good choice for finer floor sweeps and general cleaning scrub brushes.



### Stainless Steel Wire

Rust proof, excellent chemical resistance, excellent bend recovery, provides a high degree of abrasion and wear resistance. Best foodservice choice for aggressive cleaning on grills and other heavily soiled foodservice equipment.



### Carbon Steel Wire

Provides a high degree of abrasion and wear resistance. Good bend recovery. Best choice for aggressive cleaning on grills and other heavily soiled equipment.



### Brass Wire

Rust resistant, provides a high degree of abrasion but is softer than stainless steel or carbon steel to prevent equipment damage. For use on ovens, griddles, and other metal equipment that is heavily soiled but cannot sustain heavy scratches.

# REFRIGERATION EQUIPMENT



MCF8723GR

## Glass Door Refrigerator Merchandisers

- Black steel exterior with stainless steel interior
- Lighted header panel
- LED interior lighting
- Dixell electronic controller
- Double pane glass doors
- Self-closing door with automatic stay open feature
- Recessed door handle
- Magnetic door gasket
- Environmentally friendly R290 refrigerant
- 2" casters
- 31½"d x 81½"h
- 2 year parts and labor warranty, 5 year compressor part warranty



	Width	Doors	Shelves	Cu Ft
MCF8722GR	27"	1	4	19.39
MCF8723GR	54¾"	2	8	43.8

## AdvantEDGE™ Bottom Mount Reach-Ins

- Stainless steel interior and exterior
- Air-cooled condensing unit
- Automatic condensate vaporizer & defrost
- Curved handle with recessed pocket
- Door open alarm
- Interior LED light
- Key locks
- Microprocessor with digital display
- Operating temperature range: 34° to 38°F
- Polyurethane insulation
- R290 refrigerant
- Vinyl coated shelves
- 4" diameter casters
- 33"d x 83¾"h
- 3 year parts and labor plus an additional 2 year warranty on compressor

	Length	Doors	Cu Ft	Shelves	HP
<b>Refrigerators</b>					
NLR23-S	27½"	1	23	4	¾
NLR49-S	55¼"	2	49	8	¾
NLR72-S	78"	3	72	12	¾
<b>Freezers</b>					
NLF23-S†	27½"	1	23	4	⅝
NLF49-S	55¼"	2	49	8	¾
NLF72-S	78"	3	72	12	1

†Not ENERGY STAR®

NLR49-S



## AdvantEDGE™ Glass Door Refrigerators

- Stainless steel interior and exterior
- Air-cooled condensing unit
- Automatic condensate vaporizer & defrost
- Door open alarm
- Interior LED lighting
- Microprocessor with digital display
- Operating temperature range: 34° to 38°F
- Polyurethane insulation
- Key locks
- R290 refrigerant
- Vinyl coated shelves
- 4" casters
- 32⅞"d x 83¾"h
- 3 year parts and labor plus an additional 2 year warranty on compressor

NLR49-G



	Length	Doors/Shelves	Cu Ft	HP
NLR23-G	27½"	1/4	23	¾
NLR49-G	55¼"	2/8	49	¾
NLR72-G	78"	3/12	70	¾

The full-length glass doors allow for easy viewing



## Super Deluxe Glass Door Merchandisers

- Self-cleaning condenser
- Energy conserving fan control
- Digital temperature control and monitor system
- Natural hydrocarbon refrigerant
- Refrigerators have double pane glass doors with Low-E glass
- Freezers have triple pane heated glass doors
- Interior LED lighting
- 2 color options available: White cabinet (W), Black cabinet with black color trim (B)
- 31 $\frac{1}{8}$ "d x 77"h (TGM-20SD-N6 is 26 $\frac{3}{8}$ "d, TGM-23SD is 30 $\frac{1}{4}$ "d)
- 115V
- 3 year parts and labor warranty with an additional 2 year warranty on compressor



TGM-47SDW-N

	Length	Doors	Shelves	Cu ft	HP
<b>Refrigerators - Hold 33° to 38°F</b>					
TGM-20SD-N6	27"	1	4	16.01	$\frac{1}{8}$
TGM-23SD-N6	27"	1	4	19.4	$\frac{1}{8}$
TGM-35SD-N	39 $\frac{1}{2}$ "	2	8	29.06	$\frac{1}{8}$
TGM-47SD-N	51 $\frac{1}{8}$ "	2	8	41.71	$\frac{1}{8}$
TGM-72SD-N	78"	3	12	67.98	$\frac{1}{2}$
<b>Freezers - Hold -10° to 5°F</b>					
TGF-23SD-N	27"	1	4	17.99	$\frac{3}{8}$
TGF-35SD-N	39 $\frac{1}{2}$ "	2	8	28.44	$\frac{3}{4}$
TGF-47SD-N	51 $\frac{1}{8}$ "	2	8	39	1
TGF-72SD-N	78"	3	12	60.43	$\frac{2}{3}$ x 2



## Glass Door Merchandisers

- Natural refrigerant
- Holds 33° to 38°F
- Positive seal self-closing doors
- Interior LED lighting
- No stoop bottom shelf
- Exterior - non-peel or chip black powder coated, cold rolled steel; durable and permanent
- Double pane thermal insulated glass
- Interior with NSF approved white aluminum interior liner and stainless steel floor
- Self-contained system, no plumbing required
- Bottom mount heavy-duty compressor
- Standard in Black - also available in White or Stainless Steel
- 115V
- 3 year parts and labor warranty with an additional 2 year warranty on compressor



	L x D x H	Doors	Shelves
GDM-23-HC-TSL01	27" x 29 $\frac{1}{8}$ " x 78 $\frac{1}{8}$ "	1	4
GDM-49-HC-TSL01†	54 $\frac{1}{8}$ " x 29 $\frac{1}{8}$ " x 78 $\frac{1}{8}$ "	2	8
GDM-72-HC-TSL01†	78 $\frac{1}{8}$ " x 29 $\frac{1}{8}$ " x 78 $\frac{1}{8}$ "	3	12

†Not CE



GDM-23-HC-TSL01

# REFRIGERATION EQUIPMENT

## Standard Line Refrigerators & Freezers

- Stainless steel front
- Aluminum end panels and interior
- LED interior lighting
- 5" casters
- Cylinder lock in each door
- 3" non-CFC polyurethane foam insulation
- Electronic controller with digital display and hi-low alarm
- 35 $\frac{3}{8}$ "d x 82 $\frac{1}{4}$ "h

### Additional Models Available

- Half Doors
- Pass-Thru
- Shallow Depth

Smooth, polished chrome workflow door handles

**Continental**  
Refrigerator



Refrigerators	Freezers	Length	Doors	Cu Ft	Shelves
1RN	1FN	26"	1	20	3
2RN	2FN	52"	2	48	6
3RN	3F	78"	3	70	9



2RN/2FN

## NOVA™ Top Mount Reach-Ins

- Stainless steel interior and exterior
- Air-cooled condensing unit
- Automatic condensate evaporation
- Automatic defrost
- Epoxy-coated shelves
- Field reversible doors with magnetic gaskets
- Hi/Lo audio and visual alarms
- Horizontal work flow handle with key locks
- Microprocessor with digital display
- Polyurethane insulation
- R-134 refrigerant (refrigerators); R-404A (freezers)
- Recessed interior LED light
- 4" diameter casters
- 35 $\frac{3}{8}$ "d x 81 $\frac{1}{2}$ "h
- DOE listed, CEC certified
- 3 year parts and labor plus an additional 2 year warranty on compressor

**NORLAKE**



	Length	Doors	Cu Ft	Shelves	HP
<b>Refrigerators</b>					
NR241	27 $\frac{1}{2}$ "	1	24	3	$\frac{1}{4}$
NR522	55"	2	52	6	$\frac{1}{3}$
NR803	82 $\frac{1}{2}$ "	3	80	9	$\frac{1}{2}$
<b>Freezers</b>					
NF241	27 $\frac{1}{2}$ "	1	24	3	$\frac{1}{2}$
NF522	55"	2	52	6	$\frac{3}{4}$
NF803	82 $\frac{1}{2}$ "	3	80	9	1



NR522



## T-Series Reach-In Refrigerators & Freezers

- Bottom mount compressor
- Stainless steel doors and front
- Clear coated aluminum interior with stainless steel floor
- No stoop lower shelf
- Factory engineered, self-contained, capillary tube system uses environmentally friendly R290 hydrocarbon refrigerant that has zero (0) ozone depletion potential (ODP) & three (3) global warming potential (GWP)
- Refrigerators hold 33° to 38°F, freezers hold -10°F
- Adjustable, heavy-duty PVC coated wire shelves
- Foamed-in-place using Ecomate, a high density polyurethane insulation
- Exterior temperature display
- 4" casters standard, legs available
- 29½" d x 78¾" h
- 3 year parts and labor with an additional 2 year warranty on compressor



	Length	Doors	Shelves	HP
<b>Refrigerators</b>				
T-23-HC†*	27"	1	3	¼
T-49-HC*	54½"	2	6	½
T-72-HC	78½"	3	9	¾
<b>Freezers</b>				
T-23F-HC†*	27"	1	3	½
T-49F-HC*	54½"	2	6	1
T-72F-HC	78½"	3	9	¾

†CE \*ENERGY STAR



## Spec Series® Reach-In Refrigerators & Freezers

- Stainless steel door with matching aluminum sides
- Interior features aluminum side walls & back and stainless steel floor & ceiling
- 3 heavy-duty, PVC-coated wire shelves per section
- HC models feature the new environmentally friendly R290 hydrocarbon refrigerant that has zero (0) ozone depletion potential (ODP) & three (3) global warming potential (GWP)
- High capacity, factory balanced refrigeration system maintains cabinet temperatures of 33° to 38°F for the best in food preservation
- Entire cabinet structure and solid door are foamed-in-place using Ecomate, a high density, polyurethane insulation that has zero ozone depletion potential (ODP) and zero global warming potential (GWP)
- Top-mounted refrigeration system with evaporator positioned out of food zone to maximize capacity
- Positive seal self-closing doors with 120° stay open feature
- Exterior digital temperature display
- 33¾" d x 77¾" h
- 3 year parts and labor with an additional 2 year warranty on compressor



	Length	Doors	Shelves	HP
<b>Refrigerators</b>				
STG1R-1S-HC*	27½"	1	3	¼
STG2R-2S-HC*	52½"	2	6	½
<b>Freezers</b>				
STG1F-1S-HC	27½"	1	3	½
STG2F-2S-HC	52½"	2	6	1¼

\*ENERGY STAR

# REFRIGERATION EQUIPMENT



USRF-2D



USRF-1D/19



## U-Star Bottom Mount Reach-Ins

- Stainless steel exterior and interior (narrow depth models have painted aluminum interior)
- Precise digital controller with LED display
- Recessed door handles
- 6" casters (two with brakes)
- Automatic defrosting
- 82½" h
- 1 year parts and labor, 5 year compressor warranty

### Standard Depth

Refrigerators	L x D	Doors	Shelves	HP
USRF-1D	29" x 32"	1	3	⅓
USRF-2D	54" x 32"	2	6	½
Freezers				
USFZ-1D	29" x 32"	1	3	½
USFZ-2D	54" x 32"	2	6	1
Narrow Depth				
USRF-1D/19	29" x 25"	1	3	¼
Freezer				
USFZ-1D/19	29" x 25"	1	3	½

## Super Deluxe Reach-Ins

- Maintenance free, self-cleaning condenser
- Digital temperature control system
- Hydrocarbon refrigerant
- High quality stainless steel exterior, interior and shelves
- Door pressure release device for easy, instant door opening
- 4" swivel casters
- 30⅞"d x 78¼"h
- 3 year parts and labor warranty and additional 2 year compressor warranty

	Length	Doors	Cu Ft	Shelves	HP
Refrigerators - Hold 33° to 38°F					
TSR-23SD-N6	27"	1	19.3	3	⅛
TSR-49SD-N6	54⅜"	2	42.69	6	⅓
TSR-72SD-N	81⅞"	3	64.1	9	½
Freezers - Hold -10° to 0°F					
TSF-23SD-N	27"	1	19.03	3	½
TSF-49SD-N	54⅜"	2	39.9	6	⅓
TSF-72SD-N	81⅞"	3	63.8	9	¾



REFRIGERATOR MANUFACTURER **Turbo Air** TSR-49SD-N6



## Keeping It Clean!

The Self-Cleaning Condenser System cleans the condenser with a rotating brush that moves up and down 2-3 times a day, preventing any dust build-up.

To learn more visit: [www.turboairinc.com](http://www.turboairinc.com)





### Reach-Ins

- Stainless steel exterior and interior floor
- CFC-free polyurethane foam insulation
- 4 heavy-duty, adjustable, PE coated wire shelves per section
- Door locks and swivel casters come standard
- Utilizes environmentally friendly CFC-free refrigerant: Refrigerators R134a, Freezers R404A
- Digitally controlled temperature system and LED display
- Holding temperatures: Refrigerators 33° to 41°F, Freezers -10° to 10°F
- Self contained system
- Recessed handles
- 32.7" d x 82.3" h



## MAXX COLD

A Division of Legacy

Refrigerators	Freezers	Width	Doors	Cu Ft	Shelves
MXCR-23FD*	MXCF-23FD	26.8"	1	23	3
MXCR-49FD*	MXCF-49FD	53.9"	2	49	6
MXCR-72FD	MXCF-72FD	81"	3	72	9

\*ENERGY STAR



### Bottom Mount Reach-Ins

- Stainless steel front and sides
- White aluminum interior with stainless steel floor with covered corners
- CFC-free refrigerant - R290
- Self closing doors remain open at 90°
- Casters, 2 locking
- 32¾" d x 82¾" h
- 2 year parts/labor warranty, 5 year compressor warranty



Refrigerators, 33° to 41°F	Doors/Shelves	Cu Ft	Width	HP
AR23	1/3	23	26¾"	⅜
AR49	2/6	49	54"	½
Freezers, -10° to 10°F				
AF23	1/3	23	26¾"	⅜
AF49	2/6	49	54"	1



### Bottom Mount Reach-Ins

- Stainless steel exterior and interior
- Dixell digital controller
- Holding temperatures: Refrigerators 33° to 40°F, Freezers -8° to 0°F
- LED interior lighting
- Recessed door handle
- Magnetic door gasket
- 4" casters
- Environmentally friendly R290 refrigerant
- 31½" d x 84" h
- 2 year parts and labor warranty, 5 year compressor part warranty



MBF8501GR

Refrigerators	Width	Doors	Shelves	Cu Ft	HP
MBF8505GR	27"	1	3	19.1	⅓
MBF8507GR	54¾"	2	6	43.8	⅓
Freezers					
MBF8501GR	27"	1	3	19.1	½
MBF8503GR	54¾"	2	6	43.8	¾

### Reach-In Refrigerators and Freezers

- Stainless steel exterior and interior
- Energy efficient interior LED light
- Environmentally friendly R290 hydrocarbon refrigerant
- Solid state digital controller with temperature alarms and LED display (Fahrenheit or Celsius)
- Cabinet and doors are insulated with 2¾" of CFC free, foamed in place polyurethane
- Field reversible doors
- Evaporator coils are epoxy electrocoated (E-Coat) to help fight corrosion
- Energy efficient automatic hot gas condensate evaporator
- Stainless steel shelf supports
- (3) epoxy coated wire shelves per section
- Standard with 4" casters (two with brakes)
- 33¾" d x 79½" h with 4" casters



R1A-FS(L)

<b>One Section - 23.1 Cu Ft</b>	
R1A-FS(L)	Refrigerator, 27½" w
F1A-FS(L)	Freezer, 27½" w
<b>Two Section - 50.37 Cu Ft</b>	
R2A-FS	Refrigerator, 55" w
F2A-FS	Freezer, 55" w

# REFRIGERATION EQUIPMENT

## Undercounter Refrigerators

- All stainless steel front, top and sides
- Natural refrigerant
- Adjustable, heavy-duty PVC coated wire shelves
- Self-contained system
- Holds 33° to 38°F
- Foamed-in-place high density polyurethane insulation (CFC Free)
- 5" swivel casters standard – legs available
- 3 year parts & labor warranty, 5 year compressor warranty
- 30 $\frac{3}{8}$ "d x 29 $\frac{3}{4}$ "h (height does not include 6 $\frac{1}{4}$ " for casters or 6" for optional legs)
- 115V

	Length	Doors	Shelves
TUC-27-HC	27 $\frac{3}{8}$ "	1	2
TUC-48-HC	48 $\frac{3}{8}$ "	2	4
TUC-27F-HC	27 $\frac{3}{8}$ "	1	2
TUC-48F-HC	48 $\frac{3}{8}$ "	2	4



## AdvantEDGE™ Undercounter Refrigerators and Freezers

- Stainless steel interior and exterior
- R290 refrigerant
- Front breathing design
- Automatic condensate vaporizer
- Automatic defrost
- Capillary tube system
- Self-closing doors
- Condenser filter screen
- Recessed pocket pull handles
- Vinyl coated shelves
- 6" casters standard
- 30" d x 36" h
- 3 year parts and labor, 5 year compressor warranty

Refrigerators	Length	Doors	Shelves	Cu Ft	HP
NLUR27A	27 $\frac{1}{2}$ "	1	1	7.5	$\frac{1}{8}$
NLUR36A	36"	2	2	10	$\frac{1}{8}$
NLUR48A	48"	2	2	13.7	$\frac{1}{8}$
NLUR60A	60"	2	2	17.5	$\frac{3}{8}$
NLUR72A	72"	3	3	21.0	$\frac{3}{8}$

Freezers	Length	Doors	Shelves	Cu Ft	HP
NLUF27A	27 $\frac{1}{2}$ "	1	1	7.5	$\frac{1}{8}$
NLUF48A	48"	2	2	13.7	$\frac{1}{2}$
NLUF60A	60"	2	2	17.5	$\frac{1}{2}$



## Undercounter Reach-In Refrigerator

- Stainless steel exterior front, sides and top
- UL approved for outdoor use
- Interior LED lighting
- ADA Compliant
- 1 door, 3 shelves

HR24B 23.4"w x 24.5"d x 31.5"h



## Steelheart Undercounter Refrigerators and Freezers

- Extruded aluminum flush mount handles
- Anodized aluminum shelf supports adjustable in  $\frac{1}{2}$ " increments
- 4" casters (two with brakes)
- Environmentally friendly R290 hydrocarbon refrigerant
- 27"w x 30"d x 33 $\frac{63}{100}$ "h

### Door Models

- 1 epoxy coated shelf per section
- Spring assisted self-closing stepped door design with stay-open feature
- Magnetic door gasket is easily removable for cleaning

### Drawer Models

- Stainless steel drawer slides with acetal rollers
- Drawers hold (1) 12" x 20" full size pan

Refrigerators	Freezers	
UR27A	UF27A	1 Door
UR27A-D2	UF27A-D2	2 Drawers



UF27A



## Worktop Refrigerators

- Natural, environmentally-safe, high-efficiency R290 refrigerant
- Stainless steel top, front and end panels
- Automatic, hot gas condensate evaporator
- Non-corrosive, plasticized fin evaporator coil
- Spring loaded, self-closing doors
- Heavy-duty, epoxy-coated steel shelves
- 2" non-CFC polyurethane foam insulation
- Completely enclosed, vented and removable case back
- Easily serviceable back mounted compressor
- Electronic controller w/digital display and hi-low alarm
- 5" casters
- 32 $\frac{3}{16}$ "d x 35 $\frac{1}{4}$ "h



**Continental**  
Refrigerator



	Length	Doors	Shelves	HP
SW27N	27 $\frac{1}{2}$ "	1	1	$\frac{1}{5}$
SW48N	48"	2	2	$\frac{1}{5}$
SW60N	60"	2	2	$\frac{1}{5}$
SW72N	72"	3	3	$\frac{1}{5}$



## AdvantEDGE™ Refrigerated Chef Bases

- Stainless steel exterior, interior and drawers
- Full marine edge top (except NLCB36)
- NLCB36 has a flat top
- Full size pan adapter bars (pans not included)
- R290 refrigerant
- Digital temperature indicator
- Temperature range: 34°F to 38°F
- 4" casters
- 31" d x 25 $\frac{1}{2}$ " h
- 3 year parts & labor, 5 year compressor warranty

	Length	Drawers	Pan Capacity	HP
NLCB36	36"	2	2	$\frac{1}{5}$
NLCB48	48"	2	4	$\frac{1}{5}$
NLCB53	53"	2	6	$\frac{1}{5}$
NLCB60	60"	2	6	$\frac{1}{5}$
NLCB72	72"	4	8	$\frac{1}{5}$
NLCB84	84"	4	10	$\frac{3}{5}$
NLCB96	96 $\frac{1}{16}$ "	4	12	$\frac{3}{5}$

## Super Deluxe Undercounter Refrigerators and Freezers

- Maintenance free, self-cleaning condenser
- Digital temperature control system
- 4" swivel casters
- Stainless steel exterior, interior and shelves
- LED interior lighting and fan control
- Environmentally friendly hydrocarbon refrigerant
- 3 year parts and labor warranty and additional 2 year compressor warranty
- 30" d x 30 $\frac{5}{8}$ " h
- 115V

Refrigerators	Length	Doors	Shelves	HP
TUR-28SD-N	27 $\frac{1}{2}$ "	1	1	$\frac{1}{5}$
TUR-36SD-N6	36 $\frac{1}{4}$ "	2	2	$\frac{1}{5}$
TUR-48SD-N	48 $\frac{1}{4}$ "	2	2	$\frac{1}{5}$
TUR-60SD-N	60 $\frac{1}{4}$ "	2	2	$\frac{1}{5}$
TUR-72SD-N	72 $\frac{5}{8}$ "	3	3	$\frac{1}{5}$
Freezers				
TUF-28SD-N	27 $\frac{1}{2}$ "	1	1	$\frac{1}{5}$
TUF-48SD-N	48 $\frac{1}{4}$ "	2	2	$\frac{1}{5}$
TUF-60SD-N	60 $\frac{1}{4}$ "	2	2	$\frac{1}{2}$



TUF-60SD-N



REFRIGERATOR MANUFACTURER  
**Turbo air**

High quality stainless steel exterior, interior and shelves

# REFRIGERATION EQUIPMENT



## Chef Bases

- Oversized, environmentally friendly R134a refrigeration system
- Drawer fronts are stainless steel with recessed handles
- Drawers hold 2 to 3 pans depending on model
- Foamed-in-place polyurethane high density cell insulation (CFC Free)
- 4" plate casters
- Exterior mounted digital temperature display
- Height does not include 5" for casters or 6" for optional legs
- 3 year parts and labor warranty and an additional 2 year warranty on compressor

	L x D x H	Drawers
TRCB-36	36 <sup>3</sup> / <sub>8</sub> " x 32 <sup>1</sup> / <sub>8</sub> " x 20 <sup>3</sup> / <sub>8</sub> "	2
TRCB-52	51 <sup>1</sup> / <sub>8</sub> " x 32 <sup>1</sup> / <sub>8</sub> " x 20 <sup>3</sup> / <sub>8</sub> "	2
TRCB-72	72 <sup>3</sup> / <sub>8</sub> " x 32 <sup>1</sup> / <sub>8</sub> " x 20 <sup>3</sup> / <sub>8</sub> "	4



**True**  
REFRIGERATION®

## Undercounter Refrigerators

- Stainless steel exterior and interior with reinforced stainless steel top
- Dixell digital controller
- Maintains temperatures between 33° to 40°F
- Recessed door handle
- Self-closing door with stay open feature
- Magnetic door gasket
- Environmentally friendly R290 refrigerant
- 2" casters
- 30"d x 34<sup>1</sup>/<sub>8</sub>"h
- 2 year parts and labor warranty, 5 year compressor part warranty



	Width	Doors	Shelves	Cu Ft
MGF8401GR	27 <sup>9</sup> / <sub>16</sub> "	1	1	7.15
MGF8402GR	48 <sup>1</sup> / <sub>4</sub> "	2	2	13.38



MGF8402GR



ACP8SQ



## Compact Refrigerated Countertop Prep Units

- Stainless steel construction
- Completely self-contained
- Includes pan supports and 1/2 size pans and covers
- Temperature range 33° to 41°F
- 1 year parts and labor warranty
- 25<sup>3</sup>/<sub>4</sub>"d x 9<sup>1</sup>/<sub>8</sub>"h

	Capacity	Width
ACP4SQ	(4) 1/2 Size Pans	15"
ACP8SQ	(8) 1/2 Size Pans	27 <sup>1</sup> / <sub>2</sub> "



## Refrigerated Chef Bases

- Stainless steel front, sides and top
- Stainless steel drawer facings, linings and frames
- Electronic thermostat with external digital LED display
- Casters, 2 locking
- 32"d x 26"h
- 1/2 hp
- 2 year parts and labor warranty and 5 year compressor warranty

	Drawers	Width
ARCB36	2	38"
ARCB48	2	50"
ARCB60	2	62"
ARCB72	4	74"



ARCB48

## Griddle Stands

- Stainless steel interior and exterior
- Reinforced stainless steel work top
- Easy-glide drawers hold 6" deep pans side-by-side
- Non-corrosive, plasticized fin evaporator coil
- 4" casters on support plates
- 34 $\frac{3}{4}$ "d x 26 $\frac{3}{8}$ "h

Refrigerators	Length	Drawers	Full Size Pan Capacity	HP
D36GN	36"	2	2	$\frac{1}{8}$
D48GN	48"	2	4	$\frac{1}{8}$
D60GN	60"	2	6	$\frac{1}{4}$ +
D72GN	72"	4	6	$\frac{1}{4}$ +
D84GN	84"	4	8	$\frac{1}{4}$ +
D96GN	96"	4	10	$\frac{1}{4}$ +
D108GN	108"	6	12	$\frac{1}{2}$
Freezers	Length	Drawers	Full Size Pan Capacity	HP
DL48GF	48"	2	4	$\frac{1}{4}$
DL60GF	60"	2	6	$\frac{1}{8}$
DL72GF	72"	4	6	$\frac{1}{8}$
DL84GF	84"	4	8	$\frac{1}{2}$

**Continental**  
Refrigerator



D36GN



REFRIGERATION EQUIPMENT



TST-60SD-N



## Super Deluxe Sandwich/Salad Unit

- Maintenance free, self-cleaning condenser
- High quality stainless steel exterior, interior and shelves
- Innovative "Cold Bunker System" maintains temperature evenly
- Isolated food pan area to prevent food spillage
- 4" swivel casters
- 3 year parts and labor warranty and additional 2 year compressor warranty
- 30"d x 37"h

REFRIGERATOR MANUFACTURER  
**Turbo air**

	Length	Doors	Shelves	Pan Capacity	HP
TST-28SD-N	27 $\frac{1}{2}$ "	1	1	8	$\frac{1}{8}$
TST-48SD-N	48 $\frac{1}{4}$ "	2	2	12	$\frac{1}{4}$
TST-60SD-N	60 $\frac{1}{4}$ "	2	2	16	$\frac{1}{4}$
TST-72SD-N	72 $\frac{5}{8}$ "	3	3	18	$\frac{1}{8}$

## Food Prep Tables

- Stainless steel front, top and ends with corrosion resistant GalFan coated steel back
- Patented forced-air refrigeration system holds 33° to 41°F
- $\frac{1}{2}$  size, 4" deep polycarbonate food pans and 8" deep,  $\frac{1}{2}$ " thick, removable cutting board included
- 2 $\frac{1}{2}$ " casters
- 3 year parts and labor warranty with an additional 2 year warranty on compressor
- 31 $\frac{1}{2}$ "d x 45 $\frac{3}{4}$ "h

**True**  
REFRIGERATION

	Length	Drawers	Doors	Shelves	Pan Capacity
TFP-32-12M-D-2	32 $\frac{1}{8}$ "	2	-	-	12
TFP-32-12M	32 $\frac{1}{8}$ "	-	1	2	12
TFP-48-18M	48 $\frac{1}{8}$ "	-	2	4	18



TFP-32-12M-D-2

TFP-32-12M



# REFRIGERATION EQUIPMENT



NLSMP27-12A



NLSMP27-12A



## AdvantEDGE™ Sandwich Prep Tables

- Stainless steel interior, exterior top, front and ends
- ½ size pans included
- Casters standard
- Automatic defrost
- Front breathing design
- Condenser filter screen
- Locking pan adapter bars
- Temperature ranges: 34° to 38°F in storage area, 33° to 41°F in refrigerated pan wells
- R290 refrigerant
- 115V
- 3 year parts & labor warranty, 5 year compressor warranty

Includes a 9½" d polyethylene cutting board

	Length	Doors	Shelves	Pan Capacity	HP	Mega Tops 33"d x 44½"h	Length	Doors	Shelves	Pan Capacity	HP
30"d x 43¾"h											
NLSP27-8A	27½"	1	1	8	½	NLSMP27-12A	27½"	1	1	12	½
NLSP36-10A	36"	2	2	10	½	NLSMP36-15A	36"	2	2	15	½
NLSP48-12A	48"	2	2	12	¾	NLSMP48-18A	48"	2	2	18	¾
NLSP60-16A	60"	2	2	16	¾	NLSMP60-24A	60"	2	2	24	¾
NLSP72-18A	72"	3	3	18	¾	NLSMP72-30A	72"	3	3	30	¾

## Sandwich Unit Refrigerators

- Stainless steel top, front and end panels, aluminum back and interior
- Natural, environmentally-safe, high-efficiency R290 refrigerant
- Unique air flow distribution allows pan product to maintain 33° to 41°F
- Heavy-duty, epoxy-coated steel shelves
- Electronic controller w/digital display and hi-low alarm
- 5" casters
- Includes ½ size 4" deep pans
- 115V



SW36N10 12" deep, full length nylon cutting board



SW48N12M 10" deep, full length nylon cutting board



Standard	Length	Doors	Shelves	Pan Capacity	HP	Mighty Tops	Length	Doors	Shelves	Pan Capacity	HP
32¾" d x 42¼" h						35" d x 42¼" h					
SW27N8	27½"	1	1	8	½	SW27N12M	27½"	1	1	12	½
SW32N8	32"	1	1	8	½	SW32N12M	32"	1	1	12	½
SW36N10	36"	2	2	10	½	SW36N15M	36"	2	2	15	½
SW48N8	48"	2	2	8	¼+	SW48N12M	48"	2	2	12	¼+
SW48N10	48"	2	2	10	¼+	SW48N18M	48"	2	2	18	¼+
SW48N12	48"	2	2	12	¼+	SW60N12M	60"	2	2	12	½+
SW60N8	60"	2	2	8	½+	SW60N18M	60"	2	2	18	½+
SW60N12	60"	2	2	12	½+	SW60N24M	60"	2	2	24	½+
SW60N16	60"	2	2	16	½+	SW72N18M	72"	3	3	18	½+
SW72N12	72"	3	3	12	½+	SW72N27M	72"	3	3	27	½+
SW72N18	72"	3	3	18	½+	SW72N30M	72"	3	3	30	½+

## Sandwich/Salad Prep Tables

- All stainless steel front, top & sides
- Natural refrigerant
- Holds 33° to 41°F
- Work surface 36" high
- Full length removable polyethylene cutting board
- Standard 1/2 size 4" deep, clear polycarbonate insert pans
- Includes 5" casters (height does not include 6 1/4" for casters or 6" for optional legs)
- 3 year parts and labor warranty and an additional 2 year compressor warranty



Mega Top 34 1/8" d x 40 3/8" h	Length	Doors	Shelves	Pan Capacity	HP
TSSU-48-18M-B-HC	48 3/8"	2	4	18	1/3
TSSU-60-24M-B-ST-HC†	60 3/8"	2	4	24	1/3
Standard 30 3/8" d x 36 3/4" h					
TSSU-27-08-HC†	27 3/8"	1	2	8	1/5
TSSU-48-12-HC	48 3/8"	2	4	12	1/3
TSSU-60-16-HC†	60 3/8"	2	4	16	1/3

†Not CE



TSSU-48-12-HC



REFRIGERATION EQUIPMENT



MSF8302GR



## Refrigerated Sandwich Prep Tables

- Stainless steel exterior and interior
- Environmentally friendly R290 refrigerant
- Dixell digital controller
- Includes stainless steel food pans
- 10" poly cutting board
- Recessed door handle
- Self-closing door with stay open feature
- Magnetic door gasket
- 5" casters
- 2 year parts and labor warranty, 5 year compressor part warranty

Standard	L x D x H	Shelves	Pan Capacity	HP
MSF8302GR	48.25" x 30" x 44.25"	2	12	1/7
Mega Top				
MSF8307GR	60.24" x 33.98" x 46.57"	2	24	1/5
MPF8203GR	93" x 33.1" x 44"	6	12	1/4

## Prep Refrigerators

- Environmentally friendly R290 hydrocarbon refrigerant
- Cabinet and doors are insulated with 2" CFC free, foamed in place polyurethane
- Exclusive "stepped" door design to protect door gasket
- Spring assisted self-closing doors with stay open feature
- Extruded aluminum flush mount door handle
- Field reversible doors
- Magnetic door gasket is easily removable for cleaning
- Innovative air distribution system distributes air evenly to maintain product temperature
- Provided with a full complement of polycarbonate plastic 1/2 size pans, 4" deep
- Rails will also accept 6" deep pans for 50% more pan volume
- 48" l x 10" w x 1/2" thick white polyethylene cutting board is standard
- E-coated evaporator coil
- One epoxy coated shelf per section is standard

Sandwich Top	Depth	Pan Capacity
SR48A-12	30"	12
Mega Top		
SR48A-18M	34"	18



- Anodized aluminum shelf supports adjustable in 1/2" increments
- Removable stainless steel prep guard simplifies cleanup from accidental rail pan drips and spills
- Standard with 6" casters (two with brakes)
- 10 ft. cord and plug
- 48" w x 44 1/4" h with 6" casters

Ready to learn more about these great products?  
**PLAY VIDEO**



SR48A-18M



# REFRIGERATION EQUIPMENT



## Pizza Prep Tables

- All stainless steel front, top and sides
- Corrosion-resistant GalFan coated steel back
- Polyurethane foam insulation
- Holds 33° to 41°F
- Full length removable cutting board
- Natural refrigerant
- 5" casters
- 3 year parts and labor with an additional 2 year warranty on compressor
- 33 $\frac{5}{8}$ "d x 38 $\frac{7}{8}$ "h
- 115V

	Length	Drawers	Doors	Shelves	Pan Capacity
TPP-AT-44-HC	44 $\frac{5}{8}$ "	-	1	2	6
TPP-AT-67-HC	67 $\frac{3}{8}$ "	-	2	4	9
TPP-AT-67D-4-HC	67 $\frac{3}{8}$ "	4	-	-	9
TPP-AT-93-HC	93 $\frac{1}{2}$ "	-	3	6	12



TPP-AT-67-HC

## Forced Air Pizza Prep Tables

- Performance rated refrigeration system uses environmentally safe R-134a refrigerant
- Heavy gauge 300 Series stainless steel top, front and end panels, aluminum interior
- Extra-wide 19" high density, full length nylon cutting board
- Spring loaded, self-closing doors
- Offers more refrigerated storage capacity by utilizing space above condensing unit with either a door or drawer that can accommodate a 12" x 20" x 6" pan
- Heavy-duty, epoxy-coated steel shelves
- 5" high swivel casters
- Electronic controller w/digital display and hi-low alarm
- Insulated lids
- 115V
- 1/2 hp
- 36 $\frac{3}{8}$ "d x 39 $\frac{1}{16}$ "h

	Length	Doors	Shelves
CPA43	43"	1	1
CPA60	60"	2	2
CPA68	68"	2	2
CPA93	93"	3	3



CPA68



NLPT93



## AdvantEDGE™ Pizza Prep Table

- Stainless steel exterior with aluminum back, galvanized bottom
- Stainless steel interior
- Automatic defrost
- Insulated rail covers with hold open hinges
- R290 refrigerant
- 19" deep reversible cutting board
- 1/3 size pans included
- 36 $\frac{3}{8}$ "d x 42 $\frac{1}{2}$ "h with 6" casters
- 3 year parts & labor warranty, 5 year compressor warranty



	Length	Doors	Shelves	Pan Capacity	HP
NLPT44	44.4"	1	2	6	3/8
NLPT67	67"	2	4	9	3/8
NLPT93	93.3"	3	6	12	1/2





BDVACM-200

## Black Diamond Vertical Air Curtain Merchandisers

- Brilliant internal LED illumination on each shelf helps drive impulse sales
- Stainless steel construction with safety glass on sides
- Digital temperature controller and display
- Stainless steel shelves
- Night curtain
- Ventilated cooling system
- Automatic defrost
- 4 casters (two with brakes)
- 110V



**Admiral Craft**  
Equipment Corp.

	W x D x H	Shelves
BDVACM-200	36½" x 25" x 49¼"	2
BDVACM-220	19" x 26½" x 68¾"	3
BDVACM-250	24" x 29¾" x 67"	3

## Countertop Refrigerated Display Cases

- Stainless steel exterior and interior with black frames
- Rear mount compressor with environmentally friendly R290 refrigerant
- LED interior lighting
- Dixell digital controller
- 2 stainless steel shelves and rear sliding doors
- Defog feature ensures the glass stays clear
- Maintains temperatures between 33° to 41°F
- Magnetic door gasket
- ½ hp
- 22¼"d x 26¾"h
- 1 year parts and labor warranty, 5 year compressor part warranty

Curved Glass	Width	Cu Ft
CRDC-35	27¾"	3.5
CRDC-46	35¾"	4.6
Square Glass		
CRDS-42	27¾"	4.2
CRDS-56	35¾"	5.6



CRDC-35



TDM-R-48-GE/GE-W-W



## Bakery Display Cases

- Curved glass front and side panels are single-pane tempered glass
- LED interior lighting, safety shielded
- 150 lb capacity per shelf
- White interior and exterior
- Electronic temperature control
- Standard temperature range maintains cabinet temperatures of 33° to 41°F
- 3 year warranty on all parts and labor and an additional 2 year warranty on compressor
- 39"d x 49½"h
- 115V



Refrigerated	Width	Shelves	HP
TDM-R-48-GE/GE-W-W	48¼"	3	½
TDM-R-59-GE/GE-W-W	59¼"	3	½
Dry			
TDM-DC-48-GE/GE-W-W	48¼"	3	-
TDM-DC-59-GE/GE-W-W	59¼"	3	-
Dual Zone			
TDM-DZ-59-GE/GE-W-W	59¼"	6	¼
TDM-DZ-77-GE/GE-W-W	77¼"	6	¼

Various exterior colors and interior colors available

# REFRIGERATION EQUIPMENT



TOM-36DXB-N

REFRIGERATOR MANUFACTURER  
**Turbo air**



TCGB-48UF-W(B)-N



## Vertical Display Cases

- Designed to drive impulse sales
- LED interior lighting
- Reinforced tempered glass
- Energy saving night curtain
- Self-cleaning condenser
- Foamed with polyurethane, high-density cell insulation (CFC free)
- Perforated interior back wall and top for improved airflow
- 4 shelves
- Environmentally friendly R290 refrigeration
- ¾ hp x 2
- 34¼" d x 78⅞" h
- 2 year parts and labor warranty with additional 3 year warranty on compressor

Glass Side Panels	Length	Cu Ft
TOM-36DXB-N	36"	11
Solid Side Panels		
TOM-48DXB-N	48"	14.9
TOM-60DXB-N	60"	18.9

## Bakery Display Cases

- Refrigerated case holds 33° to 41°F
- Straight tempered front glass for full product visibility
- Self-cleaning condenser
- LED interior lighting
- Adjustable, tempered glass shelves with stainless steel front and back edges
- High-density polyurethane insulation (CFC free)
- Sliding rear doors for product loading & unloading
- Environmentally friendly R290 refrigeration
- 34¼" d x 50⅞" h
- 2 year parts and labor warranty with additional 3 year warranty on compressor

Refrigerated	Length	Shelves	Cu Ft	HP
TCGB-36UF-W(B)-N	36½"	2	11.8	⅓
TCGB-48UF-W(B)-N	48½"	2	15.6	⅓
TCGB-60UF-W(B)-N	60½"	2	19.4	¾
TCGB-72UF-W(B)-N	72½"	2	23.2	¾
Combination Refrigerated & Dry				
TCGB-60UF-CO-W(B)-N	60½"	4	10.3 x 2	⅓
TCGB-72UF-CO-W(B)-N	72½"	4	12.2 x 2	⅓

## Countertop Glass Door Merchandisers

- Black exterior cabinet with black door frame and white interior
- Environmentally friendly R600a refrigerant
- CTD-3S features illuminated sign on top
- Foamed-in-place high density polyurethane insulation
- Double pane glass door with recessed door handle
- Pre-installed removable PVC coated wire shelves
- Maintains temperatures between 33° to 41°F
- LED interior lighting
- Leveling legs
- 2 year parts and labor warranty, 5 year compressor part warranty

CTD-3



	W x D x H	Shelves	Cu Ft
CTD-3	17⅞" x 18⅞" x 27½"	3	3
CTD-3S	18⅞" x 16¾" x 32¼"	3	3
CTD-5	21¼" x 20⅝" x 32¼"	4	5



CTD-3S





## Wine Serving & Aging Cabinets

- Black finish, stainless steel door frame
- Beechwood shelves
- Multi-function digital temp. controls
- Temperature ranges: Single Zone(S) 41° to 64.4°F, Dual Zone(D) upper zone: 41° to 50°F, lower zone: 50° to 64.4°F
- Thermostatic cabinet
- Fan forced evaporator cooling
- 24" wide
- 110V
- 1 year parts and labor and 3 year compressor warranty

	H x D	Shelves	Bottle Capacity†
USF54D	36" x 24"	6	46
USF168D	71½" x 27"	14	154
USF168S	71½" x 27"	15	165

†Capacities listed for standard bottle size

Keep red and white wines at optimal temperatures



USF168D

eurodib



USF54D



## AdvantEdge™ Bottle Coolers

- Black vinyl coated steel exterior front, sides and back
- Stainless steel top with integrated glass rail and stainless steel sliding lids
- Durable galvanized interior
- Air cooled condensing unit
- R290 refrigerant
- Adjustable temperature control
- Removable bottle opener cap catcher
- 3 year parts & labor, 5 year compressor warranty

	Length	HP	Capacity 12 oz Bottles/Cans
NLBC50	50"	¾	377/857
NLBC65	64½"	¾	539/1191
NLBC80	80½"	¾	715/1575
NLBC95	95"	¾	877/1893

## Bottle Coolers

- Wear resistant, textured baked black enamel finish with stainless steel countertop and slide lids
- Galvanized steel interior
- Adjustable, heavy-duty epoxy-coated steel wire storage bin dividers
- Heavy-duty bottle cap opener
- Automatic, energy saving, non-electric condensate evaporator
- High density, non-CFC polyurethane foamed-in-place insulation
- Environmentally-safe R-134a refrigerant
- 29½"d x 33½"h (CBC50 is 28½"d)

**Continental**  
Refrigerator

	Length	HP	Capacity 12 oz Bottles/Cans
CBC37	37"	½	12/18½ cs
CBC50	50"	½	18/27 cs
CBC64	64"	½	25/37 cs
CBC95	95"	½	40/59 cs

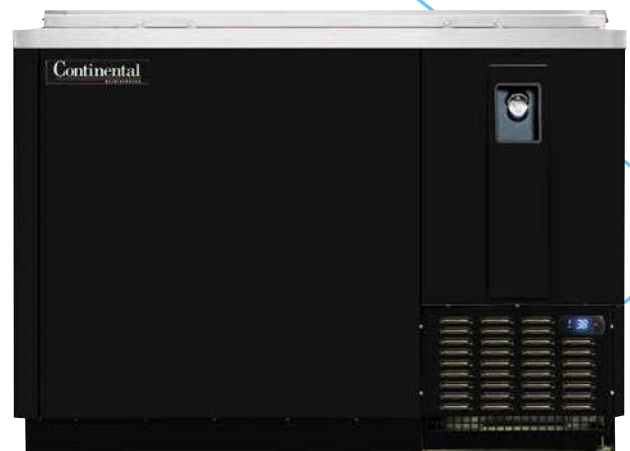

CBC50

# REFRIGERATION EQUIPMENT



BB50N

## Back Bar Storage Coolers

- Textured baked black enamel finish exterior, stainless steel countertop
- Interior back and side panels with reinforced stainless steel floor
- Cylinder-keyed security lock in each door
- Automatic, hot gas condensate evaporator
- High density, non-CFC polyurethane foamed-in-place insulation
- LED interior lighting
- Natural, environmentally-safe, high-efficiency R290 refrigerant
- Extra large, balanced evaporator coil
- 29<sup>1</sup>/<sub>16</sub>"d x 34<sup>3</sup>/<sub>4</sub>"h



	Length	Doors	Shelves	Keg Capacity <sup>^</sup>	HP
BB50N	50"	2	4	2	1/4
BB59N	59"	2	4	3	1/4
BB69N	69"	2	4	3	1/4
BB79N	79"	3	6	4	1/2
BB90N	90"	3	6	5	1/2

<sup>^</sup>Keg capacity based on straight wall kegs

## Bottle Coolers

- SD models boast a stainless steel exterior
- SB models have an attractive wear-resistant black vinyl exterior
- Self-cleaning condenser equipped, maintenance free
- Hydrocarbon refrigerant
- Positive guided forced air cooling system chills bottles on top first
- Built-in removable bottle cap opener and cap catcher
- Holds 33° to 38°F
- High density, CFC free polyurethane insulation
- 3 year parts and labor warranty and additional 2 year compressor warranty
- 4" swivel casters
- 26<sup>1</sup>/<sub>2</sub>"d x 33<sup>1</sup>/<sub>4</sub>"h

	Length	Doors	Dividers	Cu Ft	HP
TBC-50SB-N6	50"	2	3	13.5	1/5
TBC-50SD-N6	50"	2	3	13.5	1/5
TBC-65SB-N6	64 <sup>3</sup> / <sub>8</sub> "	2	4	18.5	1/5
TBC-65SD-N6	64 <sup>3</sup> / <sub>8</sub> "	2	4	18.5	1/5
TBC-80SB-N	80 <sup>1</sup> / <sub>2</sub> "	3	5	22.6	1/3
TBC-80SD-N	80 <sup>1</sup> / <sub>2</sub> "	3	5	22.6	1/3



TBC-50SB-N6

REFRIGERATOR MANUFACTURER  
**Turbo air**



TBB-3SG-N



## Back Bar Coolers

- Stainless steel countertop and interior floor, wear-resistant black vinyl exterior
- Adjustable, heavy-duty polyethylene coated wire shelves
- Double pane Low-E glass on glass door (SG models)
- High density foamed-in-place CFC free polyurethane insulation
- Side mount compressor unit
- Self-cleaning condenser
- LED interior lighting
- All N6 models use R-600a refrigerant
- All N Models use R290 refrigerant
- Holds 33° to 38°F
- 3 year parts and labor warranty and an additional 2 year warranty on compressor

Solid	L x D x H	Doors	Shelves	Cu Ft	HP
TBB-3SB-N6	69" x 27 <sup>1</sup> / <sub>4</sub> " x 37 <sup>1</sup> / <sub>8</sub> "	2	6	23	1/5
TBB-4SB-N	90 <sup>3</sup> / <sub>8</sub> " x 27 <sup>1</sup> / <sub>4</sub> " x 37 <sup>1</sup> / <sub>8</sub> "	3	8	36.47	1/3
Glass					
TBB-2SG-N	58 <sup>1</sup> / <sub>2</sub> " x 27 <sup>1</sup> / <sub>4</sub> " x 37 <sup>1</sup> / <sub>8</sub> "	2	6	19	1/5
TBB-3SG-N	69" x 27 <sup>1</sup> / <sub>4</sub> " x 37 <sup>1</sup> / <sub>8</sub> "	2	6	23	1/5
TBB-4SG-N	90 <sup>3</sup> / <sub>8</sub> " x 27 <sup>1</sup> / <sub>4</sub> " x 37 <sup>1</sup> / <sub>8</sub> "	3	8	36.47	1/3



## Back Bar Coolers

- Exterior – heavy-duty, wear-resistant laminated black vinyl front and sides with matching black aluminum back
- Heavy gauge all stainless steel countertop
- Natural refrigerant
- Heavy-duty, black PVC-coated wire shelving
- LED interior lighting
- Foamed-in-place, high density polyurethane insulation (CFC free)
- 3 year parts and labor warranty with an additional 2 year warranty on compressor
- 27<sup>3</sup>/<sub>4</sub>"d x 37"h



TBB-2G-HC-LD



Solid Doors	Length	Doors	Shelves	Capacity ½ Barrel/12 oz Cans	HP
TBB-2-HC	58 <sup>7</sup> / <sub>8</sub> "	2	4	2/88	¼
TBB-3-HC	69 <sup>1</sup> / <sub>8</sub> "	2	4	3/112	¼
TBB-4-HC	90 <sup>3</sup> / <sub>8</sub> "	3	6	4/152	¼
Glass Doors					
TBB-2G-HC-LD	58 <sup>7</sup> / <sub>8</sub> "	2	4	2/88	¼
TBB-3G-HC-LD	69 <sup>1</sup> / <sub>8</sub> "	2	4	3/112	¼

## AdvantEDGE™ Back Bar Refrigerators

- Stainless steel top and black vinyl coated steel exterior front, sides and back
- Self-contained forced air R290 refrigeration system
- Durable galvanized interior, LED interior lighting
- Slide out condensing unit
- ¾ hp
- Adjustable temperature range from 34° to 38°F
- Two epoxy coated shelves per door
- 29<sup>5</sup>/<sub>8</sub>"d x 37"h
- 3 year parts & labor warranty, 5 year compressor warranty



NLBB59-G



Solid	Length	Doors	Capacity 12 oz Bottles/Cans
NLBB59	59"	2	498/1084
NLBB69	69 <sup>1</sup> / <sub>8</sub> "	2	594/1299
NLBB79	80 <sup>3</sup> / <sub>4</sub> "	3	714/1566
NLBB95	95 <sup>1</sup> / <sub>4</sub> "	3	858/1875
Glass			
NLBB59-G	59"	2	498/1084
NLBB69-G	69 <sup>1</sup> / <sub>8</sub> "	2	594/1299
NLBB79-G	80 <sup>3</sup> / <sub>4</sub> "	3	714/1566
NLBB95-G	95 <sup>1</sup> / <sub>4</sub> "	3	858/1875

## AdvantEDGE™ Shallow Depth Back Bar Refrigerators

- Stainless steel top and black vinyl coated steel exterior front, sides and back
- R290 refrigeration system
- Durable galvanized interior, LED interior lighting
- Slide out condensing unit
- ¾ hp
- Adjustable temperature range from 34°F to 38°F
- Two epoxy coated shelves per door
- 26"d x 35<sup>5</sup>/<sub>8</sub>"h
- 3 year parts & labor warranty, 5 year compressor warranty



NLBB60NG



Solid	Length	Doors	Capacity 12 oz Bottles/Cans
NLBB48N	48 <sup>1</sup> / <sub>8</sub> "	2	336/714
NLBB60N	60 <sup>1</sup> / <sub>8</sub> "	2	468/966
NLBB72N	72 <sup>1</sup> / <sub>8</sub> "	3	588/1218
Glass			
NLBB48NG	48 <sup>1</sup> / <sub>8</sub> "	2	336/714
NLBB60NG	60 <sup>1</sup> / <sub>8</sub> "	2	468/966
NLBB72NG	72 <sup>1</sup> / <sub>8</sub> "	3	588/1218



## Back Bar Refrigerators

- Top is 1½" solid foamed stainless steel
- Bright stainless steel interior and black powder coated steel exterior front and sides
- Self-contained system uses environmentally friendly CFC free refrigerant - R290
- Interior LED lighting
- Electronic thermostat with digital LED display
- 3¼" casters (two lockable) are standard
- 24"d x 39½"h including casters
- 2 year parts and labor warranty and a 5 year compressor warranty

Solid	Length	Doors	Capacity 6-Packs
ABB48	49"	2	48
ABB60	61"	2	72
ABB72	73"	3	84
Glass			
ABB48G	49"	2	48
ABB60G	61"	2	72
ABB72G	73"	3	84



## AdvantEDGE™ Direct Draw Beer Cooler

- Stainless steel top, black vinyl steel front, sides and back
- Galvanized steel interior walls with stainless steel floor
- R290 refrigerant
- 3" diameter polished stainless steel draft tower
- Free flowing refrigeration system at all times to ensure uniformly cooled products
- LED interior light (except NLDD24)
- Slide out condensing unit
- Adjustable temperature control from 34° to 38°F
- 29½"d x 37"h (NLDD24: 30¾"d x 39½"h)
- 3 year parts & labor warranty, 5 year compressor warranty

	Length	Beer Towers	Keg Capacity	HP
NLDD24	23¾"	1 Single	1	½
NLDD59	59"	2 Singles	2	¾
NLDD69	69½"	2 Singles	3	¾
NLDD79	80¾"	1 Single, 1 Double	4	¾
NLDD95	95¼"	2 Doubles	5	¾



NLDD59



KC50N

## Keg Coolers

- Textured, baked black enamel finish exterior, stainless steel countertop, interior back and side panels with reinforced stainless steel floor
- Continuously cooled 3" diameter beer columns with lever faucets
- CO<sub>2</sub> pressure relief distributor and keg line tubing with clamps
- Easily removable stainless steel drip grate with convenient front mounted clean out drainage hose
- Cylinder-keyed security lock and magnetic snap-in gasket on each door
- Easily accessible and serviceable slide-out condensing unit
- Readily removable front, rear and side venting louvered grills
- Automatic, hot gas condensate evaporator
- Extra large, balanced evaporator coil
- LED interior lighting
- 29½"d x 34¾"h



	Length	Beer Columns	Keg Capacity <sup>^</sup>	HP
KC50N	50"	1	2	¼
KC59N	59"	2	3	¼
KC69N	69"	2	3	¼
KC79N	79"	2	4	½
KC90N	90"	2	5	½

<sup>^</sup>Keg capacity based on straight wall kegs



## Beer Dispensers

- Natural refrigerant unit available for all models
- Self-cleaning condenser
- All stainless steel exterior (SD models)
- Wear-resistant laminated black vinyl exterior (SB models)
- Stainless steel interior and countertop for easy cleaning and durability
- Side mount compressor unit
- Forced air cooling system
- 3" diameter stainless steel insulated beer columns
- Recessed handles
- Holds 33° to 38°F
- CFC free high-density polyurethane insulation
- 3 year parts and labor warranty with an additional 2 year warranty on compressor
- 27<sup>1</sup>/<sub>8</sub>"d x 37" h
- 4" casters standard

REFRIGERATOR MANUFACTURER  
**Turbo air**



TBD-4SB-N

	Length	Doors	Keg Capacity <sup>^</sup>	HP
TBD-2SB-N6	58 <sup>3</sup> / <sub>4</sub> "	2	2	1/5
TBD-2SD-N6	58 <sup>3</sup> / <sub>4</sub> "	2	2	1/5
TBD-3SB-N	69 <sup>1</sup> / <sub>2</sub> "	2	3	1/3
TBD-3SD-N	69 <sup>1</sup> / <sub>2</sub> "	2	3	1/3
TBD-4SB-N	90 <sup>1</sup> / <sub>2</sub> "	3	4	1/3
TBD-4SD-N	90 <sup>1</sup> / <sub>2</sub> "	3	4	1/3

<sup>^</sup>Half barrel kegs

## Direct Draw Beer Dispensers

- Exterior – heavy-duty, wear-resistant laminated black vinyl front and sides with matching black aluminum back and stainless steel top
- Stainless steel interior floor with 1/2" lip
- 3" dia stainless steel insulated beer columns
- Natural refrigerant
- Provides ice cold beer 33° to 38°F
- 1/4 hp
- 3 year warranty on all parts and labor and an additional 2 year warranty on compressor
- 27<sup>1</sup>/<sub>8</sub>"d x 37" h



TDD-3-HC

	Length	Doors	1/2 Barrel Keg Capacity
TDD-2-HC	58 <sup>7</sup> / <sub>8</sub> "	2	2
TDD-3-HC	69 <sup>1</sup> / <sub>2</sub> "	2	3



TBR48-RISZ1-L-B-GG-1



## Bar Refrigerators

- Black powder coated cold rolled steel with stainless steel countertop
- White LED interior lighting
- Three interior access ports
- Field reversible doors
- Self-contained, environmentally friendly R290 hydrocarbon refrigerant system
- Electronic temperature control with exterior digital display
- Temperature range from 33° to 38°F
- 3 year parts and labor warranty, 2 year compressor warranty
- 24<sup>7</sup>/<sub>8</sub>"d x 34<sup>3</sup>/<sub>4</sub>"h

	Length	Doors	Shelves	Capacity 12 oz Bottles/Cans
TBR48-RISZ1-L-B-SS-1	48"	2	6	76/43
TBR48-RISZ1-L-B-GG-1	48"	2	6	76/43
TBR48-RISZ1-L-B-11-1	48"	2	6	76/43
TBR60-RISZ1-L-B-SS-1	60"	2	6	101/63
TBR60-RISZ1-L-B-GG-1	60"	2	6	101/63
TBR60-RISZ1-L-B-11-1	60"	2	6	101/63
TBR72-RISZ1-L-B-SSS-1	72"	3	9	125/78
TBR72-RISZ1-L-B-GGG-1	72"	3	9	125/78
TBR72-RISZ1-L-B-111-1	72"	3	9	125/78

# REFRIGERATION EQUIPMENT



Kold Locker™

## Kold Locker™ Walk-Ins

10,000 models available to ship the same day!

- CFC-free polyurethane insulation
- Exclusive Capsule Pak™ refrigeration system
- Automatic condensate vaporizer - no drain line required on indoor units
- Three heights: 6'7" & 7'7" with floor, 7'4" floorless
- 77 cu ft to 1,000 cu ft, indoor or outdoor models
- 15 year panel warranty
- Sizes from 3'6" x 6' to 10' x 14'
- Exterior is 26 gauge corrosion resistant stucco embossed coated steel
- 26" wide self closing door
- FRP threshold



Fast-Trak®

## Fast-Trak® Walk-Ins

- CFC-free polyurethane insulation
- Exterior is 26 gauge corrosion resistant stucco embossed coated steel
- Digital thermometer
- Heavy-duty hinges
- Deadbolt locking handle
- Four heights: 8'7" & 7'7" with floor, 7'4" & 8'4" floorless
- 15 year panel warranty
- 30" or 36" wide self-closing door
- Cooler, freezer or combination cooler/freezer models available
- FRP threshold



## Walk-in Coolers & Freezers

- Extruded polystyrene or foamed-in-place polyurethane
- Standard and custom sized walk-in coolers and freezer
- Walk-ins are set up before shipment to assure quality control
- Full line of self-contained, remote and pre-assembled refrigeration units
- Exceptional quality and customer service



U.S. Cooler walk-ins are designed with flexibility to meet your needs. We offer a selection of standard sized walk-in coolers and freezers as well as custom sized units that can be built to your specifications.



A PRODUCT OF CRAIG INDUSTRIES, INC.





Walk-in coolers and freezers custom built to any size and shape. Please contact your local sales representative for details.

## Walk-In Coolers & Freezers

- Foamed-in-place urethane panels with speed-lok fastening system
- Full 36" x 78" door complete with structural frame
- Galvalume finish interior and exterior
- Freezers with 10 gauge smooth aluminum floor
- Full line of pre-assembled remote or self-contained refrigeration equipment
- Nominal sizes standard, custom available



## Polar-Pro® Swinging Door

- For walk-in coolers/freezers and personnel doors
- A great alternative to strip doors in high traffic areas
- Stainless steel hardware, self closing, even-plane hinge design with life-time rust proof guarantee
- Available in clear panels or choose from 5 colors with vision strips
- Standard model is .080" thick clear Polar grade PVC with "no-curl" reinforcement strip
- Universal, inside surface-mount hardware design

PP-C Fits Door Openings from 34" to 60" wide and up to 96" high



## M-Series Strip Door

- Polar reinforced PVC strips remain flexible to -20°F
- Reduces frost build-up and extends product shelf life
- Lowers refrigeration costs
- Mounting hardware and brackets are easy to install
- Easy to install and replace strips

M108-PR-4080 Fits Doorways up to 36" w x 78" h

## Chase Doors

A SENNECA COMPANY

### ColdGuard Cooler & Freezer Swing Doors

- Swing doors can be used on new applications, or to replace worn out OEM doors in walk-in coolers
- Unique design allows non-CFC foamed-in-place polyurethane insulation to lock in place with the fiberglass reinforced polymer (FRP) producing an extremely durable, insulated panel
- A variety of finishes are available including 26 gauge steel with USDA accepted white polyester finish, 26 gauge G-90 embossed galvanized steel, and galvalume, stainless steel, embossed white aluminum and smooth white aluminum
- Door panels are available in 4" and 6" panel thickness with an R Value of 28 and 37.1 respectively



REFRIGERATION EQUIPMENT

# REFRIGERATION EQUIPMENT

## Ice Machines

- Stainless steel exterior
- Slanted black plastic bin door
- Ice scoop included
- Air cooled condenser
- Produces half-diced cubes
- Removable air filter
- Undercounter models have 88 lb ice storage capacity
- 2 year parts and labor warranty, 5 year compressor part warranty



YR280-AP-161

Undercounter, 23½" x 28½" x 38¹³⁄₃₂"	Ice Production*
YR140-AP-161	142 lb
YR280-AP-161	283 lb
Modular, 30¹³⁄₆₄" x 24²⁹⁄₆₄" x 21⁴⁵⁄₆₄"	
YR450-AP-161	460 lb
YR800-AP-261	810 lb

Ice Bin		
CYR400P	30¼"w x 32¾"d x 41¼"h	396 lb Ice Storage
CYR700P	48¹⁄₃"w x 32½"d x 41"h	700 lb Ice Storage

\*Based on 70°F air and 50°F water temperature in a 24 hr period



KM-116BAJ



## Self-Contained Undercounter Cubers with Built-in Storage

- Air-cooled
- Durable stainless steel exterior
- Front-in, front-out airflow with removable air filter
- Slide-in door
- Power switch accessible without panel removal
- Includes scoop H-GUARD Plus Antimicrobial protection
- EverCheck™ alert system
- 6" legs

	Ice Production*	Ice Storage	W x D x H
KM-81BAJ	78 lb	38 lb	17¾" x 24" x 39"
KM-116BAJ	125 lb	53 lb	23¾" x 24" x 39"
KM-161BAJ	163 lb	78 lb	23¾" x 28" x 39"
KM-231BAJ	213 lb	80 lb	24" x 28" x 39"
KM-301BAJ	290 lb	100 lb	30" x 28" x 39"

\*Based on 70°F air and 50°F water temperature in a 24 hr period



## Ice Machines

- Air cooled
- All stainless steel
- User friendly design
- Includes two thermostats—bin and evaporator
- Easy to maintain and clean
- Timer included
- Adjustable feet standard with all the machines except CB249
- 3 year parts and labor and 5 year warranty on compressor



GB903A



Ice Cubers	W x D x H	Ice Storage Capacity	Ice Production*
CB249A	15.3" x 18" x 27.2"	20 lb	62 lb
CB425A	19.7" x 22.8" x 31.5"	55 lb	102 lb
CB674A	29.1" x 23.6" x 40.5"	88 lb	145 lb
Ice Flaker w/6" Adjustable Feet			
GB903A	19.7" x 26" x 31.5"	66 lb	200 lb

\*Based on 70°F air and 50°F water temperature in a 24 hr period

## Self-Contained Cubelet with Built-In Storage Bin

- Self-contained, undercounter design is less than 32" tall, which complies with the Americans with Disabilities Act (ADA)
- Air-cooled
- Durable stainless steel exterior
- Up to 22 lbs of built-in storage capacity
- Fewer moving parts for longer life
- Swing style reversible door
- R-134a refrigerant
- 14⅞"w x 22⅝"d x 31½"h
- 115V

C-80BAJ-AD 80 lb Ice Production\*

\*Based on 70°F air and 50°F water temperature in a 24 hr period



## X Series Ice Machines

- True square, 1¼" x 1¼" x 1¼" cubes
- LCD display
- Air cooled
- Stainless steel construction



GTX361AC  
Shown on bin,  
sold separately

**KOLD-DRAFT**

ice machines • bins • crushers • dispensers  
A Division of Legacy

	W x D x H	Ice Production*
GTX361AC	30.1" x 25.7" x 16.9"	352 lb
GBX561AC	42.3" x 31.1" x 17"	490 lb
GBX1064AC	42.3" x 25.7" x 33.7"	1075 lb

\*Based on 70°F air and 50°F water temperature in a 24 hr period



## Modular Ice Makers

- Stainless steel construction
- Produces half dice ice cubes
- Stackable
- Air cooled
- 3 year parts and on-site labor, 5 year compressor (part only) warranty



MIM615H  
Shown on bin,  
sold separately

**MAXX ICE**

A Division of Legacy

	W x D x H	Ice Production*
MIM475H	30" x 24" x 21"	475 lb
MIM615H	30" x 24" x 21"	615 lb
MIM915H	30" x 24" x 26.63"	915 lb

\*Based on 70°F air and 50°F water temperature in a 24 hr period

## Modular Crescent Cubers

- Durable stainless steel exterior
- Protected by H-GUARD Plus Antimicrobial Agent
- CycleSaver™ design - fewer cycles for less wear and tear
- EverCheck™ alert system - tells when unit needs service
- Storage bin sold separately
- R-404A refrigerant
- 3 year parts and labor on entire machine, 5 year parts and labor on evaporator, 5 year parts on compressor, air-cooled condenser coil



KML-500MAJ  
Shown on optional  
B-500 Bin

Ready to learn more about these great products?

**PLAY VIDEO**



	Ice Production*	Condenser	Height
<b>Slimline - 22"w x 27¾"d</b>			
KM-350MAJ	489 lb	Air-cooled	28"
KM-520MAJ	556 lb	Air-cooled	28"
KM-660MAJ	665 lb	Air-cooled	28"
KM-350MWJ	414 lb	Water-cooled	28"
KM-520MWJ	474 lb	Water-cooled	28"
KM-660MWJ	669 lb	Water-cooled	28"
KM-520MRJ	547 lb	Remote air-cooled	28"
KM-660MRJ	646 lb	Remote air-cooled	28"
<b>Low-Profile - 30"w x 27¾"d</b>			
KML-325MAJ	380 lb	Air-cooled	22"
KML-500MAJ	442 lb	Air-cooled	22"
KML-700MAJ	658 lb	Air-cooled	26"
KML-325MWJ	385 lb	Water-cooled	22"
KML-500MWJ	543 lb	Water-cooled	22"
KML-700MWJ	756 lb	Water-cooled	26"
KML-700MRJ	742 lb	Remote air-cooled	26"

\*Based on 70°F air and 50°F water temperature in a 24 hr period

## Self-Contained Ice Machine

- Air cooled
- True square, 1¼" x 1¼" x 1¼" cubes
- Front breathing inlet and discharge allows installation in tight spaces
- Corrosion-resistant stainless steel exterior with plastic door and bin liner
- Stores 125 lb of ice
- 26"w x 28.6"d x 37.4"h



SC201AC  
150 lb Ice Production

\*Based on 70°F air and 50°F water temperature in a 24 hr period

**KOLD-DRAFT**

ice machines • bins • crushers • dispensers  
A Division of Legacy



REFRIGERATION EQUIPMENT

# REFRIGERATION EQUIPMENT



## Countertop Water Dispenser

- Four water options: Chilled, Alkaline, Hot and Sparkling
- LED touch buttons
- Stainless steel body with black polycarbonate button panel
- Hot water safety switch and LED indicator
- Filter status LED indicator
- 10¼" cup clearance

Ready to learn more about these great products?

**PLAY VIDEO**



DWM-20A 20 gal/hour



## Soft Serve Machines

- For a variety of products including: soft serve, frozen yogurt, ice cream, custards and sorbets
- Independent digital control system automatically regulates and maintains consistent product quality
- Refrigerated hoppers with standby mode and agitation keep product fresh, even overnight
- Air-cooled



6220



	W x D x H	Hoppers	Volts	Flavors	4 oz Servings/hr
<b>Countertop</b>					
6220*	16¾" x 21½" x 27½"	(1) 8.5 qt	110-115	1	144
6235H*	21½" x 31½" x 35"	(2) 12.7 qt	208-230	2 + 1 Twist	400
6235AH^	21½" x 31½" x 35"	(2) 6 qt	208-230	2 + 1 Twist	400
6265H*	24¼" x 31½" x 41½"	(3) 8.5 qt	208-230	3 + 2 Twist	390
<b>Floor</b>					
6250AH^	21.8" x 25.8" x 58"	(2) 6 qt	208-230	2 + Twist	400
6378AH^	21" x 27.7" x 61.5"	(2) 7.5 qt	208-230	2 + Twist	624

\*Gravity feed dispensers ^Air pump pressurized dispensers



## Digital Modular Ice Makers

- Stainless steel construction
- Produces half dice ice cubes
- Stackable
- Air cooled
- Solid state digital controls
- 3 year parts and on-site labor, 5 year compressor (part only) warranty



MIM370H  
Shown on bin,  
sold separately



A Division of Legacy

	W x D x H	Ice Production*
MIM360NH	22" x 24.6" x 21"	361 lb
MIM370NH	30" x 24.6" x 21"	361 lb
MIM500NH	30" x 24.6" x 21"	513 lb
MIM650NH	30" x 24.6" x 21"	645 lb
MIM1000NH	30" x 24.6" x 26.7"	1005 lb

\*Based on 70°F air and 50°F water temperature in a 24 hour period



A Division of Legacy

## Self-Contained Ice Makers

- Stainless steel construction
- Produces half dice ice cubes
- Includes ice scoop
- Air cooled
- Programmable, solid state digital electronic control system
- 1 year parts and on-site labor, 5 year compressor warranty (MIM265H has 3 years parts & labor; 5 year compressor warranty)



MIM85H



	W x D x H	Ice Storage Capacity	Ice Production*
MIM85H	16.5" x 21.375" x 32.5"	25 lb	88 lb
MIM125H	22.125" x 21.375" x 32.5"	35 lb	125 lb
MIM265H	24" x 24" x 39"	75 lb	265 lb

\*Based on 70°F air and 50°F water temperature in a 24 hour period

## Electric Range

- Stainless steel front, sides, backguard, landing ledge and kick plate
- 1 chrome rack and splatter screen
- Infinite heat controls
- Porcelainized oven interior
- 6" legs, adjustable feet
- 36" wide
- 208V

# IMPERIAL

IR-6-E      6 Round Elements,  
1 Standard Oven



IR-10     



Shown with optional casters



EQUIPMENT

## Gas Ranges

- Stainless steel front and sides
- Stainless steel backguard and high shelf
- Removable heavy-duty oven door
- Porcelainized oven interior
- 5" stainless steel landing ledge
- Cast iron top grate - 12" x 12" sections
- 100% safety oven pilot
- 1 chrome plated rack per standard oven
- 1 year parts and labor limited warranty

	Burners	Oven	Width	BTU
IR-6	6	1	36"	227,000
IR-10	10	2	60"	350,000

## Black Diamond Gas Ranges

- Stainless steel front, backriser and shelf
- 12" x 12" cast iron removable top grates
- 3/4" thick polished steel griddle plate (ranges with griddles listed below)
- 150° to 550°F temperature range
- Steel liner on door and sides with a porcelain oven liner
- Includes 2 removable and adjustable oven racks

	Width	Burners	Oven(s)	Griddle/Broiler	BTU
BDGR-24/NG	24"	4	1	-	150,000
BDGR-36/NG	36"	6	1	-	210,000
BDGR-60/NG	60"	10	2	-	360,000
BDGR-3624G/NG	36"	2	1	24" Griddle	130,000
BDGR-6024G/NG	60"	6	2	24" Griddle	276,000
BDGR-6024GB/NG	60"	6	2	24" Griddle/Broiler	280,000

BDGR-3624G/NG



# EQUIPMENT



P36A-BBB  
Shown on  
optional  
casters



## Platinum Heavy-Duty Gas Ranges

- Stainless steel front, sides, rear, exterior bottom and 6" adjustable legs
- 36" wide
- Manual controls
- 45,000 BTU oven with standing pilot and thermostat range of 175° to 550°F
- 3 year limited parts and labor warranty

### Standard Oven Base

#### Combination Tops, 24" Griddle

- P36D-GGC 12" Charbroiler
- P36D-BTT (2) 33,000 BTU Burners
- Full-Width Griddle
- P36D-GGG 36" Griddle

### Convection Oven Base

- P36A-BBB (6) 35,000 BTU Burners



4601DD



## 400 Ultimate Series Ranges

- Standard or wavy cast iron grates
- Heavy-duty counter balanced oven door
- Manual gas shut off valve for entire range
- Metal knobs
- 45,000 BTU standard oven base (NAT)
- High efficiency snap action oven thermostat
- Choice of electric oven base with gas top (Hybrid)
- All enameled covered oven with lift-out bottom
- Stainless steel construction
- Factory installed regulator
- Standard 22½" flue riser with heavy-duty shelf
- Optional spark ignition and flame failure
- 1 year limited parts and warranty

	Width	Burners	Oven(s)	Griddle
4241E	24"	4	1 Space Saver	-
4361D	36"	6	1 Standard	-
4481EE	48"	8	2 Space Saver	-
4481EE-2GL	48"	4	2 Space Saver	24", Left
4601DD	60"	10	2 Standard	-
4601DD-3GL	60"	4	2 Standard	36", Left

Fully Customizable – Choose Your Burners and Grates. Many other configurations available, contact your local sales representative for details.

## S Series Restaurant Ranges

- Patented 28,000 BTU clog-free burners
- 35,000 BTU standard oven
- Stainless steel front rail with closed, welded end caps
- Black enamel oven interior
- Chrome knobs and door handle
- U burner and snap action thermostat
- 24/7 warranty

	Width	Burners	Oven(s)	Griddle
S36D	36"	6	1 Standard	-
S48EE	48"	8	2 Space Saver	-
S48EE-2GR	48"	4	2 Space Saver	24", Right
S60DD	60"	10	2 Standard	-
S60DD-3GR	60"	4	2 Standard	36", Right

Fully Customizable – Choose Your Burners and Grates. Many other configurations available, contact your local sales representative for details.

S60DD



## Platinum 32 - The Standard in Sectional Equipment Batteries

Southbend sectional batteries are designed to withstand the rigors of high-volume restaurants, hotel kitchens and institutional kitchens. Heavy-duty ranges, griddles, charbroilers, stock pot ranges, fryers and broilers can be combined for a 100% custom line-up to fit the needs of any high-volume operation.

Four 20,000 BTU burners with Hi/Lo setting and removable steel plate with 700°F surface temperature

Choice of three shelves:  
– Solid – Tray – Tubular  
(available in single or double)

80,000 BTU Charbroiler with removable cast iron grates and uniform cooking surface up to 600°F can be mounted on any base. Field convertible from cast iron radiants to lava rocks



EQUIPMENT

Front and Rear gas connection – standard

Stainless steel cabinet base with dual side-by-side removable doors and optional shelf

Continuous 9" front rail standard – optional 7¼" front rail with square belly bar



**Free Battery Design Assistance**

### Features and Specifications

- Largest variety of sizes to choose from: 12", 16", 24", 32", 36" and 48"
- Ranges can be mounted on cabinet, standard or convection oven, refrigerated base or TruVection base
- Heavy, solid stainless steel removable shelf standard with shelf risers
- FRONT and REAR gas connections
- Standing oven pilot ignition on standard and convection oven bases
- Porcelain oven interior standard, optional stainless steel interior
- Heavy-duty cast iron split grates, flush top design
- 45,000 BTU standard and convection oven bases
- 45,000 BTU PyroMax cast iron open burners
- Deepest standard oven capacity
- Cool-to-the-touch door handle
- Stainless steel front
- Stainless steel front and sides on flue riser
- Stainless steel base, sides and burner box standard

### Warranty

- 2 year warranty on operational parts, 1 year labor 24/7 warranty
- Lifetime warranty on burners against clogging
- Lifetime warranty on legs

### Options & Accessories

- Electronic oven pilot ignition available (must be specified)
- Spreader cabinets
- Flue risers w/shelves
- Extra deep 42" model
- Stainless steel work top
- Belly bar
- Pressure regulators
- Stainless steel rear
- Stainless steel enclosures under shelves or broilers
- Continuous front rails
- Overlapping griddle
- Extra oven racks
- Heavy-duty casters
- Caster frames

24/7 warranty is effective on all Southbend Equipment.

# EQUIPMENT

## Platinum Series Infrared Cheesemelters

- Stainless steel construction
- Dual valve controls
- 90 second preheat time with no waiting between loads
- 10,000 BTU infrared burners
- Removable crumb tray
- 5 position rack

- Standard mount on the flue riser of a sectional and/or restaurant range
- 3 year limited parts and labor warranty



P24-CM 2 Burners, 24" wide  
 P32-CM 4 Burners, 32" wide  
 P36-CM 4 Burners, 36" wide

P48-CM 6 Burners, 48" wide  
 P60-CM 6 Burners, 60" wide  
 P72-CM 8 Burners, 72" wide

## Broiler Salamanders

- Stainless steel construction including radiants
- Dual valve controls
- 5 position, "Easy Track", counter balanced, rack adjustment
- Cool touch handle design
- Flue riser mount standard
- Chrome plated cooking grates
- Burners run front to back for better zone control
- 10,000 BTU infrared burners
- 2 year limited parts and labor warranty

### Radiant

P36-RAD 4 Burners, 36" wide  
 P48-RAD 6 Burners, 48" wide

### Infrared

P36-NFR 4 Burners, 36" wide  
 P48-NFR 6 Burners, 48" wide



P36-NFR



## Gas Radiant Charbroiler

- Stainless steel front and sides
- (6) 15,000 BTU burners
- Removable reinforced cast iron radiants
- Cast-in grease trough
- 1 year parts and labor warranty

IRB-36 36"w x 29 1/4"d



## Infrared Salamander Broiler

- Four position adjustable grid with individual left and right gas controls
- Stainless steel front, sides and top
- Infrared burner with a protective screen
- Rack assembly raises, lowers and extends forward for loading and unloading
- 35,000 BTU

ISB-36 36"w x 17 1/4"d x 17 1/4"h



# IMPERIAL



76-1150



## Add-On Griddle Tops

- For gas ranges only
- Converts existing range tops into a griddle
- Removable stainless steel grease tray included
- Lift handle provided
- Griddle surface is 7 gauge steel
- Base is heavy-duty angle iron construction
- 27"l x 3"h

76-1150 Covers 2 Burners, 12"w  
 76-1151 Covers 4 Burners, 24"w



76-1145

## Deluxe Portable Griddle Tops



- For use on commercial range gas burners, open fires, outdoor grills
- Stores in oven
- 3/16" steel
- With heat-resistant handles
- 22 3/16" long

76-1152 Covers 2 Burners, 10 3/16"w  
 76-1145 Covers 4 Burners, 22 3/16"w



76-1155

## Portable Griddle Tops

- Works equally well on gas, electric, or induction range (may scratch glass tops)
- Stores in oven
- 7 gauge steel
- 23" long



76-1147 Covers 2 Burners, 14"w  
 76-1155 Covers 4 Burners, 23"w







## Hydrovection™ Ovens

- Unites convection cooking with humidity for faster results and 20% greater yield
- Angle iron frame, stainless steel exterior and liner
- Easy access: dual pane, black glass dependent doors open simultaneously with one hand
- Manual control with function selection for hot air, humidity and cool down, plus ability to store 100 recipes
- Hydroburst feature for shot of 100% humidity at any time during the cook cycle
- 4 speed auto reversing fan for gentle to high speed cooking
- Spray hose, sealed stainless liner, and floor drain
- Double stack overall height is only 63.6"
- 38" w x 48 7/16" d x 25 1/2" h, without legs or casters
- 25" legs for single units, or upgrade to the 36" stand with pan slides and storage shelf
- (5) 304 polished stainless steel oven racks

<b>Electric</b>	
HV-100E SGL	Single, 15kW
HV-100E DBL	Double, 30kW
<b>Gas</b>	
HV-100G SGL	Single, 60,000 BTU
HV-100G DBL	Double, 120,000 BTU



## Improve Overall Impressions

- Better flavors & moisture
- More even bake patterns
- Consistent color
- Better caramelization



Shown with optional accessories

## Full-Size Hydrovection Ovens with Helix Technology

- Stainless steel front, top, sides and back
- Simultaneous split door operation
- Touch screen control allows cooking with timer and core probe simultaneously
- Stainless steel interior liner
- Retractable hand shower
- Innovative new Helix Technology forces air into the oven cavity improving product quality while decreasing cooking time
- Each oven accepts (5) 18" x 26" full-size baking pans



HVH-100ESGL	Electric, 15kW
HVH-100GSGL	Gas, 60,000 BTU

## Why choose Hydrovection over convection oven?

- 30% Faster cook times
- 20% Greater yields
- Better results
- Less expensive
- Compact footprint
- Split door design



Bread on the left baked in Hydrovection with Helix Technology. Bread on the right baked in standard convection oven.



Muffin on the left baked in Hydrovection with Helix Technology. Muffin on the right baked in standard convection oven.

## Mini Electric Combi Oven w/Hoodini™ Ventless Hood

- Stainless steel interior and exterior
- Cool touch door
- Reversible 9 speed fan
- Easy to use touchscreen control - stores up to 500 recipe programs with 15 steps each
- Multiple cooking modes include hot air, CombiSmart, CombiOptima, retherm, steaming, low-temperature steaming, forced steaming, proofing and preheating
- USB port for data and recipe transfer
- Automatic humidity pulsing
- Internal core temperature probe
- Automated CombiWash

### Hoodini™ Ventless Hood

- Removes smoke, odor and moisture from the oven cavity
- Combines catalytic system with condensing system
- No filters to change
- No top clearance required
- Door is not on timed lock



BLCT-6E-H 20.2"w x 41.1"d x 45.6"h (with Hood)



## Half-Size Electric Convection Oven

- Stainless steel front, top, back and sides
- Dual-pane thermal glass window
- 4" stainless steel legs
- 30¼"w x 25½"d



CTB 208-220/240V



Shown on optional stand

## Half-Size Dual Flow Gas Convection Oven

- Stainless steel front, top, sides and back
- Thermal glass window in stainless steel door frames
- Dual flow gas system combines direct and indirect heat
- Solid state thermostat with temperature range of 200° to 500°F
- Five chrome-plated racks, nine rack positions per section
- 30¼"w x 25½"d x 35½"h

DFG-50 27,500 BTU



## Convection Oven Baking Tips

- Lower the temperature by 25°F
- Check food frequently toward the end of cooking
- Don't crowd the oven
- Use low-sided baking sheets and roasting pans

To learn more visit: [thekitchn.com](http://thekitchn.com)

## Full Size Gas Convection Ovens

- Full angle-iron frame
- Stainless steel front, top, and sides
- Solid state infinite control with digital timer
- 200° to 500°F temp. range
- Accepts (5) 18" x 26" standard full size pans
- 38 $\frac{1}{4}$ "w x 36 $\frac{7}{8}$ "d
- 2 year parts, 1 year labor, and 3 year limited oven door warranty

### Standard Depth

ZEPHAIRE-100-G-ES-SGL Single, 45,000 BTU  
 ZEPHAIRE-100-G-ES-DBL Double, 90,000 BTU

### Bakery Depth

ZEPHAIRE-200-G-ES-SGL Single, 50,000 BTU  
 ZEPHAIRE-200-G-ES-DBL Double, 100,000 BTU



**BLODGETT**

ZEPHAIRE-100-G-ES-SGL



BDO-100-G-ES-DBL

## Convection Ovens

- Full angle-iron frame
- Stainless steel front, top, and sides
- Dual pane thermal glass windows encased in stainless steel door frames
- Double-sided porcelainized baking compartment liner
- Solid state thermostat with temperature control range of 200° to 500°F
- Standard depth baking compartment accepts (5) 18" x 26" standard full size baking pans in left-to-right positions
- Adjustable stainless steel legs: 25" on single models, 6" on double models
- 2 year parts and 1 year labor warranty

Gas - 45,000 BTU/Deck  
 BDO-100-G-ES SGL Single  
 BDO-100-G-ES DBL Double

Electric - 11kW/Deck  
 BDO-100-E SGL Single  
 BDO-100-E DBL Double



## TruVection Low Profile Convection Ovens

- Stainless steel construction with coved, porcelain interior
- Patented, high efficiency, in shot burners
- Available in standard depth
- 36" w x 37 $\frac{1}{2}$ " d
- Dependent doors with windows
- Oven interior light
- Soft Air, two-speed, 1/2 hp fan motor
- 5-position rack guides and 3 plated oven racks, bottom rack is roller bearing
- Electronic ignition
- Cool down fan mode
- Oven "ready" light
- 6" stainless steel legs
- Can stack up to 3 units or modular equipment can sit on single deck
- 24/7 warranty

Gas - 52,000 BTU/Deck  
 TVGS/12SC Single, 26 $\frac{1}{4}$ "h  
 TVGS/22SC Double, 47 $\frac{3}{8}$ "h  
 TVGS/32SC Triple, 69 $\frac{1}{8}$ "h

Electric - 7.5kW/Deck  
 TVES/10SC Single, 26 $\frac{1}{4}$ "h  
 TVES/20SC Double, 47 $\frac{3}{8}$ "h  
 TVES/30SC Triple, 69 $\frac{1}{8}$ "h



TVGS/12SC



## B-Series Gas Convection Ovens

- Single - 55" standard height
- 54,000 BTU per deck
- Unibody construction
- "Plug and Play" controls
- Front serviceable
- Two stage dependent door sealing system with windows
- Electronic ignition and flame failure safety device
- 38" wide
- 1 year parts and labor warranty

BGS/12SC Single Deck, 35¾"d x 55"h  
 BGS/22SC Double Deck, 37¼"d x 66¾"h  
 Stacking Kit Includes 6" S/S Legs (Specify Unit)



BGS/12SC  
Shown with optional casters



SLGS/22SC  
Shown with optional casters



## SL Series Gas Convection Ovens

- Stainless steel front, top and sides
- 72,000 BTU per deck
- Unibody construction
- Standard depth
- "Plug and Play" controls
- Interior light (standard)
- Fully welded door frames
- Front serviceable
- Two stage dependent door sealing system w/windows
- Patented in shot burners
- Hot surface ignition system
- Electric models also available
- 2 year parts and labor warranty

Single - 38½"d x 57"h  
 SLGS/12SC Standard  
 SLGS/12CCH Cycle, Cook & Hold

Double - 30"d x 65"h  
 SLGS/22SC Standard  
 SLGS/22CCH Cycle, Cook & Hold



GS/15SC  
Shown with optional casters



## G-Series Gas Convection Ovens

- Stainless steel front, top and sides
- Single - 55" standard height/ Double - 64" standard height
- 90,000 BTU per deck
- Standard depth
- Unibody construction
- "Plug and Play" controls
- Fully welded door frames
- Front serviceable
- Two stage dependent door sealing system with windows
- Patented Jet Stream burners
- Interior lights (standard)
- 38" wide
- 3 year parts and labor warranty

Single - 37"d x 55"h  
 GS/15SC Standard  
 GS/15CCH Cycle, Cook & Hold

Double - 35¾"d x 64"h  
 GS/25SC Standard  
 GS/25CCH Cycle, Cook & Hold

## Half-Size Double Convection Oven

- Stainless steel front, sides, doors, top & legs
- Manual controls
- 2-speed fan motor
- Hinged doors w/windows
- 4 racks per deck
- Interior lights
- ½ hp per oven



HSICVE-2 30"w x 30"d x 62"h

**IMPERIAL**



Shown with optional stand and casters

## Provection Electric Oven

- Stainless steel exterior with porcelain interior
- Highly sensitive Ametek thermostat control system
- 3 racks, 5 rack positions
- Dependent doors with tempered glass windows
- Cool down feature
- ½ hp 2-speed fan motor

PVE-1 39"w x 42"d x 24"h

## Convection Ovens

- Electronic temperature control
- 150° to 550°F temperature range
- Stainless steel front, top, sides, doors and door seals
- Double-pane, thermal glass door windows
- Interior oven light
- 60-minute, continuous-ring timer
- Two-speed, ¼ hp fan motor with cool-down mode and low-speed setting (900 rpm)
- Porcelain enamel oven interior
- Eleven-position removable rack guides with 1.62" spacing
- Five heavy-duty, chrome-plated wire racks with stop
- Black powder-coated legs with adjustable bullet feet
- Front-mounted, hinged control panel
- 41.93"d



GDCO-E1  
Shown with optional casters



GDCO-E2  
Shown with optional casters

### Independent Doors

Electric—208/220/240V

BCO-E1

Single

BCO-E2

Double

Gas—60,000 BTU/Oven

BCO-G1

Single

BCO-G2

Double

### Synchronized Doors

GDCO-E1

W x H  
38½" x 58¼"

GDCO-E2

38½" x 62"

GDCO-G1

39" x 63¾"

GDCO-G2

39" x 72¼"

# EQUIPMENT



## Circle Air Oven

- Intuitive programmable touchscreen control
- Rotating rack system
- Door switch cutoff for fan blower
- Unique pulse and shot steam
- Dependent doors for single hand operation
- Advanced moisture evacuation system
- Jet air exclusive patented reversing fan system
- Stackable up to two ovens
- Holds 12 half size sheet pans
- 43 $\frac{1}{8}$ "w x 38"h
- 2 year parts and 1 year labor warranty



Shown on optional stand

CA6X Electric, 13.5 kW  
CA6XG Gas, 75,000 BTU



ATCO-513B-1  
Shown with optional casters

## Bakery Depth Gas Convection Ovens

- Stainless steel exterior and enamel interior with coved corners
- 50/50 dependent doors with double pane thermal tempered glass
- Accepts (5) 18" x 26" standard full-size baking pans
- Solid state digital controller with Cook 'n' Hold feature
- Temperature ranges from 150° to 500°F
- Interior oven light standard
- Features broil function and steam injection for humidity control
- Electronic spark ignition with an automatic pilot system with safety shut off
- 38 $\frac{1}{8}$ "w x 48 $\frac{3}{8}$ "d
- 1 year parts and labor warranty

Single Deck	Height	Shelves	Rack Guides	BTU
ATCO-513B-1	59 $\frac{3}{8}$ "	5	13	46,000
Double Deck				
ATCO-513B-2	69"	10	26	92,000



## Jet Air PIZ Series Pizza Ovens

- Stainless steel inside and outside
- Bakes pizza in 5-6 minutes
- Jet air convection reduces energy costs
- Heavy-duty doors with full view thermos glass
- Triple deck - large baking capacity
- $\frac{3}{4}$  hp motor
- 1 year parts and labor limited warranty



Electric	Dimensions	Capacity	
PIZ3	35 $\frac{7}{8}$ "w x 40 $\frac{1}{2}$ "d x 34 $\frac{1}{4}$ "h	(3) 18" Pizzas	8.2 kW
PIZ6	47 $\frac{5}{8}$ "w x 44 $\frac{7}{8}$ "d x 36 $\frac{1}{4}$ "h	(6) 18" Pizzas	13.5 kW
Gas			
PIZ3G	35 $\frac{7}{8}$ "w x 45 $\frac{1}{4}$ "d x 34 $\frac{1}{4}$ "h	(3) 18" Pizzas	70,000 BTU
PIZ6G	47 $\frac{5}{8}$ "w x 47"d x 36 $\frac{1}{4}$ "h	(6) 18" Pizzas	70,000 BTU

PIZ3  
Shown on optional stand

## Trio Ventless Rotating Pizza Oven

- Stainless steel construction
- Programmable touchscreen control
- Full view glass door with full illumination
- Easy open and close drop down door
- Bakes pizza in as little as 5 minutes
- Holds (3) 18" pizzas
- Ventless convection baking, hood not required
- Jet air exclusive reversing fan system
- Temperature up to 600°F
- Direct baking on nickel coated perforated decks (helps with heat retention)
- Designed for fresh or par-baked doughs
- 22" w x 14" d door opening
- 19" bake area on each nickel plated deck
- 208-240V
- 1 year labor and 2 year parts warranty

RPO3  
27 $\frac{1}{2}$ "w x 34"d x 28 $\frac{1}{2}$ "h





### Oven/Proofers

- Stainless steel construction
- Dual pane cool-to-the-touch oven door
- Touch screen programmable control
- Wi-Fi capabilities
- Best-in-class airflow system
- Fully insulated
- Magnetic handles
- AUTOMIST® Proofer
- Removable drip trough
- 12 Volt Halogen lights
- 208V-240V

QBT-3/9 NSF ETL Intertek

Dimensions 18" x 26" Pan Oven/Proofer

QBT-3/9	38½"w x 28½"d x 77¾"h
QBT-4/8	32¼"w x 37"d x 77¾"h
QBT-5/10	32¼"w x 37"d x 83¾"h

3/9
4/8
5/10



RSRE5 ETL Intertek ETL Intertek

### Rotating Rack Bakery Ovens

- Combine the efficiency of a convection oven with the uniform results of a rotating rack
- Heat elements are in direct contact with the baking chamber making space and heat exchange optimized so that less energy is consumed
- Available in gas or electric
- 1 year, on-site parts and labor warranty
- 220V



Capacity L x D x H

RSRE5	Single Rack	(15) 18" x 26" Trays	45¼" x 68" x 91¼"
RDRE11	Double Rack	(18) 26" x 36" Trays	57" x 79" x 102"



### Gas-Fired Manual Tilting Skillet

- 304 stainless seam welded pan body
- Pan rotates past 90°
- Adjustable thermostat from 175° to 400°F
- Electronic direct spark ignition
- Lid has full width condensate drip shield
- 120,000 BTU natural/100,000 BTU LP

TGSE-2440-9 40 Gallon Capacity



### Insulated Self-Contained Stationary Gas Kettle

- Stainless steel construction
- ¾ jacketed
- Seamless, deep-drawn liner with radius lip
- Thermostat control from 150° to 260°F
- Electronic ignition
- 131,400 BTU natural/131,000 BTU LP

LGB-80 80 Gallon Capacity



EQUIPMENT



## Convection Steamers

- Satin finished stainless steel construction
- Removable stainless steel pan supports
- Manual fill, manual drain
- Electric boiler free
- 60 minute electric timer
- 4" adjustable legs



	Pan Capacity	Height
18" w x 29" d		
EPXN-3	3	23"
EPXN-5	5	29½"
24" w x 25" d		
EPX-3	3	23"
EPX-5	5	29½"



EPX-3



EPX-5  
Shown on  
optional stand

## Steamed Up

Steam cooking retains the flavor, freshness, nutrients and texture that makes food appetizing. Excellent for cooking multiple types of food at once, convection steamers won't transfer taste from one food to the other.

Convection steamers are often preferable for heating frozen foods; the steam cooks the inside but is gentle enough to prevent burning the outside of the food.

To learn more visit: [Blodgett.com/steamers](http://Blodgett.com/steamers)



## Countertop Convection Steamers

- 1 compartment
- Electromechanical timer
- Three way power switch (on/off/delime)
- Automatic fill & drain operation
- Automatic generator blow down valve stainless steel interior, exterior
- 4" adjustable legs

Gas	Pan Capacity	Output
SX-5G3	3	42,000 BTU
Electric		
SX-3	3	208V/7.5kW
SXN-4	4	208V/7.5kW
SX-5	5	208V/15kW



SX-5G3



## Water Treatment Systems

- Neutralizes scale and reduces chlorine up to 99%
- 5 micron filtration
- Easy cartridge change out
- Quick disconnect fittings
- 6 month cartridge life
- Made in USA



1190861

- 1190861 For Single Steamer
- 1190862 For Double Stacked Steamer



## Insulated Heater/Proofer

- Heavy-duty aluminum construction
- Forced air design provides even heat distribution
- Easy dual proof/heat control
- Proof/Humidity mode: up to 95% humidity at 110°F
- Heat mode: maximum temperatures up to 180°F
- Door lifts off for easy cleaning and accessibility
- Easy to read LED thermometer
- 5" polyurethane plate casters, 2 locking
- Holds 18" x 26" pans
- 21½" w x 32" d x 66¾" h

INHPL-1836C-DGT

35 Pan Capacity



EQUIPMENT



Ready to learn more about these great products?

PLAY VIDEO



## Non-Insulated Heater/Proofer with Universal Runner

- Heavy-duty aluminum construction
- Forced air design provides even heat distribution
- Door gasket prevents heat loss
- Magnetic door latch
- Easy to read LED thermometer
- Proof/Humidity mode: Up to 95% humidity at 110°F
- Heat mode: maximum temperatures up to 180°F
- Drip trough catches condensation
- 5" polyurethane plate casters, 2 locking
- Digital power drawer
- Holds 18" x 26" pans
- 24" w x 32" d x 70" h

NHPL-1825-UNC-DGT

28 Pan Capacity



## Non-Insulated Heater/Proofer Cabinets

- Heavy-duty aluminum construction
- Forced air design provides even heat distribution
- Proof/Humidity mode: up to 95% humidity at 110°F
- Heat mode: maximum temperatures up to 180°F
- Door lifts off for easy cleaning and accessibility
- All controls are accessible without opening cabinet door
- Easy to read LED thermometer
- 5" polyurethane plate casters, 2 locking
- Holds 18" x 26" pans on 1½" spacing
- DGT models have digital power drawer

Standard Models	Pan Capacity	L x D x H
NHPL-1810/HHC	10	21" x 30¾" x 30¾"
NHPL-1836C-DGT	35	21" x 30¾" x 66½"
<b>Economy Model</b>		
NHPL-1836-ECOC	35	21" x 30¾" x 66½"
<b>Dutch Door Economy Model</b>		
NHPL-1833-ECOC-2D-DGT	33	20½" x 32½" x 66½"
<b>Knock Down Model</b>		
NHPL-1834-KD-E	34	21¼" x 30¾" x 67½"



NHPL-1836-ECOC



Ready to learn more about these great products?

PLAY VIDEO



# EQUIPMENT



## hotLOGIX Aluminum Heated Cabinets

- Bottom-mounted removable heating unit (models with humidity also have water reservoir)
- Recessed manual dial controls for temperature settings
- Single-pane tempered glass door set in extruded aluminum frame
- Cabinets come with fixed universal wire slides



Lightweight sturdy aluminum construction

29½"d x 24⅞"w Non-Insulated	31½"d x 26½"w Insulated	Type	18" x 26" Pan Capacity	Height
HL1-5	HL3-5	Holding	5	31⅞"
HL1-8	HL3-8	Holding	8	40⅞"
HL1-14	HL3-14	Holding	14	58⅞"
HL1-18	HL3-18	Holding	18	70⅞"
HL2-5	HL4-5	Holding & Proofing	5	31⅞"
HL2-8	HL4-8	Holding & Proofing	8	40⅞"
HL2-14	HL4-14	Holding & Proofing	14	58⅞"
HL2-18	HL4-18	Holding & Proofing	18	70⅞"



## Modular Hot Holding Cabinets

- Ideal for moisture-sensitive items, such as hamburgers, chicken, vegetables, etc.
- Stainless steel construction
- Built-in covers for each pan seal in moisture and along with the bottom heat creates the ideal environment
- Controls can be programmed for up to six items per pan, with individual pan timers
- Fits 2½" deep pans
- 15⅞"d



MC223GS-2T



	⅓ Size Pan Capacity	½ Size Pan Capacity	Full Size Pan Capacity	Configuration	W x H
MC213GS-2T	2	-	-	2 Cavities, 2 Controls, 2 Timers	9⅞" x 14½"
MC223GS-2T	4	2	-	2 Cavities, 2 Controls, 4 Timers	16¾" x 14½"
MC212GS-2T	6	2	2	2 Cavities, 2 Controls, 6 Timers	24⅜" x 12¾"
MC243GS-2T	8	4	2	2 Cavities, 2 Controls, 8 Timers	31¾" x 12¾"
MC423GS-2T	8	4	-	4 Cavities, 4 Controls, 8 Timers	24⅜" x 18½"



GC42



## GardenChef™ Herb & Micro Green Growing Cabinets

- Have fresh herbs or microgreens in as little as seven days, grown hydroponically or with traditional soil
- Touchscreen controls for setting up to 40 plant selections, watering and lighting cycles, and monitoring water quality for each growing zone
- All stainless steel construction
- Roll-out drawers for easy access and harvesting your greens; accommodate standard 10" x 20" growing flats and germination domes up to 7" high—full set included
- 3" casters and four adjustable leveling legs
- 28¼" deep

	Growing Zones	Growing Flat Capacity	Doors	W x H
GC11	1	2	1	37½" x 33¼"
GC12	2	4	2	66¾" x 33¼"
GC41	4	8	1	37½" x 79"
GC42	8	16	2	66¾" x 79"



## Heater/Proofer Cabinets

- Constructed of anodized aluminum extrusion
- Bottom heating and proofing modules are made from die formed aluminum and are easily removed for cleaning
- Controls are simple to operate
- Easy-to-read LED display
- Corner bumpers
- 5" swivel casters, two locking
- 22.83"l x 33.27"d

Half-Size, Insulated	Doors	Height	Rack Positions
HPIC-3414	Clear Polycarbonate	32.74"	14
HPIS-3414	Solid	32.74"	14

Half-Size, Non-Insulated	Doors	Height	Rack Positions
HPC-3414	Clear Polycarbonate	32.74"	14

Full-Size, Insulated	Doors	Height	Rack Positions
HPIDS-6834	Dutch Solid	67.64"	34
HPIC-6836	Clear Polycarbonate	67.64"	36
HPIS-6836	Full Solid	67.64"	36

Full-Size, Non-Insulated	Doors	Height	Rack Positions
HPC-6836	Clear Polycarbonate	67.64"	36



A Division of The Legacy Companies



HPC-6836



EQUIPMENT



ATHC-9

## Insulated Heater/Proofer/Holding Cabinets

- Stainless steel exterior and interior
- Heating mode with adjustable temperature settings
- 1.3" clearance between slides
- Proof mode has 10 adjustments for adjusting humidity level
- LED display
- Transparent clear polycarbonate door with 90° stay open feature
- Humidifying water tray to prevent loss of moisture and preserve food
- Fully insulated cabinet
- Detachable slides and removable control drawer
- Four casters – two locking, two swivel
- 25 1/10" x 30 7/10"

		18" x 26"	Pan Capacity	Height
ATHC-9	1/2 Size		9	42 7/10"
ATHC-18	Full Size		18	69 7/10"



## Transportable Gas Grills

- Aluminized steel construction with stainless steel front & 8" service shelf
- Modular design
- Heavy-duty chrome top grid
- Snap-in leg systems
- 6" heavy-duty casters
- Stainless steel radiants
- Separate burner/control every 7"
- Regulator/hoses and water tubs
- Stay-lit pilot system
- Removable tank cart system
- Tank safety and spark ignitor system

Propane: 40 lb Horizontal Tank(s) Included

LPAGA30-SS	30"w, 4 Burners, 30" Cooking Grid
LPAGA60-SS	60"w, 8 Burners, 60" Cooking Grid



LPAGA60-SS

**MagiKitch'n**



Grill - Roast - Steam - Griddle - Hold  
All Possible with Optional Accessories

# EQUIPMENT

## Solstice™ Fryers

- Stainless steel tank, front, door and sides
- High temperature safety switch
- 1½" full port drain valve
- 9" adjustable legs
- Removable basket hanger
- Drain line clean out rod
- Choice of 2 twin baskets or 1 full basket

### Electric Fryers

- Fixed heating elements for ENERGY STAR® performance
- Solid state thermostat
- 208, 220, 240V

### Gas Fryers

- Separate manual gas shutoffs
- Self cleaning burner and down draft protection
- Millivolt thermostat

Electric Gas

SE14S SG14S 40-50 lb Oil Capacity, 18" x 18" Fry Area, SG14S - 110,000 BTU

SE18S SG18S 70-90 lb Oil Capacity, 18" x 18" Fry Area, SG18S - 140,000 BTU



SE14S  
Shown with optional computer controls and casters

SG14S



## Tube Fired Gas Fryers

- Stainless steel tank, front, door, sides and splashback
- Two twin size baskets
- Solstice burner/baffle design
- Thermostat: 200° to 400°F
- 9" adjustable legs

VF-35S 15½"w x 32"d x 46⅞"h,  
35 lb Oil Capacity, 70,000 BTU

VF-65S 19¾"w x 34"d x 52⅞"h,  
65 lb Oil Capacity, 95,000 BTU



## Electric Fryer

- Stainless steel tank, front, door, sides, and splashback
- Two twin size baskets
- Electric thermostat maintains 200° to 375°F
- 6" adjustable legs
- 15½"w x 25"d x 41⅞"h

E35S 35 lb Oil Capacity



## Solstice Supreme™ Reduced Oil Volume Fryer with Filtration

- Offers 13% reduction in oil volume
- Lift assist system with 5 slot rack holder
- Tray hooks make loading/unloading racks easier
- Stainless steel tank and cabinet
- 1½" full port drain for fast draining
- Drain valve interlock
- 10 GPM filter pump
- 9" adjustable legs for leveling fryer
- 76 lb oil capacity



SFSELVRF Electric, 17kW  
SFSGLVRF Gas, 125,000 BTU



## MEGAFRY Fryer

- Stainless steel tank, front, door, sides and backsplash
- Solstice burner technology
- Solid state t-stat with melt cycle and boil out mode
- 1/4" full port drain valve
- Manual gas shutoffs and rear gas manifold connection
- 11" adjustable legs
- Drain line clean out rod and cleaning brush



SGM24 140-150 lb Oil Capacity, 165,000 BTU



## Tube Fired Gas Fryers

- Stainless steel tank, front and door
- Battery spark ignitor
- High temperature safety limit switch
- Built-in integrated flue deflector
- 1/4" full port drain valve
- Two twin fry baskets (regular mesh)
- Tube rack
- Removable basket hanger
- 6" adjustable legs



	Oil Capacity	BTU
35AS	40 to 45 lb	90,000
40AS	40 to 45 lb	107,000
45AS	40 to 45 lb	122,000
70AS	65 to 80 lb	150,000
<b>Anets Valve</b>		
40AV	35 to 40 lb	70,000
70AV	65 to 80 lb	95,000

## Standard Gas Fryer & Batteries

- S/S frypot with 10 year warranty
- Open vat design for easy cleaning
- 111,000 BTU input uses unique crossfire burners to cook like a 125,000 BTU fryer
- 4 sided heating system provides maximum recovery
- Fully insulated cabinet
- Extra large 1/2" full port ball drain valve
- 14" wide

14GS 35-50 lb Oil Capacity, 111,000 BTU



14GS



14GS-2FM

### Multiple Fryer Batteries w/Filter Mate System

- 14GS-2FM (2) 35-50 lb Oil Capacity Fryers
- 14GS-3FM (3) 35-50 lb Oil Capacity Fryers

# EQUIPMENT

## Black Diamond Gas Fryers

- 16 gauge stainless steel tank
- Cabinet is constructed with a stainless steel front and door with galvanized sides and back
- Thermostat range 200° to 400°F
- Includes two nickel-plated oblong wire mesh baskets
- Standing pilot light
- 6" adjustable legs
- 30¼"d x 53½"h
- Available in Natural (NG) or Propane (LPG) Gas

	Oil Capacity	Width	BTU
BDGF-90	35-40 lb	15½"	90,000
BDGF-120	45-50 lb	15½"	120,000
BDGF-150	65-70 lb	21"	150,000



BDGF-150

## GRINDMASTER



ATFS-50

## Cook Rite Gas Fryers

- Stainless steel construction
- Nickel plated wire baskets included
- High quality thermostat with temperature control from 200° to 400°F
- 4 casters
- 1 year parts and labor warranty and 5 year oil tank warranty



ATFS-40	40 lb Oil Capacity, 3 Burners, 102,000 BTU
ATFS-50	50 lb Oil Capacity, 4 Burners, 136,000 BTU



FMS403NAT

## Pro Series Gas Floor Fryers

- Heavy-duty stainless steel tank for long life and easy maintenance
- 6" adjustable legs
- Invensys® thermostat, 200° to 400°F
- 1¼" ball type full port drain
- Cool zone in fry tank
- Two nickel chrome wire mesh fry baskets included
- Available in Natural or Propane Gas
- 2 year parts and 1 year labor warranty

	Tank Size	Oil Capacity	BTU
FMS403NAT	14"w	40 lb	90,000
FMS504NAT	14"w	50 lb	120,000
FMS705NAT	19½"w	70 lb	150,000

## Fryers

- Stainless steel front, sides, door, basket hanger & frypot
- Snap action thermostat
- Includes: fine mesh crumb screen & 2 nickel-plated baskets
- 6" legs
- 14" x 14" frying area
- 15½"w

- Gas**
- Open pot
  - 140,000 BTU

- Electric**
- Immersed electrical elements
  - 208V-240V

Gas IFS-50-OP 50 lb Oil Capacity      Electric IFS-40-E 40 lb Oil Capacity



**IMPERIAL**



IFS-50-OP



IFS-40-E



## Pasta Cooker

- Stainless steel front, door, sides and tanks
- Tube fired burners
- Millivolt temperature control
- Water wash system

- 14" x 18" cooking area
- 1½" drain
- 6" casters
- 105,000 BTU

IPC-14  
12 gal Water Capacity



**PITCO**



## ANETS



GPC-14

### Pasta Pro Pasta Cookers

- Consistent and easy to use, this self-contained unit offers safety, efficiency and automatic features
- Perfect for pasta and all sorts of other boiling or reheating needs
- Submerge, boil, lift and drain the food with easy-to-manage baskets
- Adjustable continuous water fill
- Brings fresh water to a boil in less than 10 minutes
- Low temperature thermostat holds temperatures at an optimum 160°F
- 15½"w x 35½"d x 45½"h

GPC-14 7 gal Water Capacity, 111,000 BTU  
GPC-18 17 gal Water Capacity, 150,000 BTU



Prepares up to 190 servings of uncooked pasta per hour

### Gas Pasta Cooker & Rinse Station

- Stainless steel exterior cabinet & tank
- Complete self-contained work center requires less than seven feet of floor space
- Solstice burner technology, no blower or ceramics
- High efficiency design
- Self cleaning burner & down draft protection
- Digital controller with 4 button timer

SSPG14 12 gal Water Capacity, 14" x 18" Cooking Area



**EQUIPMENT**

# EQUIPMENT

## Gas & Electric Rethermalizers

- Stainless steel tank
- Cabinet polished stainless steel front, door & splash back
- Aluminized steel sides & back
- Automatic water fill with bypass switch
- Digital controller with timers
- Drain valve interlock
- Common drain outlet
- Adjustable 6" legs



**Gas**  
SRTG14 17½ gal Water Capacity, CGA

**Electric**  
SRTE14 16½ gal Water Capacity, UL



## Portable Fryer Filters

- Filter pan and pump assembly enclosure are constructed of polished stainless steel
- All other surfaces are nickel-plated finish
- Quick disconnect hose connections
- Easy to remove filter media assembly for quick and easy filter paper replacement
- Lift-out filter pan for easy cleaning
- Return hose nozzle is nickel-plated steel with a non-heat conducting handle
- Available for gas or electric

**P14** 55 lb Oil Capacity  
**P18** 75 lb Oil Capacity



## Fryer Baskets

- One-piece construction, non-welded structure
- Long lasting frame
- Nickel plated
- High-temperature resistant colored plastic handle

### Chimichanga/Burrito Fry Basket - 18/8 Stainless Steel

FB-03 11½" x 6" x 3⅞", 8" Handle

### Standard Baskets - Nickel Plated

- FB-05 11" x 5½" x 4¼", 10" Black Handle
- FB-10 12⅞" x 6½" x 5⅜", 10" Orange Handle
- FB-25 12⅞" x 6½" x 5¼", 10" Red Handle
- FB-20 13¼" x 5⅝" x 5⅝", 10" Blue Handle
- FB-30 13¼" x 6½" x 5⅝", 10" Green Handle
- FB-35 13⅜" x 9½" x 6", 10" Gray Handle
- FB-40 17" x 8¼" x 6", 12" Yellow Handle

### Basket Presses

- FB-PB Fits FB-30, Red Handle
- FB-PS Fits FB-10 & FB-20, Red Handle

### Basket Divider

- FB-DIV Fits FB-10, FB-25 & FB-30



FB-10



FB-03



FB-PS



FB-DIV





## The Basket Border™ Basket Dividers

- Converts a standard fryer basket into a multi-compartment basket
- Keeps different foods separate and helps maintain portion control
- Nickel plated

226-1132 Fits 5 5/8" w x 6 1/2" h Baskets  
 226-1146 Fits 6" w x 6 1/2" h Baskets  
 226-1147 Fits 5 5/8" w x 5 5/8" h Baskets

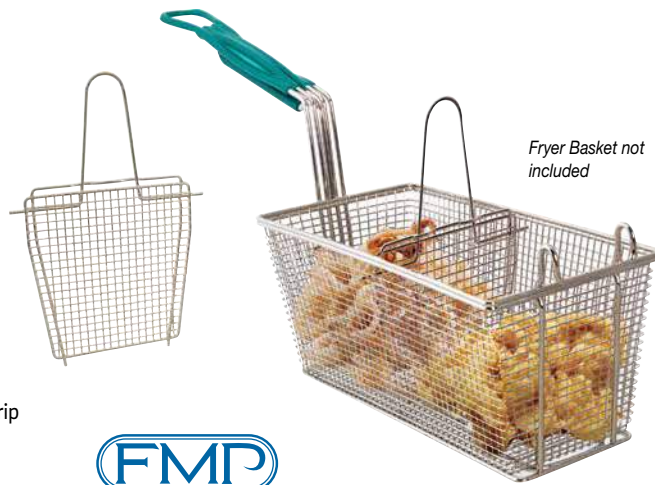

Fryer Basket not included

## E-Z Grip® & E-Z Grip® Plus Fryer Baskets

- Ergonomically designed to allow a "squeezing" action for a better grip when handling basket
- Nickel plated with teal vinyl-coated handle

### E-Z Grip® Plus Basket

- Patented corner protection and double front hook construction dramatically extends the life of the basket



## Standard Fryer Baskets

- Nickel plated
- Front hook



225-1026



225-1069



225-1041 4 1/4" x 13 1/4" x 5 1/2"  
 225-1000 5 5/8" x 11" x 4 1/8"  
 225-1010 5 3/4" x 13 1/4" x 5 3/4"  
 225-1062 6 5/16" x 12 7/8" x 5 5/16"  
 225-1001 6 1/2" x 12 7/8" x 5 3/8"  
 225-1060 6 1/2" x 13 1/4" x 6"  
 225-1002 8 1/4" x 17 1/8" x 6"  
 225-1003 12 1/4" x 13" x 5 5/8"

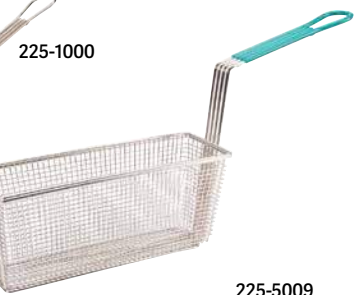

225-1000

225-5009  
**Fryer Baskets w/Teal Vinyl Handles**  
 225-5004 13 1/4" x 9 1/4" x 6"  
 225-5005 12 7/8" x 6 7/16" x 5 5/16"  
 225-5006 12 7/8" x 6 1/2" x 5 3/8"  
 225-5007 17 5/8" x 8 3/8" x 6"  
 225-5008 13 3/4" x 6 1/2" x 6"  
 225-5009 13 1/4" x 4 1/4" x 5 5/8"

### E-Z Grip® Baskets

225-1052 5 3/4" x 13 1/4" x 5 3/4"  
 225-1063 6 5/16" x 12 7/8" x 5 5/16"  
 225-1026 6 1/2" x 12 7/8" x 5 3/8"  
 225-1061 6 1/2" x 13 1/4" x 6"  
 225-1072 8 3/8" x 17 1/8" x 6"  
 225-1066 9 1/4" x 13 1/4" x 6"  
 225-1073 12 1/4" x 13" x 5 1/4"

### E-Z Grip® Plus Baskets

225-1071 5 3/4" x 17 1/8" x 6"  
 225-1070 6 1/2" x 13 1/4" x 6"  
 225-1069 6 1/2" x 12 7/8" x 5 3/8"  
 225-1100 8 3/8" x 17 1/8" x 6"

## Adjustable Height Plate Fryer Casters w/Brakes

- Adds up to 9 1/2" of total height
- Grease resistant, non-marking, polyurethane wheels with brakes
- 200 lb per wheel capacity
- Set of 4

FPCF353 3" Caster with 3 1/2" Square Plate

## Universal Square Plate Casters w/Brakes

- Multiple bolt holes to fit most food service equipment
- Grease-resistant, non-marking, polyurethane wheels with brakes
- Temperature range: 14° to 212°F
- Set of 4

250 lb/Caster Capacity  
 FPCST355 3 1/2" Square Plate  
 FPCST5 4" Square Plate

Heavy-Duty, 500 lb/Caster Capacity  
 FPCST5HD 4" Square Plate



FPCF355



FPCST355



FPCST5HD



## Universal Plate Casters w/Brakes

- Grease resistant wheels
- 250 lb load capacity per caster
- 5" wheel with brake
- Universal hole pattern fits most manufacturers
- High quality
- Set of 4

28-107S 4" Square Plate



## Ultra Low Profile Universal Plate Casters

- High quality wheel built for durability
- 200 lb load capacity per caster
- 1" wheel with brake
- Raises height 2"
- Fits most manufacturers
- Temperature range of 4° to 176°F
- Set of 4

28-109S 3 1/2" Square Plate





## Discover The Dormont Difference

- Proud to be an American manufacturer
- Over 70 years and 160 million safe connections
- Inventor of the Foodservice Gas Connector
- Only ISO-certified US manufacturer
- Every hose is 100% leak tested
- Exceeds ANSI & CSA standards



### Blue Hose® Gas Connector Kits

- All kits feature StressGuard® rotational fittings, stainless steel corrugated tubing, stainless steel braid, and an antimicrobial PVC coating
- Coil restraining device, full port gas ball valve and (2) 90° street elbows
- Meets the updated ANSI Z21.69 code
- Exclusive antimicrobial PVC dipped coating provides a smooth, plastic surface that will not peel, crack, wrinkle or hold a flame
- Swivel Max® increases the range of motion to enable easier movement of castered equipment from side-to-side, back and forth and angles
- SnapFast®, the only push-to-connect quick disconnect (QD) fitting designed for commercial kitchens, makes it easier and faster to service and move gas equipment for cleaning and maintenance, includes a thermal shut-off for added safety

3/4" x 48"

1675KIT48

Kit w/SnapFast® Quick-Disconnect

1675KITS48

Kit w/SnapFast® Quick-Disconnect & Swivel MAX®

1675KIT2S48

Kit w/SnapFast® Quick-Disconnect & 2 Swivel MAX®

1/2" x 48"

1650KIT48

Kit w/SnapFast®

1" x 48"

16100KIT48

Kit w/SnapFast®



### Swivel MAX® The Maximum Movement Swivel

- Provides full 360° multi-plane rotational device that significantly increases range of motion of Blue Hose and caster-mounted appliances
- Provides 360° range of motion
- Reduces stress on gas connectors
- Expands aisle space because gas equipment can be moved closer to walls
- Can be used on one or both ends of gas connector
- Replaces rigid street elbows in most installations

SM50

1/2"

SM75

3/4"

SM100

1"



### Snap'N Go®

The Snap'N Go® holsters the Blue Hose when disconnected during routine cleaning, maintenance or installation



### Safety Quik® Fitting

- Maximizes safety
- Quick Disconnect and valve that prevents disconnection while gas is flowing
- Valve handle cannot rotate to an open flow position while disconnected
- Includes internal thermal shutoff within temperature range of 250° to 300°F
- Sold separately and in Blue Hose Kits

CF50

1/2" Inner Diameter

CF75

3/4" Inner Diameter

CF100

1" Inner Diameter



### Safety-Set®

- Accommodates 3", 4", 5" and 6" casters
- Open-floor design allows appliance to rest level of the floor to ensure even cooking
- Ensures your caster-mounted kitchen equipment is returned to the precise position beneath ventilation and fire suppression systems
- Great for use with all caster-mounted equipment, salad carts and refrigerators
- Includes everything you need for fast, easy installation
- Satisfies NFPA codes 17A (5.6.4) and 96 (12.1.2.3)

PS

Withstands 1000 lb of Crush Force



## Heavy-Duty Gas Hoses

- Stainless steel corrugated tubing encased in stainless steel braid
- One-piece construction (no weld)
- Tough, flexible and corrosion-resistant
- Thick, non-toxic plastic coating
- Includes 1 gas male flare fitting and 1 gas female flare fitting
- Limited lifetime warranty

32-1637	1/2" x 48"
32-1639	3/4" x 36"
32-1634	3/4" x 48"
32-1635	3/4" x 60"
32-1633	1" x 48"



## Jet Force Gas Connector Kits

- Includes gas connector, quick disconnect, restraining device, ball valve, (2) 90° street elbows, 1 male flare fitting and 1 female flare fitting

32-1645	1/2" x 48"
32-1643	3/4" x 36"
32-1647	3/4" x 48"
32-1642	3/4" x 60"
32-1640	1" x 48"



EQUIPMENT

## Location is Key!

Caster chocks allow for equipment to be returned to its appropriate location, in relation to fire suppression and ventilation systems

To learn more visit: [krowne.com](http://krowne.com)

## Caster Positioning Set

- Includes 2 stainless steel chocks, 8 hex screws and 8 drop-in anchors

28-200



## The Ultimate Gas Connector Kits

- Complete Kit includes: Gas Connector, Quick Disconnect, Gas Valve, Restraining Kit, (2) 90° Elbows
- Ends rotate for simple installation and durability
- Stainless steel hose with antimicrobial PVC-coated protective layer
- Designed to be used with stationary and caster-mounted equipment
- Heavy-duty stainless steel corrugated tubing with stainless steel radial wrap
- Welded construction for added durability
- 3/4" interior diameter

Complete Kits	Length
M7536K	36"
M7548K	48"
M7560K	60"
M7572K	72"

Gas Valve Swivel Fitting  
SW75 3/4" dia



## Premium Baffle Grease Filters

- Safe, dependable, positive flame barrier protection
- Seamless, smooth surfaces permit constant grease run-off into hood collection troughs easily cleaned by soaking or spraying, or in conventional dishwasher
- 2" thick
- All sizes listed are nominal (not exact)

### Aluminum Filters

26-2262	16" x 16"
26-1758	16" x 20"
26-1759	16" x 25"
26-1760	20" x 16"
26-1761	20" x 20"
26-1762	20" x 25"
26-1763	25" x 16"

### Stainless Steel Filters

26-3885	16" x 16"
26-1773	16" x 20"
26-3895	16" x 25"
26-1774	20" x 16"
26-1775	20" x 20"

### Galvanized Filters

26-1766	16" x 20"
26-1769	20" x 20"
26-1770	20" x 25"
26-1771	25" x 16"



26-2262



26-3885

## Making the Impossible Possible

Our Universal Ventless Hoods give you the option to use almost any commercial electric cooking equipment such as ovens, fryers, ranges, griddles, hot plates, rethermalizers, woks, steamers, combi ovens, induction hot plates and more!

Finally, the flexibility to choose a wide variety of types and brands of electric cooking equipment!



Made in the USA



Ventless Hoods are a great alternative for areas that do not lend themselves to traditional hood installations. Whether for historic buildings or tight spaces, this self-contained system is a perfect solution for unique spaces.

### VCS 2000 Series System

- Offers the opportunity to "set up shop" in any well-ventilated room, with a wide variety of equipment to match any menu
- All-in-One — integrated ventless hood and cooking equipment in one, ready-to-use package
- 19 models to choose from



Made in the USA

Other options available, contact your local sales representative for details.

# CaptiveAire

One System. One Source.

- Kitchen Ventilation - Hoods, Controls, Fire Suppression, Hood Filtration, Pollution Control. Also Fans, Heaters, Ductwork, and HVAC
- The nation's leading manufacturer of commercial kitchen ventilation systems for over 40 years
- CaptiveAire leads the industry with innovative technologies, unmatched service, competitive pricing, and rapid lead times



## Paragon

CaptiveAire's Superior Dedicated Outdoor Air System (DOAS)

- CaptiveAire's ideal HVAC solution offering exceptional energy savings, unprecedented comfort and humidity control



EQUIPMENT

Please contact your local sales representative for details. 



KITCHEN VENTILATION



DUCTWORK



MAKEUP AIR



CONTROLS



FANS



HEATERS

## Hot Food Tables

- Heavy-duty stainless steel construction
- Fiberglass insulation between each compartment
- 1" thick, 8" wide white thermoplastic cutting board
- Stainless steel undershelf and legs
- 120V

	Wells	Width
HF-2E-120	2	31 <sup>3</sup> / <sub>16</sub> "
HF-3E-120	3	47 <sup>1</sup> / <sub>8</sub> "
HF-4E-120	4	62 <sup>7</sup> / <sub>16</sub> "
HF-5E-120	5	77 <sup>3</sup> / <sub>4</sub> "



HF-3E-120

Other models available, contact your local sales representative for details.



## Sleek Shields™

Goodbye to the days of loosening and tightening bolts on both sides. Simply release the chamber and turn from only one side. Front glass easily rotates to any position. Our patented Chamber Lock™ System lets you position front glass at 15° intervals.

This low profile design means less metal and more visible glass, making this the sleekest food shield yet.

- Patented design
- Powder coat colors available
- Cafeteria, self-service, stationary, and display models available
- Various sizes and configurations available, please contact your sales representative



## Stainless Steel Work Tables

### 300 Series

- Straight sided
- Heavy-duty 18 gauge welded stainless steel construction
- Stainless steel undershelf, legs with adjustable bullet feet
- Available with or without backsplash

24"d Tables		w/1½" Backsplash	
82427	24"w	81233	30"w
82439	36"w	81251	48"w
82451	48"w		
82475	72"w		
82499	96"w		



300 Series  
w/ Backsplash



30"d Tables		w/1½" Backsplash	
83021	18"w	81328	18"w
83039	36"w	81337	36"w
83052	48"w	81349	48"w
83063	60"w	81361	60"w
83075	72"w	81373	72"w
83087	84"w	81397	96"w
83099	96"w		



430 Series



- Galvanized undershelf, legs with adjustable bullet feet
- Available with or without backsplash
- 37" high



### 430 Series

- Straight sided
- 18 gauge welded stainless steel construction

24"d Tables		w/1½" Backsplash		30"d Tables		w/1½" Backsplash	
82424	24"w	82437	36"w	83018	18"w	83031	30"w
82430	30"w	82461	60"w	83030	30"w	83037	36"w
82436	36"w			83036	36"w	83049	48"w
82448	48"w			83048	48"w	83061	60"w
82460	60"w			83060	60"w	83073	72"w
82472	72"w			83072	72"w	83097	96"w
82484	84"w			83084	84"w		
82496	96"w			83096	96"w		

## Equipment Stands

- 430 stainless steel
- Welded 18 gauge top
- Galvanized undershelf, legs with adjustable bullet feet
- 30"d x 24"h

82312	12"w	82336	36"w
82315	15"w	82348	48"w
82318	18"w	82360	60"w
82324	24"w	82372	72"w
82330	30"w		



82312



81226



## Work Table Overshelves

- 430 stainless steel, 18 gauge top
- Stainless steel legs and socket
- Easily attaches to work tables (allen wrench and screws included)

### Single Tier

81249	48"w
81261	60"w
81297	96"w

### Double Tier

81226	24"w
81232	30"w
81238	36"w
81250	48"w
81262	60"w
81274	72"w
81298	96"w



EQUIPMENT



# EQUIPMENT

## Folding Tables

- Durable 18 gauge type 430 stainless steel
- Safety lock mechanism
- 30 3/8" table height

### Without Undershelf

ROY WTF 2460	24" x 60", 350 lb Capacity
ROY WTF 2472	24" x 72", 395 lb Capacity
ROY WTF 3060	30" x 60", 395 lb Capacity
ROY WTF 3072	30" x 72", 440 lb Capacity

### With Undershelf

ROY WTFS 2460	24" x 60", 350 lb Top/88 lb Undershelf Capacity
ROY WTFS 2472	24" x 72", 395 lb Top/110 lb Undershelf Capacity
ROY WTFS 3060	30" x 60", 395 lb Top/110 lb Undershelf Capacity
ROY WTFS 3072	30" x 72", 440 lb Top/130 lb Undershelf Capacity



ROY WTF 2460



← These stainless steel tables fold flat.



ROY WTFS 2460

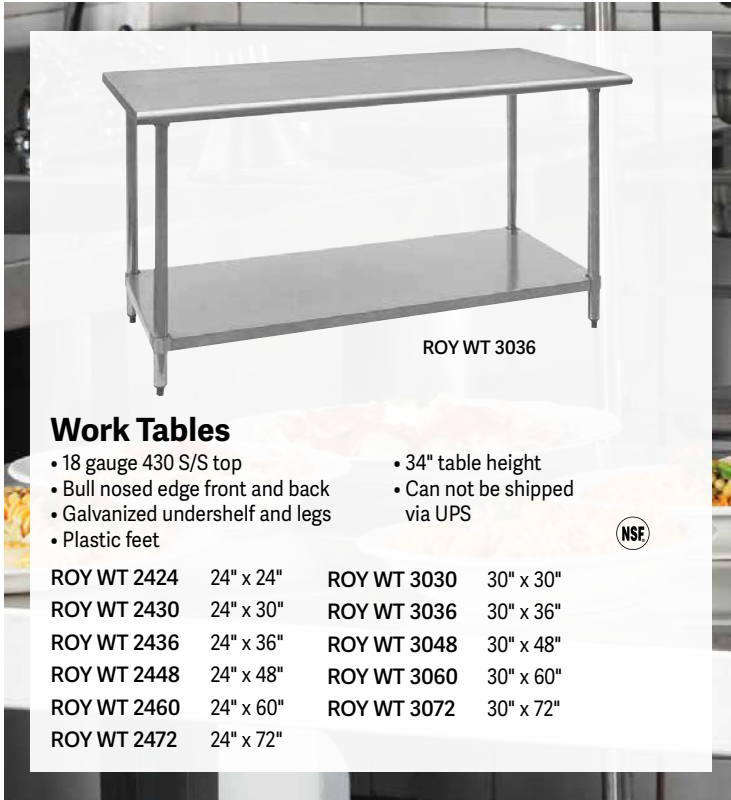

ROY WT 3036

## Work Tables

- 18 gauge 430 S/S top
- Bull nosed edge front and back
- Galvanized undershelf and legs
- Plastic feet
- 34" table height
- Can not be shipped via UPS



ROY WT 2424	24" x 24"	ROY WT 3030	30" x 30"
ROY WT 2430	24" x 30"	ROY WT 3036	30" x 36"
ROY WT 2436	24" x 36"	ROY WT 3048	30" x 48"
ROY WT 2448	24" x 48"	ROY WT 3060	30" x 60"
ROY WT 2460	24" x 60"	ROY WT 3072	30" x 72"
ROY WT 2472	24" x 72"		

## Equipment Stands

- 18 gauge 430 stainless steel top
- Galvanized legs and undershelf
- 30"d x 24"h

ROY ES 3024	24"w, 700 lb Capacity
ROY ES 3036	36"w, 800 lb Capacity
ROY ES 3048	48"w, 900 lb Capacity
ROY ES 3060*	60"w, 900 lb Capacity
ROY ES 3072*	72"w, 1000 lb Capacity

\*6 Legs



## Stem Casters

- Grease resistant wheels
- 5" wheel with brake
- Set of four

28-129S 220 lb Capacity Per Caster



## Expanding Stem Casters

- Grease resistant non-marking wheels
- 5" wheel with brake
- Set of four

FECST5B 300 lb Capacity Per Caster





## Maple Top Work Tables

- Stainless steel base
- 1 1/4" thick maple top with oil finish
- Adjustable bullet feet
- Shipped knocked down, easy-to-assemble

### Adjustable S/S Undershef

SNS08-X	48" x 30"	SNS10-X	72" x 30"
SNS09-X	60" x 30"	SNS11-X	96" x 30"

### Adjustable S/S Bracing

SNB08-X	48" x 30"	SNB14-X	48" x 36"
SNB09-X	60" x 30"	SNB15-X	60" x 36"
SNB10-X	72" x 30"	SNB16-X	72" x 36"
SNB11-X	96" x 30"	SNB17-X	96" x 36"



EQUIPMENT

## Maple Top Work Tables w/Riser

- Stainless steel base
- 4" covered riser
- 1 1/4" hard rock maple top finished with penetrating oil finish
- Adjustable bullet feet
- Shipped knocked-down, easy-to-assemble

### Adjustable S/S Undershef

DSS06-X	48" x 30"	DSS08-X	72" x 30"
DSS07-X	60" x 30"	DSS09-X	96" x 30"

### Adjustable S/S Bracing

DSB06-X	48" x 30"	DSB11-X	48" x 36"
DSB07-X	60" x 30"	DSB12-X	60" x 36"
DSB08-X	72" x 30"	DSB13-X	72" x 36"
DSB09-X	96" x 30"	DSB14-X	96" x 36"



# COUNTERTOP EQUIPMENT



## Twin Touch™ 4-Stage Commercial Microwaves

- 0.75 cu. ft. capacity fits
  - (2) ½ pans side-by-side or
  - (1) ½ pan in either direction
- Stainless steel interior and exterior
- Dual control panel design
- Unique durable squeeze trigger handle design minimizes door latch failure
- Rigid interior tempered glass door versus plastic film of competitors
- Top and bottom microwave energy feed
- Computerized control panels and select power
- Manual and memory programming
- 4 stage programming
- Double/triple quantity pads
- Express Defrost™ and counter check
- 17½" w x 13⅝" h x 20½" d
- Full 3 year parts and labor warranty on site

R-CD1200M 1200 watts  
 R-CD1800M 1800 watts  
 R-CD2200M 2200 watts

**SHARP**



## Dial 1-Stage Commercial Microwave

- 1.0 cu. ft. capacity, 1000 watts
- Medium duty
- Stainless steel interior and exterior
- 6-minute electronic lightup dial timer with auto-cancel
- Timer resets when door is opened during operation
- Unique durable squeeze trigger handle design minimizes door latch failure
- 1-stage cooking
- 120V
- 1 year parts and labor warranty

R21LCFS 20½" w x 16" d x 12⅝" h

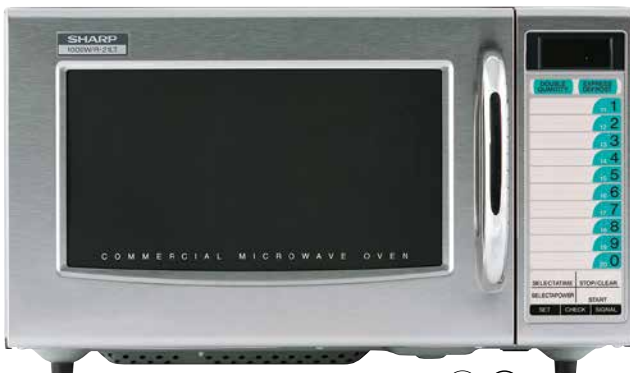

## Digital 3-Stage Commercial Microwave

- 1.0 cu. ft. capacity, 1000 watts
- Medium duty
- Stainless steel interior and exterior
- Computerized touch control
- 3-stage cooking
- 10 key / 20 memory touch pad
- Unique durable squeeze trigger handle design minimizes door latch failure
- Express Defrost™
- 120V
- 1 year parts and labor warranty

R-21LTF 20½" w x 16" d x 12⅝" h



## Digital 1-Stage Commercial Microwave

- 1.0 cu. ft. capacity, 1000 watts
- Medium duty
- Stainless steel interior and exterior
- Touch sensitive pads with braille
- 10 memory touch pad
- Unique durable squeeze trigger handle design minimizes door latch failure
- 1-stage cooking
- Express Defrost™
- 120V
- 1 year parts and labor warranty

R-21LVF 20½" w x 16" d x 12⅝" h



## Digital 3-Stage Commercial Microwaves

- Heavy-duty
- Stainless steel interior and exterior
- Top and bottom feed
- Double quantity pad
- 3-stage programming
- Unique durable squeeze trigger handle design minimizes door latch failure
- Express Defrost™
- SelectaPower™ and memory check
- Full 3 year parts and labor warranty on site

R-22GTF 1200 watts  
 R-25JTF 2100 watts

R-22GTF



### Dial Microwave

- Heavy-duty metal handle and durable interlock system
- Stainless steel body and cavity
- 1.0 cu ft
- Dial control
- LED display
- 20" w x 14" d x 12" h

GEW1000D 1000 watts



A Division of Legacy



### Digital Microwave

- Heavy-duty metal handle and durable interlock system
- Stainless steel body and cavity
- 1.0 cu ft
- Digital touch-pad controls
- LED display
- 3 stage cooking
- 10 power levels
- 20" w x 14" d x 12" h

GEW1000E 1000 watts



COUNTERTOP EQUIPMENT



TMW-1200HD



### Heavy-Duty Microwave Ovens

- Stainless steel exterior
- 0.9 cu ft
- Tempered glass door with interior light
- Clean air filter with convenient clean filter reminder
- 5 power levels and 3 stages heating option
- Double quantity pad (X2) increases a pre-programmed heating time for multiple servings of foods
- 14 touch control pads and easy-to-read VFD display
- Program up to 200 menu items for simple one-touch cooking
- 18 1/4" w x 23 1/2" d x 14 1/2" h
- 3 year parts and labor warranty

TMW-1200HD 1200 watts  
TMW-1800HD 1800 watts



TMW-1100NM



### Medium-Duty Microwave Ovens

- Stainless steel exterior
- 1000 watts
- 1.0 cu ft
- Tempered glass door with interior light
- Safety interlock system
- 21 1/8" w x 18 1/8" d x 13" h
- 1 year parts and labor warranty

TMW-1100NM

TMW-1100NE  
TMW-1100C

5 Power Settings, Time Defrost, Easy Grip and Commercial Door Handle Double Quantity Pad (X2), Includes Braille Keypad "One-Touch" Start & Stop Button, Heating Increments Of 30 Seconds

### Commercial Microwaves

- 1,000 watts of cooking power
- All stainless steel exterior and interior
- Motor driven bottom antenna for efficient energy distribution and consistent results
- Engineered for commercial kitchen use
- Stainless steel interior with bottom ceramic plate
- Ample 0.9 cu ft oven capacity
- Accommodates 12" diameter platter
- Backlit LED display
- Interior oven light
- 1 year warranty

EMW-1000SD Dial Controls w/Customizable Cooking Timer  
20.5" w x 17.9" d x 12.3" h

EMW-1000ST Touch Controls w/3 Customizable Key Beep Volume Levels  
20.1" w x 17" d x 12.2" h



EMW-1000ST



EMW-1000SD



# COUNTERTOP EQUIPMENT



PGT14



GX10IG



## Panini Grills

- Analog temperature controls with grooved or smooth plates
- Heavy-duty aluminum platens
- Heavy-duty commercial hinge system and handle
- The bottom platen has a patented splash guard
- Ergonomically designed control panel provides easy access and visibility to controls and grease drawer
- Top platen leveling system lifts top platen parallel to bottom platen for a full 3 inches before rotating up

## Grill Express™ Two-Sided Grills

- Heavy-duty, cast iron platens
- Thermostat rated from 175° to 450°F and provides accurate sensing of temperature
- Reliable hinge system provides effortless operation
- Removable grease trough
- Large heat resistant handle for safe operation
- 1 year warranty
- 120V

10.375" w x 23.3" d x 10" h

PGT7 Grooved  
PST7 Smooth

16.5" w x 23.3" d x 10" h

PGT14 Grooved  
PST14 Smooth

10" x 10" Cook Surface

GX10IG Grooved  
GX10IS Flat

14" x 10" Cook Surface

GX14IG Grooved  
GX14IS Flat



4 push-button electronic controls ensure heating consistency from sandwich to sandwich.

## PaniniPro™ High-Speed Sandwich Press

- Combines conduction and microwave technology to heat the protein and crisp the bread at the same time
- Spring-loaded upper plate ensures uniform plate-to-food contact
- Nonstick coating on all food-contact surfaces
- Pre-programmed with 8 standard heating cycles
- Includes flexible spatula
- 13½" w x 26½" d x 28½" h

208V

6900A-208-GF Grooved Top & Flat Bottom  
6900A-208-GG Grooved Top & Bottom  
6900A-208-FF Flat Top & Bottom

240V

6900A-240-GF Grooved Top & Flat Bottom  
6900A-240-GG Grooved Top & Bottom  
6900A-240-FF Flat Top & Bottom

Built-in USB port makes reprogramming for a menu change a simple process (flash drive with software included)



6900A-208-GF



**nemco** | FOOD EQUIPMENT

## Panini Grills

- Brushed stainless steel body construction and removable drip tray
- Hinged, auto-balancing top plate to suit foods up to 3" thick
- Adjustable thermostat to 570°F
- Power and Ready indicator lights
- Heat resistant handles
- Adjustable back feet for easy grease drainage
- Limited 1 year warranty



WPG250

### Compact Italian-Style Grills - 9 3/4" x 9 3/4" Cooking Surface

WPG150 Panini Perfetto™, 120V

WFG150 Tostato Perfetto™, 120V

### Large Italian-Style Grills - 14 1/2" x 11" Cooking Surface

WPG250 Panini Supremo™, 120V

WFG250 Tostato Supremo™, 120V

### Large Italian-Style Grill - 14" x 14" Cooking Surface

WFG275 Tostato Supremo™, 120V

### Dual Italian-Style Grills - 17" x 9 3/4" Cooking Surface

WPG300 Panini Ottimo™, 240V

WFG300 Tostato Ottimo™, 240V

### Compact Dual Surface Grills

WDG250 Panini Grill, 240V, 14 1/2" x 11" Cooking Surface

WDG300 Panini Grill, 240V, 17" x 9 3/4" Cooking Surface

WPG150/WPG250/WPG300 – Grooved cast iron plates for even heat distribution and quick cooking time

WFG150/WFG250/WFG275/WFG300 – Flat cast iron plates

WDG250 – Grooved top plate and flat bottom plate

WDG300 – Half-flat and half-ribbed plates

## Belgian Waffle Makers

- Heavy-duty die-cast housing
- Embedded heating elements for precise temperature control
- Rotary feature for even baking and browning
- Audio beep signals when waffle is ready
- Power and ready-to-bake LED indicators
- Nonstick plates allow for easy removal of waffle
- Single makes (25) 1 1/4" thick waffles an hour
- Double makes (50-60) 1 1/4" thick waffles an hour

WW180 Single, 120V

WW200 Double, Stacked, 120V

WW250 Double, Side by Side, 120V

WW250B Double, Side by Side, 208V



WW250



COUNTERTOP EQUIPMENT



PDR3000



## Sirman Panini Grills

- Stainless steel frame
- Ribbed cooking surface
- Grills constructed of non-stick cast iron for ease of use and clean up
- A grease tray and a special cleaning brush are included
- 110-220V (Double 220V only)

CORTR Single, 10" x 15"  
PDR3000 Double, 10" x 20"



## SinAqua™ Soupers

- Spun aluminum exterior construction and high-gloss polycarbonate fascia and tureen liner
- Includes one 18/8 stainless steel soup tureen and lid
- Precision hold and rethermalization functions
- Holding temperatures range from 140° to 200°F
- Rethermalizing temperatures range from 170° to 200°F
- Programmable stir notification
- Active dry-pan protection
- 100-120V, 800W

SAS081-7 7 qt

SAS081-11 11 qt



SAS081-7



# COUNTERTOP EQUIPMENT



6100A



## Countertop Cookers & Warmers

- Designed for versatility, improves flexibility and keeps food within cooking and serving guidelines
- Stainless steel construction - including wells - ensures durability and prevents pitting or staining
- Unique heating element design provides even distribution to prevent "hot spots"
- Compact, twin warmers have separate thermostats
- 120V

**nemco** | FOOD EQUIPMENT

### Countertop Warmers - 9 $\frac{7}{8}$ "h

6110A 4 qt, Single Well, 8 $\frac{7}{8}$ "w x 9 $\frac{3}{4}$ "d

6120A 4 qt, Twin Well, 18 $\frac{5}{8}$ "w x 10"d

### Round Warmers - 9 $\frac{5}{8}$ "h

6100A 7 qt, 10" dia

6101A 11 qt, 12 $\frac{1}{2}$ " dia

### Round Cooker/Warmers - 9 $\frac{5}{8}$ "h

6102A 7 qt, 10" dia

6103A 11 qt, 12 $\frac{1}{2}$ " dia

### Optional Inset, Cover & Ladle Sets

66088-2 4 qt Fits 6110A & 6120A

66088-8 7 qt Fits 6100A & 6102A

66088-10 11 qt Fits 6101A & 6103A

## Countertop Warmers

- Ideal for serving vegetables, stir-fry, casseroles, lasagna and other items in buffet lines and catering applications
- Reliable conduction type thermostat ensures that food held is always within the food safety temperature guidelines
- Unique heating element provides even heat distribution to prevent hot spots
- Heavy-duty stainless steel well
- Accepts a 12" x 20" full-pan or fractional-size pans
- 14 $\frac{3}{8}$ "w



6055A



- 6055A\* Full Size Warmer, 23 $\frac{1}{2}$ "d x 9"h, 120V
- 6055A-CW Full Size Cooker/Warmer, 23 $\frac{1}{2}$ "d x 10 $\frac{1}{2}$ "h, 120V
- 6055A-220 Full Size Warmer, Export, 23 $\frac{1}{8}$ "d x 9"h, 220V

\* Also CE



## Heat Lamps

- Adjustable height
- 250 watts per bulb
- White infrared bulb(s) included
- Pans not included
- 14"w x 19 $\frac{1}{2}$ "d x 24"h
- 120V

6000A-2B

Shown with optional base tray and pan

6000A-1

6000A-2

6000A-2B

Single Bulb

Two Bulb, Gray

Two Bulb, Black



## Infrared Bar Warmers

- Durable aluminum shell for long life and easy cleanup
- Comes with tubular heating element
- On/off toggle and infinite temperature control models for varying heat settings: low, medium and high
- 120V

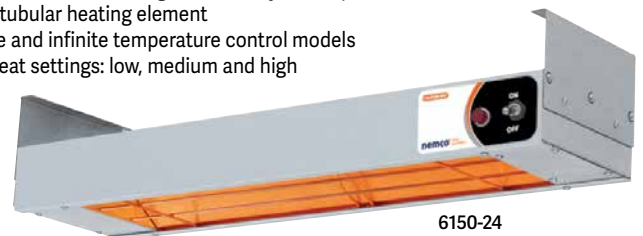

6150-24

with hanging brackets



### On/Off Toggle

6150-24 24" long  
6150-36 36" long  
6150-48 48" long  
6150-60 60" long  
6150-72 72" long

### On/Off Toggle w/Plug & Cord

6150-24-CP 24" long  
6150-36-CP 36" long  
6150-48-CP 48" long  
6150-60-CP 60" long  
6150-72-CP 72" long

### Infinite Controls

6151-24 24" long  
6151-36 36" long  
6151-48 48" long  
6151-60 60" long  
6151-72 72" long

### Infinite Controls w/Plug & Cord

6151-24-CP 24" long  
6151-36-CP 36" long  
6151-48-CP 48" long  
6151-60-CP 60" long  
6151-72-CP 72" long

## Round Food Cookers & Warmers

- No-drip rim keeps serving area clean
- Highly efficient heating distribution
- Wet well use only
- 1 year parts and labor warranty

### Warmers

- FW-7R250 7 qt, 11" dia x 9½"h  
 FW-11R250 11 qt, 12½" dia x 9½"h

### Cooker/Warmers

- FW-7R500 7 qt, 11" dia x 9½"h  
 FW-11R500 11 qt, 12½" dia x 9½"h



FW-7R250



FW-11R500



COUNTERTOP EQUIPMENT



## Food Cooker/Warmer

- Standard opening - 20" x 12" fits most full-size pans with depths of up to 6"
- Energy-efficient design for faster heating and lower utility costs
- Heavy-duty stainless steel body for commercial use
- Heats frozen soups to safe serving temperature in 20 minutes
- 3 settings: Low= 140°F, Medium= 170°F, High= 200°F
- 120V, 1500W, 60Hz
- 1 year warranty

- FW-S600 22½"l x 14⅝"w x 10⅝"h  
 FW-S500 22½"l x 14⅝"w x 9⅝"h

### 27" Length Well Opening

- FW-L600 ⅔ Size, 14⅝"w x 29¾"l x 10⅝"h



ESH-72



## Electric Strip Heaters

- Tubular sheath heating element provides constant, reliable infrared heating
- Heavy-duty aluminum construction
- Ideal for pass-through stations
- Each unit includes undermount bracket set with screws

	Length	Watts
ESH-24	24"	600
ESH-36	36"	860
ESH-48	48"	1100
ESH-60	60"	1400
ESH-72	72"	1750



## Heat Lamp

- Heavy-duty steel tubing
- 3 position adjustable height
- 6 foot power cord
- Includes two shatter resistant clear infrared, 250W/120V bulbs
- 120V, 60Hz
- 1 year limited warranty



EHL-2C 18" x 14" x 24" (adjustable to 26½" or 29"h)

## Electric Strip Heater

- Tubular sheath heating element provides constant and reliable infrared heating
- Extruded aluminum body for durability and cleanliness
- Stand adjusts to three height positions: 17½", 20", and 22½"
- Under-mount bracket and bolt set included
- 120V, 60Hz
- 1 year limited warranty



ESH-1 500W, 24"l x 6"w x 2½"h (without base)

# COUNTERTOP EQUIPMENT

## Glenray® Kettles

- 10½ qt in a compact footprint
- Designed and manufactured for maintenance-free service
- Adjustable temperature control in degrees
- Complete with a S/S food insert, hinged lid and ladle
- Product cards included
- Powder coated black steel
- 120V
- 1 year limited warranty



1021805



1021805 Soup Warmer, 13" dia x 15"h, 400W

1024107 Cooker/Warmer, 13¾" dia x 14¾"h, 800W



## Conveyor Toaster

- Heavy-duty, brushed S/S construction
- 5 minute heat-up time
- Large 2" opening
- Standby function
- Power On and Toaster Ready indicator lights
- Cool-touch side panels
- 15½"w x 18½"d x 13½"h
- Limited 1 year warranty

CTS1000  
450 Slices/hr, 120V



## Pop-Up Toasters

- Extra-high lift control
- Easy-to-use toasting control
- Defrost, reheat and cancel buttons
- Removable crumb trays
- Limited one year warranty
- 120V



WCT702

- Light duty
- Two 1¾" extra wide slots with self-centering bread racks for 2 slices



WCT704

- Full 1¾" wide slots with self-centering bread racks
- 2 long and wide slots for 4 regular size slices or 2 long slices like Italian bread
- 4 slice/2 slice control
- Rocker switch shuts off the back slot when toasting only 1 or 2 slices



WCT708

- Medium duty, 4 slot
- Brushed chrome steel housing
- Four 1¾" extra wide slots with self-centering bread racks
- Electronic browning controls



## HD Commercial Toaster

- Uniformly toasts regular bread, Texas toast, frozen waffles and many other foods
- (4) 1¾" regular slots
- Replaceable industrial heating plates
- Electronic browning controls
- Carriage control lift levers
- Dishwasher-safe crumb tray
- 11¾"w x 10½"d x 9"h
- 120V
- Limited 1 year warranty

WCT800  
300 Slices/hr, 120V





## Holman Conveyor Toaster

- Stainless steel construction
- Compact and versatile, requires minimal counter space and delivers perfect toast, bagels, buns, English muffins, frozen waffles and more for about the price of a pop up toaster
- 1½" clearance

- High performance quartz infrared heaters
- 10" wide belt (2 slices)
- 13¼"w x 18⅝"d x 15⅝"h
- 120V

QCS1-350 350 Slices/hr



## Holman® Ultra-Max® Countertop Conveyor Ovens

- Designed for high-volume commercial food service operations with limited space
- Constructed of stainless and aluminized steel
- Air impingement seals in moisture and flavor plus the airflow design bakes more evenly than traditional ovens
- Electronic controls with large LED display



UM-1833A



### Electric

- 6000 watt metal sheathed element
- 18" conveyor belt, 24" baking chamber and 4" product opening
- 30⅝"d x 20"h
- 208/204V, 6400W

### Gas

- 40,000 BTU stainless steel burner
- 18" x 54" stainless steel conveyor belt and 28" baking chamber
- Extra large 3½" opening
- 39⅜"d x 23⅜"h

### Electric

- UM-1833A 37⅝"w, Stainless Steel Belt
- UM-1850A 50"w, Stainless Steel Belt
- UM-1850AT 50"w, Silicone Belt

### Gas

- UM-1854 60⅜"w, Stainless Steel Belt



1023224



## Pizza/ Snack Ovens

- 22 gauge brushed S/S exterior
- Durable Calrod® heating elements
- Heavy-duty chrome plated baking rack
- Crumb tray for easy clean-up
- Skid resistant feet
- Space saving flip-up handle
- Adjustable temperature control
- 120V

1023230 17½"w x 20"l x 7¾"h, For Pizza up to 12", NSF  
 1023224 24½"w x 24"l x 10"h, For Pizza up to 16", UL/EPH

## Premium Pizza/ Snack Ovens

- High-quality brushed S/S exterior
- Tempered glass door
- 30 minute timer with HOLD feature
- Adjustable temperature control 150° to 450°F (500°F for 1024344)
- 120V

1024213 21⅝"w x 20⅝"l x 9⅝"h, For Pizza up to 12"  
 1024344 24½"w x 24"l x 10"h, For Pizza up to 16"



1024213



# COUNTERTOP EQUIPMENT



P44S



## HearthBake Series Pizza/Pretzel Ovens

- 284° to 680°F temperature range
- Electric 15 minute timer with continuous ring alarm and manual shut-off
- Single or double cooking/baking chambers
- Two cordierite hearth decks per oven chamber with 3/4" deck heights
- Stainless steel exterior
- Unitized, welded, aluminized steel interior



- P18S** 1 Chamber – 22 3/4" w x 17 1/2" h  
2 Decks each 17 3/4" w x 17 1/2" d in a Single Bake Chamber  
1800 watts at 120V or 2850 watts at 208-240V
- P22S** 1 Chamber – 26" w x 17" h  
2 Decks each 20 3/4" w x 20 3/4" d in a Single Bake Chamber  
3600 watts at 208V or 220-240V
- P44S** 2 Chambers each 26" w x 28 1/2" h  
4 Decks each 20 3/4" w x 20 3/4" d in Double Bake Chambers  
7200 watts at 208V or 220-240V



## Countertop Oven

- Stainless steel construction
- Programmable touchscreen controls
- Temperature up to 475°F
- Door switch cutoff for fan blower
- Press-fit removable door gasket for easy cleaning
- One-handed door handle operation
- Cool touch door with dual thermal wide view glass
- Lift up removable side racks
- Holds (5) 13" x 18" pans
- 4" adjustable legs, 2-speed fan
- 208V-240V
- 2 year parts and 1 year labor warranty

NCOT5 29 3/4" w x 27 1/16" d x 26 1/16" h



GS1010



## Manual Multipurpose Ovens

- Removable clean out tray
  - Mechanical 15 minute timer
  - Long life calrod heating elements
  - Flip up handle design for easier storage
  - Bakes (1) 12" original crust pizza in approximately 8-12 minutes
  - 120V
- Model GS1010:
- Opening: 2 1/16" x 17 1/2"
  - Timer features 'hold' option
  - Variable control thermostat from 100° to 675°F
- Model GS1015:
- Opening: 1 1/8" x 13"
  - Preset thermostat, approximately 500°F

- GS1010** 23 3/8" w x 19 1/2" d x 10 1/4" h, 1700W  
**GS1015** 18" w x 15" d x 7 3/4" h, 1450W



## Digital Multipurpose Oven

- Adjustable thermostat, 150° to 500°F
- 30 minute digital display timer
- Quick one-touch setting of 450°F for 10 minutes
- 3" x 13" opening
- Removable clean out tray
- LED display
- Long life calrod heating elements
- Flip up handle design for easier storage
- Formed tray prevents food products from sliding off
- 120V, 1500W

GS1005 18" w x 15" d x 7 3/4" h





### Half Size Convection Ovens

- Set temperature from 200°F to 500°F
  - Cooking time adjustable up to 2 hours or "infinite" time to adjust cooking duration
  - Convection cooking
  - All stainless steel cooking chamber
  - Oven shell entirely made with stainless steel
  - 23.62" w x 27.91" d
- Model GS1115:
- Broil feature
  - 8 cooking configurable options

- Model GS1120 and GS1125:
- 23.62" w x 27.83" d
  - 2 cooking options: Convection or Convection with humidity/steam
  - Reversing motor for cooking uniformity
- Model GS1125:
- Humidity/steam set in manual or automatic
  - 4 cooking steps available
  - Automatic preheating for programmed cooking cycles

Accommodates 3 (18" x 13") ½ Size Pans

GS1105-17	21.06" h, 120V, 1750W
GS1105-28	21.06" h, 208/240V, 2650/2800W
GS1115	22.81" h, 208/240V, 2750/2900W

Accommodates 4 (18" x 13") ½ Size Pans

GS1110-17	23.97" h, 120V, 1750W
GS1110-28	23.97" h, 208/240V, 2650/2800W
GS1120	25.82" h, 208/240V, 2750/2900W
GS1125	25.82" h, 208/240V, 2750/2900W



### Manual Convection Oven

- Stainless steel construction
- Insulated, double wall construction
- Cool touch tempered glass door
- Adjustable time and temperature control
- High speed fan for even air distribution
- Temperatures ranging from 100° to 450°F
- Removable door and rack slides
- Comes with 3 wire racks and (3) 13½" x 10" aluminum baking trays
- Accommodates 3 standard ¼ size sheet pans (not included)
- Will accommodate most 9" x 13" pans
- 120V, 1300W

GS1200 19" w x 18" d x 14¼" h



### Elite Hot Plate

- Stainless steel front, ledge and sides
- 6 open burners
- Pyrocentric lift-off burner heads equipped with continuous pilots for instant ignition

IHPA-6-36 36" w



### Heavy-Duty Thermostatically Controlled Griddle

- (3) 30,000 BTU burners
- 3½" wide grease trough and 1 gallon grease can
- Includes 4" adjustable legs
- 1 year and labor warranty

ITG-36 36" w



### Multi-Purpose Ovens

- Multiple cooking methods: steam, convection, dry, and probe
- Convection baking from 158° to 518°F
- Steam baking from 158° to 266°F
- Comes with 1 core probe
- Touch screen control panel with multiple user programs
- Internal lighting
- Stainless steel baking chamber features rounded corners
- Condensation catching door trays
- Fits 18" x 26" trays
- 33½" w x 36½" d
- 1 year, on-site parts and labor



MP6TE  
6 Tray Capacity, 33" h

MP10TE  
10 Tray Capacity, 45½" h



# COUNTERTOP EQUIPMENT

## Heavy-Duty Counterline Gas Hot Plates

- 33,000 BTU non-clogging burners
- Flush top grate design for pan mobility
- Full width crumb tray
- All stainless steel construction
- All units 30"d x 11"h
- 1 year parts and labor warranty

HDO-12	12" wide, 2 Burner
HDO-24	24" wide, 4 Burner
HDO-24SU	24" wide Step-up, 4 Burner
HDO-36	36" wide, 6 Burner
HDO-36SU	36" wide Step-up, 6 Burner
HDO-48	48" wide, 8 Burner
HDO-48SU	48" wide Step-up, 8 Burner



HDO-24

## Heavy-Duty Counterline Gas Griddles

- 1" thick smooth polished plate
- Stainless steel front and sides
- "Insta-on" thermostatic controls (150° to 400°F)
- 30,000 BTU every 12"
- Hidden grease drawers
- Exclusive NO COLD Zone
- Embedded load sensing thermostat
- All units 33½"d x 20"h typically
- Spark ignition standard
- 24/7 warranty

HDG-24	24" wide
HDG-36	36" wide
HDG-48	48" wide
HDG-60	60" wide
HDG-72	72" wide



HDG-24



## Heavy-Duty Counterline Gas Charbroilers

- Field convertible from radiant to briquette
- Stainless steel burner and cast iron grates
- Two position, two-sided cooking grates
- Universal gas regulator in rear
- 40,000 BTU every 12"
- Hidden grease drawers
- Built-in splash guard
- All units 30"d x 16"h
- 24/7 warranty

HDC-24	24" wide
HDC-36	36" wide
HDC-48	48" wide



HDC-36



HDCS-60  
Stand Shown with Counterline Equipment  
(Sold Separately) and optional casters

## Heavy-Duty Counterline Stands

- 2" stainless steel tubular legs
- All stainless steel welded construction
- Adjustable bullet feet
- Optional casters available

HDCS-24	24" wide
HDCS-36	36" wide
HDCS-48	48" wide
HDCS-60	60" wide
HDCS-72	72" wide

## Black Diamond Gas Charbroilers

- Fully welded stainless steel front bullnose and backsplash
- One stainless steel burner for every 12" of width
- Cast iron grill grates are reversible and adjustable
- 3/4" rear NPT gas inlet
- 26"d x 15 1/4"h

	Width	Burners	BTU
BDECTC-16/NG	16"	1	30,000
BDECTC-24/NG	24"	2	60,000
BDECTC-36/NG	36"	3	90,000
BDECTC-48/NG	48"	4	120,000



BDECTC-36/NG



BDCTG-36T



## Black Diamond Thermostatic Griddles

- Stainless steel front, sides and splash guards
- Griddle plate is made up of 1" thick polished steel
- Adjustable thermostat from 200° to 450°F
- 3/4" rear NPT gas inlet
- 30"d x 16 1/4"h

	Width	Burners	BTU
BDCTG-24T	24"	2	60,000
BDCTG-36T	36"	3	90,000
BDCTG-48T	48"	4	120,000
BDCTG-60T	60"	5	150,000

## Star-Max® Gas Charbroilers

- 40,000 BTU H-style cast iron burners every 12" of width
- Heavy-duty, reversible cast iron grates can be individually positioned (flat or slanted)
- Stainless steel, 2 3/4" high tapered splash guard
- Shipped natural gas with LP conversion kit
- 29"d x 15 1/2"h
- 2 years parts and labor warranty



### Lava Rock Gas Charbroilers

- Natural lava rock briquettes provide superior heat distribution and vaporize drippings

6015CBF	15" wide
6024CBF	24" wide
6036CBF	36" wide
6048CBF	48" wide

### Radiant Gas Charbroilers

- Radiant models feature heavy-duty S/S radiants
- Stainless steel construction

6115RCBF	15" wide
6124RCBF	24" wide
6136RCBF	36" wide
6148RCBF	48" wide



6048CBF



624TF



5124CF



## Star-Max® Manual Gas Griddles

- Highly polished 1" thick steel plate
- 28,300 BTU aluminized steel U-shaped burner every 12"
- New longer lasting, heavy duty metal knobs
- Manual control with standing pilot
- Stainless steel front bullnose and 4 1/2" splash guards
- Thermostatic controls
- Shipped natural gas with LP conversion kit
- 29"d x 15 1/2"h
- 2 years parts and labor warranty

615TF	15" wide	636TF	36" wide
624TF	24" wide	648TF	48" wide

## Star-Max® Electric Charbroilers

- 2 3/4" high stainless steel tapered splash guard, double wall aluminized steel side panels, S/S bull nose front and front control panel w/black polycarbonate faceplate
- Infinite control every 12"
- Heavy-duty removable cast iron grates
- Swing-up heating element assembly can be locked in a vertical position
- Removable water pan
- Heavy-duty 4" adjustable legs
- 25 5/8"d x 14 1/4"h
- 2 year parts and labor warranty

5124CF	24" wide	5136CF	36" wide
--------	----------	--------	----------

# COUNTERTOP EQUIPMENT



436T



## Gas Countertop Griddles

- 1" thick griddle surface
- Rear and side splash guard and a grease trough for easy cleanup
- 33.3"d x 18"h



### Accu-Temp™ Snap-Action Thermostat - Up to 450°F

Steel Plate	Chrome Plate	Width	BTU
424T	424TC	24"	60,000
436T	436TC	36"	90,000
448T	448TC	48"	120,000
460T	460TC	60"	150,000
472T	472TC	72"	180,000

### Selectronic™ Solid-State System - Up to 450°F

424S	424SC	24"	60,000
436S	436SS	36"	90,000
448S	448SC	48"	120,000
460S	460SC	60"	150,000
472S	472SC	72"	180,000



336T



## Electric Countertop Griddles

- 1" thick griddle surface
- Rear and side splash guard and a grease trough for easy cleanup
- 30.75"d x 18"h
- 208/240/480V

### Snap-Action Thermostat - Up to 450°F

Steel Plate	Chrome Plate	Width
324T	324TC	24"
336T	336TC	36"
348T	348TC	48"
360T	360TC	60"
372T	372TC	72"

### Solid-State System - Up to 450°F

324S	324SC	24"
336S	336SS	36"
348S	348SC	48"
360S	360SC	60"
372S	372SC	72"

## Don't Forget the Scrapers!

These handy tools help keep your grill clean!



See page 114 for details



436CB



## Radiant Gas Charbroilers

- Cast iron burners and heavy-duty steel radiants for increased durability
- Uniform heat distribution provides corner-to-corner temperature consistency between 625° and 700°F
- High-capacity cast iron grates can be adjusted independently in 6" sections to be flat or inclined
- 5" tapered splash guard
- Large capacity water pan and deflector tray for easy cleanup
- Cool-to-the-touch stainless steel bullnose
- Adjustable 4" stainless steel legs
- 33.3"d x 18"h

	Width	BTU
424CB	24.1"	80,000
436CB	36.1"	120,000
448CB	48.1"	160,000
460CB	60.1"	200,000
472CB	72.1"	240,000



## Cecilware® Pro Gas Hot Plates

- Stainless steel construction
- Natural or LP gas (conversion kit included)
- Individually controlled burners with 44,000 BTU
- Heavy-duty cast iron trivets
- Durable anti-clogging dual-ported burners
- Also available in 6-burner
- 2 year parts and 1 year labor warranty



HPCP424



Cecilware®

HPCP212 2 Burners, 12"w x 20"d  
HPCP424 4 Burners, 24"w x 20"d





GCP24



CCP24

### Cecilware® Pro Gas Griddles

- Heavy-duty stainless steel double-wall construction, high polished plate
- Cool-to-the-touch bullnose
- 1" thick griddle plate
- 30,000 BTU high-performance burners
- Natural or LP gas (conversion kit included)
- Manual, independent cooking zones
- Bottom-welded plate for accurate heat distribution
- Stainless steel full-cooking depth dual-ported burners, adjustable pilot for each burner with easy front panel access
- Also available in 15" and 48" widths
- 2 year parts and 1 year labor warranty

GCP24 2 Burners, 24"w  
GCP36 3 Burners, 36"w



**Cecilware®**  
**PRO**

### Cecilware® Pro Gas Charbroilers

- Stainless steel double-wall construction
- Cool-to-the-touch bullnose
- Natural or LP gas (conversion kit included)
- Angled sidewalls and bottom plate reflect heat into cooking zone
- Reversible, heavy-duty cast iron grilling grates
- Manual, independent cooking zones; 40,000 BTU per burner with adjustable pilots
- Grates can be tilted for different heating levels
- Can alternate between lava rock and radiant cooking methods
- Also available in 15" and 48" widths
- 2 year parts and 1 year labor warranty

CCP24 2 Burners, 24"w  
CCP36 3 Burners, 36"w



## How to Clean a Steel Griddle Plate

1. At the end of service, allow griddle to cool down to 300° to 350°F and apply room temperature water.
2. Use a griddle scraper to remove debris from the surface.
3. Apply oil and use a griddle brick on the surface. Rub with the grain of the metal while the griddle is still warm.
4. Another viable method is to use a griddle-specified detergent on the plate surface, but be sure the detergent is thoroughly removed by flushing the cooking surface with room temperature water.
5. For hard to reach places, a putty knife may also be used to remove debris.



# COUNTERTOP EQUIPMENT



CM-636



## Gas Charbroilers

- Double wall stainless steel construction, fully insulated on all sides
- Available with stainless steel radiant, cast radiant or ceramic coal
- ½" E-Z tilt top grid drains grease into front trough
- All stainless steel burners and radiant burner covers
- 6" stainless steel service shelf with towel bar, water tubs and scraper
- Lower rack available for use as cheese melter

### Floor Models

- Stainless steel cabinet base
- 6" legs, optional casters available
- 34"h

### Counter Models

- 4" legs optional
- 17"h

FM-624	24"w, 60,000 BTU
FM-630	30"w, 90,000 BTU
FM-636	36"w, 105,000 BTU
FM-648	48"w, 150,000 BTU
FM-660	60"w, 195,000 BTU
FM-672	72"w, 240,000 BTU

CM-624	24"w, 60,000 BTU
CM-630	30"w, 90,000 BTU
CM-636	36"w, 105,000 BTU
CM-648	48"w, 150,000 BTU
CM-660	60"w, 195,000 BTU
CM-672	72"w, 240,000 BTU



MKG-36



## Gas Griddles

- 1" thick heavy-duty griddle plate
- Temperature accuracy of ±15°F
- Temperature control from 200° to 450°F
- In-line burners every 6" for improved heat pattern
- 60% larger grease containment to prevent overflow
- Protected flue area to prevent debris accumulation
- Standard with piezo spark ignition system
- 4" legs standard (can be flush mounted)

MKG-24	24"w, 60,000 BTU
MKG-36	36"w, 105,000 BTU
MKG-48	48"w, 150,000 BTU
MKG-60	60"w, 195,000 BTU



## APM Shorty Series Countertop Gas Charbroilers

- Available with stainless steel radiant, cast radiant or ceramic coal (radiant style converts to coal style)
- Stainless steel sides, front and 6" service shelf with towel bar and scraper
- ½" E-Z tilt top grid drains grease into front trough
- Suspended crumb tray and grease box with handles
- Smoker box not available
- 4" legs optional

APM-624	24"w, 60,000 BTU	APM-648	48"w, 150,000 BTU
APM-630	30"w, 90,000 BTU	APM-660	60"w, 195,000 BTU
APM-636	36"w, 105,000 BTU	APM-672	72"w, 240,000 BTU



APM-636



## Deluxe Ceramic Briquettes

- Excellent, even heat retention
- Covers 236 square inches
- 1½" square
- Pink



28-1563 59 per Package



## Lava Rocks

- Covers approximately 2 sq ft

28-1037 7 lb Bag



## Universal Griddle Rail

- Stainless steel
- Versatile—fits most griddle manufacturers and models
- Adjusts from 8" to 13" deep
- Works with ninth-, sixth-, and third-size pans (sold separately)
- Includes Allen wrench and 2 set screws

280-2203 36"w x 2½"h





## Star-Max® Vertical Broilers

- Features a full rotisserie rod for maximum control of broiling speeds and accommodates a variety of meat products and sizes
- Fully adjustable temperature for a crisp, juicy and flavorful taste
- 5-45 lb meat capacity
- Simple disassembly for easy clean-up
- Automatic friction drive stops rotation during slicing, allowing for quick and easy carving
- Moveable side flaps to direct heat
- Made in the USA
- 16<sup>1</sup>/<sub>16</sub>"w x 24<sup>3</sup>/<sub>32</sub>"d x 32"h



VBG30 Gas, 30,000 BTU  
VBE30 Electric, 208V



VBG30  
ETL  
Intertek

## Star-Max® Fryers

- Lift-out nickel plated kettle
- Stainless steel cabinets
- Adjustable high-limit safety thermostat
- Only 4½ minutes to preheat to 350°F
- 4" legs
- 208/240V
- 2 year warranty



301HLF



		Capacity	W x D x H
301HLF	Single Pot	15 lb Oil	18" x 20" x 17"
530TF	Twin Pot	30 lb Oil	24" x 24" x 16¾"

## Countertop Fryer

- All stainless steel construction
- Thermal overload device
- Safety cutout switch automatically shuts off heating element when removing the tank
- 15 lb fry pot with 2 baskets
- 11" w x 17½" d x 15¾" h
- 2 year parts and 1 year labor warranty



EL15 120V  
EL25 240V

## GRINDMASTER

EL25  
UL LISTED

## Countertop Deep Fryers

- Removable stainless steel fry well
- Removable power head
- Commercial fry basket with safe secure handle
- Fry well cover included
- Extra fast heat up
- 120V, (2x) 1800W, (2x) 15A, 60 Hz
- 1 year warranty

**winco**



		Capacity	W x D x H
EFS-16	Single Well	16 lb Oil	11¾" x 16" x 13¾"
EFT-32	Double Well	32 lb Oil	21¼" x 16" x 13¾"



EFT-32

# COUNTERTOP EQUIPMENT



## Pizza and Snack Merchandiser

- Ideal for self service venues with colorful graphics to entice customers
- Adjustable thermostat (80° to above 160°F)
- Thermometer included inside merchandiser
- Front and back doors for easy accessibility
- Tempered glass side panels, polycarbonate doors and stainless steel corner posts
- 19" w x 19" l x 19 1/2" h
- 120V

**tomlinson**



1023226 (3) 17" x 17" Heated Shelves with Racks



## Open View Merchandisers

- Graphic headers on all 4 sides (front 3 are backlit)
- High visibility on 3 sides
- Recessed water pan for optional moist heat
- 1/4" tempered glass, no corner posts
- Brushed stainless steel 4" legs
- Backside header cover opens to access controls

6421



**nemco** | FOOD EQUIPMENT

- 6420 Pizza, 3-Tier, 12" dia Racks
- 6421 Pizza, 3-Tier, 18" dia Racks
- 6422 Pizza, 4-Tier, 18" dia Racks
- 6423 Pretzel, 2-Tier, Prong Revolving Rack
- 6424 Hot Foods, 3-Tier, Angled 15" Square Shelves
- 6425 Hot Foods, 3-Tier, Angled 19" Square Shelves

**GLOBAL solutions**  
by nemco



## Heated Merchandisers

- Illuminated to catch attention and drive sales
- Temperature control to above 150°F
- 120V
- Made in the USA



GS1300-24



GS1400-25

### Open w/Aluminum Product Trays and Wire Shelves

- GS1300-24 (8) 3 7/8" Trays, (2) 8" Trays, 4 Grill Racks
- GS1300-24S (8) 3 7/8" Trays, (2) 8" Trays, 4 Grill Racks, Slanted Shelves

### Enclosed w/Heated Solid Shelves

- GS1410 2-tier, 15" Square Shelves
- GS1415 3-tier, 19" Square Shelves

### Enclosed w/Wire Shelves

- GS1400-16 (2) 18" Shelves
- GS1400-16-2 (2) 18" Shelves, Pass-thru
- GS1400-25 (4) 18" Shelves
- GS1400-25-2 (4) 18" Shelves, Pass-thru

### Enclosed w/Wire Shelves, Slanted Front

- GS1405 2 Shelves



GS1405



GS1410



8075GD

**nemco** | FOOD EQUIPMENT

### Hot Dog Roller Grills & Guards

- 360° roller rotation prevents residue buildup
- Individual roller heating elements ensure heating consistency
- Removable drip pan
- Requires no ventilation system
- Seven heat settings offer versatile temperature control
- 120V

#### Hot Dog Roller Grills\*

- 8010 Holds 10 Hot Dogs, 16" w x 11" d x 7 1/4" h
- 8018 Holds 18 Hot Dogs, 18 1/2" w x 16 1/4" d x 7" h
- 8027 Holds 27 Hot Dogs, 22 1/4" w x 16 1/4" d x 7" h
- 8036 Holds 36 Hot Dogs, 29 1/2" w x 16 1/4" d x 7" h
- 8045N Narrow, Holds 45 Hot Dogs, 22 1/4" w x 25 3/4" d x 7" h
- 8045W Wide, Holds 45 Hot Dogs, 35 1/2" w x 16 1/4" d x 7" h
- 8075 Holds 75 Hot Dogs, 35 1/2" w x 25 3/4" d x 7" h



\*Also available with non-stick Gripslt® rollers (Gripslt is Silverstone with grip and abrasion resistant additive)

### Moist Heat Bun Warmers

- Keep buns, condiments and other foods warm, fresh and ready to serve
- Stainless steel construction
- Stackable design saves space
- 10 5/8" h, 120V

	Capacity	Fits Roller Grill
8018-BW	24 Buns	8018
8027-BW	32 Buns	8027
8036-BW	48 Buns	8036
8045N-BW	32 Buns	8045N
8045W-BW	64 Buns	8045W
8075-BW	64 Buns	8075



#### Self-Serve Guards w/Door

	Fits Roller Grill
8010GD	8010
8018GD	8018
8027GD	8027
8036GD	8036
8045NGD	8045N
8045WGD	8045W
8075GD	8075

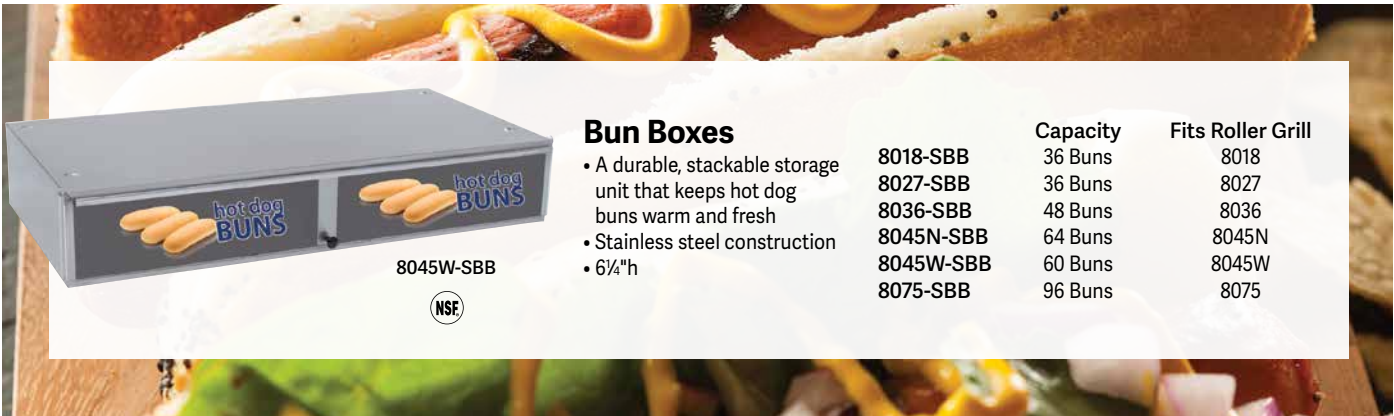

### Bun Boxes

- A durable, stackable storage unit that keeps hot dog buns warm and fresh
- Stainless steel construction
- 6 1/4" h

	Capacity	Fits Roller Grill
8018-SBB	36 Buns	8018
8027-SBB	36 Buns	8027
8036-SBB	48 Buns	8036
8045N-SBB	64 Buns	8045N
8045W-SBB	60 Buns	8045W
8075-SBB	96 Buns	8075



### Hot Dog Steamer and Merchandiser

- Stainless steel construction
- Pull down full view tempered glass door
- Humidity compartment control to keep hot dogs and buns fresh and warm
- Adjustable thermostat control
- 11 quart water reservoir for all day steaming
- Accommodates up to 170 hot dogs and 18 buns
- 120V



35SSA 14 3/4" w x 16 1/2" d x 15 5/8" h



COUNTERTOP EQUIPMENT

# COUNTERTOP EQUIPMENT

## Plastic Countertop Dispensers

- Pump delivers a perfect portion with one smooth motion-adjustable up to 1 oz
- Made of durable, BPA-free food-grade materials
- Available in white or black plastic base, with a black lid
- Transparent pump body allows for quick product identification
- Accepts standard 1.5 gallon pouches
- Clear panel on lid accepts paper or card stock flavor indicator for easy and mess-free identification
- 6½"w x 13"d x 17½"h

10950 Black/Black  
10951 Black/White

**nemco** | FOOD EQUIPMENT



## Stainless-Steel Countertop and Drop-In Dispensers

- Pump delivers a perfect portion with one smooth motion-adjustable up to 1 oz
- Stainless-steel housing adds a higher level of style and class
- Transparent pump body allows for quick product identification
- Accepts standard 1.5 gallon pouches
- Large front display area for custom branding or flavor graphics

**nemco** | FOOD EQUIPMENT



Drop-In

Countertop

Countertop		W x D x H	Drop-In		W x D x H
10961	Single	6½" x 13" x 15¾"	10966	Single	7" x 11" x 14"
10962	Double	13" x 13" x 15¾"	10967	Double	12" x 11" x 14"
10963	Triple	19½" x 13" x 15¾"	10968	Triple	18" x 11" x 14"
10964	Quadruple	26" x 13" x 15¾"	10969	Quadruple	23" x 11" x 14"
10965	Quintuple	32½" x 13" x 15¾"	10970	Quintuple	29" x 11" x 14"

## Nacho Chip Warmers

- Heat duct baffling system assures uniform temperatures throughout cabinet for consistent holding of product
- Stainless steel interior and exterior for easy sanitation and long lasting clean appearance
- First-in first-out gravity feed ensures freshness
- High performance convection heater with adjustable thermostat



	Capacity	W x D x H	Watts
CW1	20 gallons	28 $\frac{3}{8}$ " x 25 $\frac{1}{2}$ " x 27 $\frac{1}{4}$ "	1040
CW2E	22 gallons	22 $\frac{3}{4}$ " x 23" x 38 $\frac{3}{4}$ "	1530
CW4E	44 gallons	30 $\frac{1}{8}$ " x 27 $\frac{7}{8}$ " x 45 $\frac{5}{8}$ "	1530



COUNTERTOP EQUIPMENT



## Stainless Steel & Lighted Warmers

- Warm cheese, chili, fudge, butter or other food products from a #10 tin (3 $\frac{1}{2}$  qt only), or optional 3 $\frac{1}{2}$  and 11 quart Bain Marie or 4 quart vegetable inset with cover
- Warmers have 3 $\frac{1}{2}$  or 11 qt wells for heating a variety of viscous food
- Select from ladle serve units, portion control pumps or pumps with heated spout
- Adjustable thermostat for precise temperature control and storing product at proper serving temperature
- Lighted units have a selection of attractive colorful signs that are easily changed (without tools) to match products and build impulse sales



3WSA-HS



3WLA-HS



3WLA-P



3WLA-W



3WLA-4H



3WLA-B



### 3 $\frac{1}{2}$ Quart Warmers - 9" w x 15 $\frac{1}{2}$ " d

- 3WSA-HS† Stainless Warmer w/Pump & Heated Spout, 15 $\frac{1}{2}$ " h
  - 3WLA-HS† Lighted Warmer w/Pump & Heated Spout, 15 $\frac{1}{2}$ " h
  - 3WLA-P† Lighted Warmer w/Pump, 15 $\frac{1}{2}$ " h
  - 3WLA-W† Lighted Warmer w/1 oz Ladle, 9 $\frac{1}{2}$ " h
  - 3WLA-4H† Lighted Warmer w/Hinged Lid & 1 oz Ladle, 12 $\frac{1}{2}$ " h
  - 3WLA-B Lighted Warmer w/Butter Pump, 15 $\frac{1}{2}$ " h
- †Includes Nacho, Fudge, Chili, Chili Dog & BBQ signs

### 11 Quart Warmers - 13 $\frac{3}{4}$ " d x 15 $\frac{1}{2}$ " h

- 11WLA Lighted Warmer, 11 $\frac{1}{2}$ " w
- 11WLA-P Lighted Warmer w/Pump, 18 $\frac{3}{4}$ " w
- 11WLA-HS Lighted Warmer w/Pump & Heated Spout, 18 $\frac{3}{4}$ " w



# COUNTERTOP EQUIPMENT

## JetStar® Popcorn Poppers

- Pops (135) 1 oz servings per hour
- Nickel plated 6 oz steel kettle
- Magnetic catch holds one-piece kettle lid up for easy loading and unloading
- Swing up/down kettle design allows easy dispensing of popped corn into the cabinet and is easy to clean
- A 50 watt warming element keeps popcorn fresh and crisp when you want to snack
- Cabinet is constructed of 1/8" thick tempered glass panels with four full length aluminum corner posts for stability and maintenance free operation

- 39D-A Wood Grain Popper, 21"w
- 39S-A Stainless Steel Popper, 19½"w
- 39-A Yellow Popper, 19½"w
- 39R-A Red Popper, 19½"w

- Heavy gauge clear Lexan doors and full length aluminum hinges with magnetic catch
- Clear Lexan drop panel provides greater visibility for merchandising popcorn
- Stainless steel old maid drawer
- Eye level 2 switch control panel: top switch engages motor and kettle heat, bottom switch engages light and corn deck
- A 75 watt display light highlights popcorn and builds impulse sales
- Attractive colorful popcorn graphics
- 14¼"d x 25¼"h



39D-A



Optional sneeze guards available for self-serve operations. Please contact your local sales representative for details.

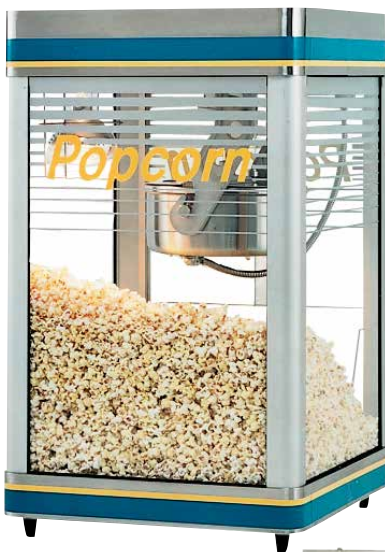

## Galaxy Popcorn Poppers

- Brings smell, taste and fun to a variety of foodservice operations
- Euro style design with etched glass
- Kettle design allows safe and easy dispensing
- Heated stainless steel corn deck keeps your popcorn fresh and crisp
- Heavy-duty aluminum posts, plexiglass door and stainless steel construction

- Clear two-piece plexiglass door with aluminum hinge and magnetic catch
- Stainless steel drawer for easy removal of old maids (unpopped kernels)
- Top control panel has two on/off switches: top switch is for kettle heat, bottom is for corn deck and heat lamp

G8-Y



21¼"w x 21¼"d x 35½"h

G8-Y 8 oz Popper, (170) 1 oz Servings per hour

G12-Y 12 oz Popper, (240) 1 oz Servings per hour

28¼"w x 28¼"d x 35½"h

G14-Y 14 oz Popper, (280) 1 oz Servings per hour

G18-Y 18 oz Popper, (360) 1 oz Servings per hour



86SS

## JetStar® Popcorn Poppers

- Makes (170) 1 oz servings per hour
- Solid extruded aluminum corner posts with 1/8" thick tempered glass panels and two 3/16" thick plexiglass doors with full length aluminum hinges
- 1000 watt, 8 oz capacity nickel plated steel popping kettle with stainless steel exterior shell
- Wire cage protects the 75 watt display lamp

- 50 watt warming element under stainless steel corn deck and old maid drawer are standard
- 19½"w x 14¼"d x 30½"h

86S Standard

86SS Self-Serve



## Mini JetStar Popcorn Popper

- Easy clean, aluminum popping kettle
- Popper cabinet has a one-piece clear polycarbonate wrap body and a 3/16" thick polycarbonate door with a one-piece hinge
- Outfitted with a 1000 watt, 4 oz capacity, aluminum popping kettle with stainless steel exterior shell
- 50 watt flood light supplied with unit
- 50 watt heated corn pan
- (115) 1 oz servings per hour

J4R 15½"w x 14¾"d x 23¾"h



## Electric Meat Saws

- All stainless steel body and internal parts
- Electrical control system
- Motor drive system
- Sealed protection against water damage
- Safety sensor automatically shuts off the power if the door is open
- Thickness adjustment plate
- 2 year parts and labor warranty



GBS-270S



- GBS-230A Vertical 66" Blade, ¾ hp, NSF
- GBS-270S Vertical 93" Blade, 1½ hp, NSF
- GBS-450S Vertical 126" Blade, 3 hp, ETL Sanitation

## Heavy-Duty Meat Grinder

- Heavy-duty gear driven meat grinder with powerful 1½ hp motor
- Space-saving compact design
- Stainless steel food contact zone
- Removable bowl assembly and feed tray
- Ergonomic style hand wheel ring
- Sealed gear box
- The bowl assembly uses a safety opening
- 2 year labor and parts warranty

GG-22 660 lb/hr Capacity



**GERMAN KNIFE**

A division of Turbo Air

## Manual Meat Slicers

- Anodized aluminum
- Blade sharpener
- Belt drive
- Perspex Protector Guard
- Waterproof and emergency shut off switch
- Robust handle
- 110V

- HBS-195JS 8" Blade, ½ hp
- HBS-220JS 9" Blade, ½ hp
- HBS-250L 10" Blade, ½ hp
- HBS-300L 12" Blade, ½ hp

**eurodib**



HBS-250L



## Heavy-Duty Premium Slicers

- Stainless steel for food contact zones
- 12" knife
- ½ hp gear driven knife motor
- GS-12A has 9-speed chute motor and self-diagnosis function
- Oil lubrication system on top and bottom slide shafts
- No belts to slip or break
- Ergonomic style chute handle grip
- Top mount knife sharpener
- Precise slice thickness adjustment
- 2 year parts and labor warranty
- 115V

- GS-12A Automatic with ½ hp Chute Motor
- GS-12M Manual

**GERMAN KNIFE**

A division of Turbo Air



GS-13A



FOOD PREP

# FOOD PREP

Ready to learn more about these great products? **PLAY VIDEO**



4612

## Manual Slicers

- 12" German hollow ground blade
- Belt driven
- Carriage detaches for easy washing/sanitization



		Slice Thickness	HP
<b>Aluminum Construction</b>			
4612	Light Duty	1/2"	1/4
6612M	Medium Duty	1/2"	1/2
<b>Stainless Steel Construction</b>			
7512	Medium/Heavy-Duty	7/8"	1/2



## BLACK◆DIAMOND®

### Planetary Mixers

- Heavy-duty stainless steel construction
- Powerful motor
- Includes wire whisk, dough hook, flat beater and mixing bowl
- 3 speed
- 120V

BDPM-20 and BDPM-30 feature:

- 60 minute timer
- #12 hub

	Capacity	HP
BDPM-10	10 qt	3/4
BDPM-20	20 qt	1 1/2
BDPM-30	30 qt	2 1/2



BDPM-20



M20A



## Planetary Mixers

- Gear driven
- Includes stainless steel whip, hook and beater
- Safety switch on guard and bowl
- M60A bowl on wheels for easy movement
- Not suitable for pizza, pita or bread dough
- 1 year parts and labor warranty



	Capacity	HP
110V		
M10	10 qt	3/4
M20A	20 qt	1 1/2
M30A	30 qt	2
<b>208-240V, 3PH</b>		
M40A	40 qt	2
M60A	60 qt	3 1/2

## Planetary Mixer

- Designed specifically for heavy-duty mixing applications
- 3 speed
- Heat treated carbon steel gears
- The grease packed ball bearing and air cooled motor ensure quiet and efficient continuous operation
- Manual bowl lift

- Includes: stainless steel bowl, bowl guard w/magnetic lock, spiral dough hook, flat beater and wire whip

	Capacity	HP
GEM110	10 qt	1/2
GEM120	20 qt	1 1/2
GEM130	30 qt	2



A Division of the Legacy Companies

GEM130





## Planetary Mixer

- Stainless steel bowl, safety guard and mixing tools
- 99 minute timer
- 7 programmable speeds and time settings
- No need to stop mixer to change speed
- Emergency stop
- Includes stainless steel dough hook, whip and flat beater
- See through, lifting bowl guard with safety interlock
- Additional models available with capacities ranging from 10 to 140 qt
- 208-240V



20 speed digital control



BTF020 20 qt Capacity, 4 hp



## Spiral Mixer

- Simple to use automatic digital control
- 9 personalized programs
- 3-10 minutes mixing time
- Unique S/S bowl with high center, eliminates feeder post
- 2 powerful independent heavy-duty motors, one for bowl and one for hook
- Stainless steel safety guard, bowl and mixing tools
- Mounted on casters

- Additional models available with capacities ranging from 30 to 375 qt
- 208-240V

AEF025SP  
50 qt Capacity, 4 hp



FOOD PREP

## Countertop Dough Sheeters

- Sheet up to 600 pieces per hour
- Ideal for pizzas, flour tortillas, wraps, flat bread, naan, pita, pierogi, dough, wraps, etc.
- Ideal for products with an absorption rate of 50-60%
- Removable scrapers
- Adjustable roller gap
- Top rollers: 3½" dia. x 10" length
- Bottom rollers: 3½" dia. x 20" length
- Heavy gauge, steel frame
- Stainless steel infeed and chute
- Sealed bearings
- Two year parts and one year labor warranty

	Capacity	Dimensions
<b>Up to 12" Diameter</b>		
DL12DP	1 to 10½ oz	17"w x 10⅝"d x 25¼"h
DL12SP	1 to 10½ oz	17"w x 10⅝"d x 12½"d
<b>Up to 18" Diameter</b>		
DL18DP	1 to 28 oz	20½"w x 13"d x 31½"h
DL18P	1 to 28 oz	22½"w x 13"d x 32¼"h
DL18SP	1 to 10½ oz	22"w x 10⅝"d x 13⅝"h



DL12DP

Tables fold upright for storage and movement

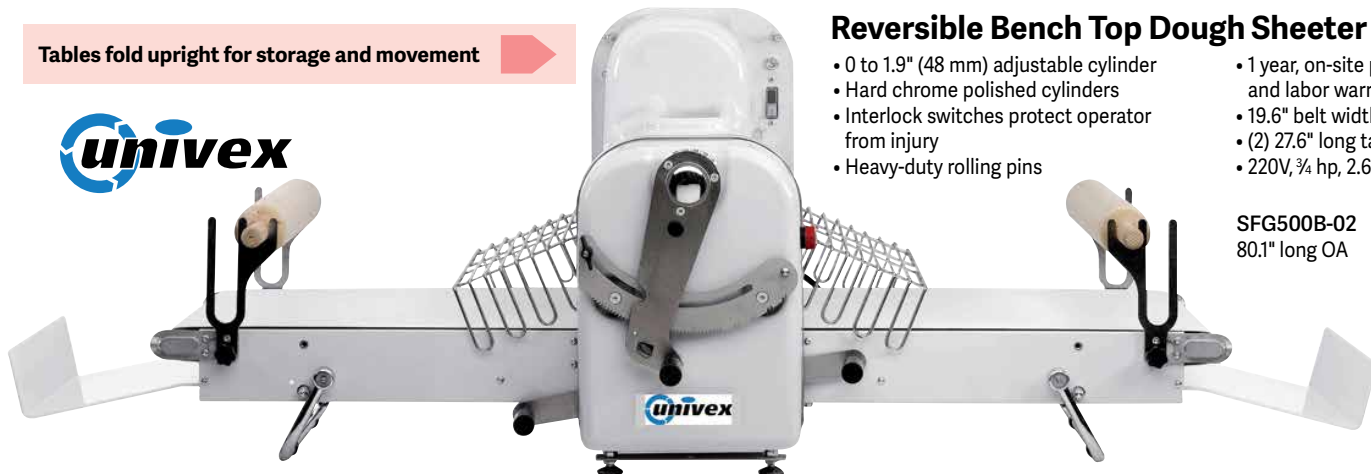

## Reversible Bench Top Dough Sheeter

- 0 to 1.9" (48 mm) adjustable cylinder
- Hard chrome polished cylinders
- Interlock switches protect operator from injury
- Heavy-duty rolling pins
- 1 year, on-site parts and labor warranty
- 19.6" belt width
- (2) 27.6" long tables
- 220V, ¾ hp, 2.6 Amp

SFG500B-02  
80.1" long OA

# FOOD PREP



## Dough Divider & Rounder

- Semi-automatic; divides and rounds to exact weight by 11 or 14 sections
- Automatic rounding with timer
- Great for bread and pizza dough
- One-year, on-site parts/labor warranty
- 115V, ½ hp



DR11

11-23 oz, 11 Portions



## Semi-Automatic Bun Divider/Rounder

- Divides and rounds dough balls
- Select dividers produce from 15 up to 36 equal weight and shaped pieces at once in under 7 seconds
- Simple to use leveling feet
- Simple controls: dual start buttons for safety
- Programmable control board



SBDR15  
SBDR36

3.5 oz to 9.1 oz, 15 Pieces, 1800 Pieces/hr  
1.2 oz to 3.8 oz, 36 Pieces, 4300 Pieces/hr



Shown with optional storage container



## Food Processor

- Versatile prep machine capable of preparing up to 290 - 485 lb of fresh vegetables, fruit and more per hour
- Stainless steel and polished die cast aluminum construction
- Disc speed of 300 RPM
- Powerful ¾ hp fan-cooled motor for high output and durability
- Double interlock on feed hopper and product pusher for a safe continuous-feed operation
- Over 20 blades available including: slicing, grating, shredding, dicing and julienne
- 115/60/1, .07 hp

UFP13

11" w x 20 1/8" d x 20 1/8" h



## Pasta Machine

- Planetary spiral mixer for easy dough mixing
- Easy to remove bowl and spiral for cleaning and sanitizing
- Optional short pasta cutter with variable speed
- 14 different plates are available
- 220V



UPASTA

Bowl Capacity: 21.1 qt, Dough Capacity: 8.8 lb

## Multifunction Vegetable-Prep Machines

- Wide opening and blade diameter optimize feed capacity
- Processes 5 lb/minute
- Includes  $\frac{5}{32}$ " slicing disk and  $\frac{5}{64}$ " grater/shredder
- Cutting tool changeout is super easy
- 11 $\frac{1}{8}$ "w x 13 $\frac{3}{8}$ "d x 18 $\frac{3}{16}$ "h

RG-50 w/Dicing  
RG-50S w/o Dicing



**nemco**  
powered by **HALLDE**

## Vertical Cutter/Blender

- Three-scraper system with handle works with a simple rocking motion
- Accepts up to 3 quarts for a final 1 $\frac{1}{2}$  quart yield
- Two speeds with a pulse function apply ideal RPM for cutting or blending
- 11 $\frac{1}{8}$ "w x 13 $\frac{3}{8}$ "d x 17 $\frac{3}{16}$ "h

VCB-32



## Combi Cutters

- For blending, accepts up to 3 quarts for a final 1 $\frac{1}{2}$  quart yield
- For vegetable prep, processes 5 lb/minute
- Includes  $\frac{5}{32}$ " slicing disk and  $\frac{5}{64}$ " grater/shredder
- Speeds change automatically, per the desired function, with no manual adjustments needed
- 11 $\frac{1}{8}$ "w x 13 $\frac{3}{8}$ "d x 18 $\frac{3}{16}$ "h

CC-34 w/Dicing  
CC-32S w/o Dicing

**nemco**  
powered by **HALLDE**



**eurodib**

## Vacuum Machine

- Sensor control, double seal and 5" high lid
- 15-35 second machine cycle
- 120V
- 1 year warranty parts and labor

ARCTIC11 17 $\frac{7}{16}$ "l x 13 $\frac{1}{16}$ "w x 13 $\frac{3}{8}$ "h, 16" Seal Bar



## Vacuum Machine

- Sensor control, double seal, soft air
- 15-35 second machine cycle
- 1 year warranty parts and labor
- 120V

CHINOOK16D 21 $\frac{1}{8}$ "l x 17 $\frac{7}{16}$ "w x 15 $\frac{1}{16}$ "h, 13 $\frac{1}{2}$ " Seal Bar

**eurodib**

## Vacuum Machine

- Sensor control, 2x sealing beams
- 15-35 second machine cycle
- 220V
- 1 year warranty parts and labor

CYCLONE201D 28"l x 27 $\frac{1}{2}$ "w x 40 $\frac{3}{8}$ "h, 20 $\frac{1}{2}$ " Seal Bar



# FOOD PREP

## Big Stix® Immersion Blenders

- Lightweight and ergonomic – rubberized comfort grip and handle allows for safe and controlled operation
- S/S shafts are easily removable and dishwasher safe
- 1 hp motor, 750 watt
- 5" w x 5½" d
- 120V
- 1 year limited warranty



- WSB50 40 qt Capacity, 12" Shaft, 27" h
- WSB55 60 qt Capacity, 14" Shaft, 29" h
- WSB60 100 qt Capacity, 16" Shaft, 31" h
- WSB65 140 qt Capacity, 18" Shaft, 33" h
- WSB70 200 qt Capacity, 21" Shaft, 36" h



## Food Processors

- Sealed, clear-view batch bowl
- LiquiLock™ seal system holds liquids in bowl while processing and keeps the S-blade in bowl while pouring
- Includes: ½" slicing disc, ½" shredding disc, ⅝" grating disc and detachable disc stem
- Continuous-feed chute for large-volume processing (WFP14SC only)
- Easy on and off pulse control paddles
- 120V
- Limited 5 year motor and 2 year parts and labor warranty



- WFP11S 2½ qt Capacity
- WFP14S 3½ qt Capacity
- WFP14SC 3½ qt Capacity, Continuous Feed Chute



## Food Processors

- 4-quart batch bowl for processing soups, sauces, dressings and more with ease
- 2 hp peak input commercial motor
- Heavy-duty die cast housing
- Includes: sealed S-blade, adjustable slicing disc, reversible shredding disc, sealed whipping disc, WFP16SCD also includes a dicing assembly
- 120V, NEMA 5-15 P
- 5 year motor, 2 year parts and labor warranty



- WFP16S Sealed Batch Bowl
- WFP16SCD Combination Batch Bowl/Continuous Feed



## Quik Stik® Immersion Blender

- 2 speed control - light duty
- High efficiency motor
- All-purpose stainless steel blade
- Lightweight and compact
- 4½" w x 4½" d x 16" h
- 1 year limited warranty



WSB33X 12 qt Capacity, 7" Fixed Shaft



## Quik Stik Plus® Immersion Blender

- 2 speed control – for medium-duty mixing
- Lightweight and ergonomic – rubberized grip
- All purpose S/S blade
- 5" w x 5½" d x 22.4" h
- ½ hp motor, 350 watt, 120V
- 1 year limited warranty



WSB40 24 qt Capacity, 10" Fixed Shaft



### MX91 Master Mixer

- Mixes up to 60 liter/15 gal of cooked vegetables in under 3 minutes
- Titanium plated blade (non-detachable)
- Variable speed
- 16" S/S shaft
- 9,000 RPM, 460 watts
- 7½ lb, 28" long
- 115V

MX005.1



### PMX98 Senior Mixer

- Mixes up to 20 liter/5 gal of product at one time
- Titanium coated blade
- Perfect for soups, sauces and gravies
- Variable speed
- 12" S/S shaft
- 300 watts, 9,000 RPM
- 5 lb, 24" long
- 115V

MX007.1



### MD95 Mixer

- Mixes up to 8 liter/2 gal of product
- S/S, designed for smaller capacities of soup and sauces
- Equipped with safety switch
- Variable speed
- 7" shaft
- 2.6 lb, 17½" long
- 180 watts, 9500 RPM
- 115V

MX010.1



FOOD PREP



### Junior Standard Mixer

- Perfect for all soups, sauces, dressings and gravies
- Mixes up to 12 liter/3 gal of product
- 9" non-detachable stainless steel shaft
- Titanium coated blade for improved strength
- Option: variable speed
- 3 lb, 20" long
- 200 watts, 9000 RPM

MX020.1

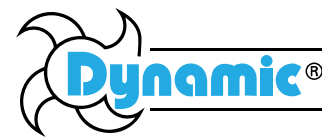

### MDH2000 Plus Combination Mixer

- Mixes up to 60 liter/15 gal of product
- 16" S/S detachable shaft with many attachments available
- Mixes, blends, purees or emulsifies
- Titanium coated blade
- Perfect for soups, pizza sauce, pasta sauce, salad dressing, refried beans, salsa and gravy
- Variable speed
- 8 lb, 30" long
- 9000 RPM

MX003.1



### Optional Attachments:

**AC003/F90, Whisk:** Whisks and blends to add air to the product. Great for dairy products, eggs, egg whites, meringue, soufflés, creams, fish and pancake batters. (5 gal capacity with 10" S/S tines, 900 RPM, 2 lb)

**FM Whips:** Master Whip available in 16½", 24" and 28". Great for dairy products, mayonnaise and for stirring sauces.

**AC004, Foodmill/Ricer:** Ricer tool (food mill). Perfect for mashed potatoes, steamed vegetables, puree. (50 lb cap, 17" long, 600 RPM)

**AC055, Dynacutter Bowl:** Dynacutter food processor bowl (no liquid necessary). Same applications as regular mixer tool in a smaller volume, plus non-liquid products such as nuts, raw vegetables and parsley. (6 qt S/S mixing bowl)

# FOOD PREP

## Mini Series MiniPro Mixer

- Mixes up to 1 gallon
- Light and efficient with a detachable foot
- Simple and easy maintenance
- Interchangeable attachments
- Accessories (included): 1 emulsifying cutter blade, 1 standard cutter blade, 1 batter blade, 1 dairy blade

MX070.1 7" Detachable Shaft

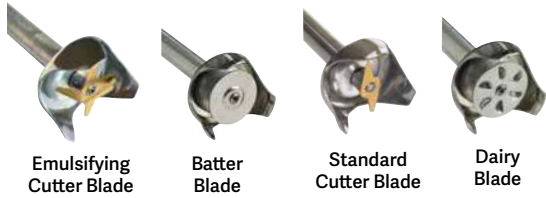

## Heavy-Duty Mixers

- Mix, blend, puree or emulsify
- Stainless steel shaft
- Titanium plated cutter blade
- Safety switch
- 115V
- 1 year parts and labor warranty

MX042.1ES



	Model	Capacity	Shaft	Weight	Watts
MX004.1	--	25 gal	16"	8 lb	460
<b>SMX Series Pro Mixers</b>					
MX002.1ES	SMX650ES	50 gal	21"	13.6 lb	650
MX040.1ES	SMX750ES	60 gal	24"	14.3 lb	750
MX001.1ES	SMX850ES	75 gal	27"	14.8 lb	850
MX041.1ES	SMX250ES	10 gal	12"	11 lb	600
MX042.1ES	SMX350ES	20 gal	14"	12.1 lb	600
MX043.1ES	SMX450ES	30 gal	16"	12.6 lb	600
MX044.1ES	SMX550ES	40 gal	18"	13 lb	600



## DynaCube Manual Dicer

- Patented stainless steel cutting grid system assures a clean, safe and efficient dice
- Dices vegetables, fruit and cooked meat
- Available blade sizes: 1/8", 1/4", 3/8", 1/2" and 3/4"

DC3 18"l x 19"w x 13"h Unfolded

5 grids available, includes your choice of 1 grid set

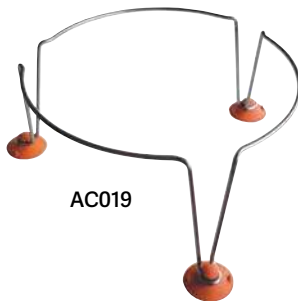

AC019



## Electric Salad Spinner

- Dries up to 8 heads of lettuce in less than 1 minute
- Equipped with a pulse function button and timer
- Double insulated motor
- Stabilizing base included
- 17" dia x 25"h
- 115V or 230V, 500 RPM
- 1 year warranty

E003.1.B.T EM98, 5 gal/20 liter Capacity



## Manual Salad Spinners

- Gears are made of the most durable plastic formula available
- Easy gear replacement
- 1 year warranty (includes gears)

Dries up to 8 Heads of Lettuce

E004 SD92SC, 5 gal/20 liter Capacity with Sealed Gears for Improved Sanitation

E002 SD92, 5 gal/20 liter Capacity

Dries up to 4 Heads of Lettuce

E001 SD99, 2 1/2 gal/10 liter Capacity

AC019 SSB-1, Salad Spinner Base; For SD92 & SD925C Only

Dries up to 2 Heads of Lettuce

E007 SDMINISC, 1 1/4 gal/5 Liter Capacity

## Pineapple Corer

- Peels, slices & cores at the same time
- Corkscrew style operation
- Removes rings while leaving shell intact
- Stainless steel w/textured handle

CTR-PINE



## Citrus Wedgers

- Heavy-duty aluminum construction
- Stainless steel blades

CTR-WED6 6 Section  
CTR-WED8 8 Section



**FOCUS**  
FOODSERVICE  
A CROWN BRANDS COMPANY

NSF

97306

97332

## Commercial Juice Presses

- Constructed of ultra-strong cast iron
- Enamel coating resists citrus acids, pitting and corrosion
- Sure grip rubber handles are easy to hold and use
- Wide base and rubber suction cup feet for safe operation
- Each unit comes in a trilingual full color box
- 1 year warranty

### OLYMPUS™

9¼"l x 7⅜"w, 31"h

w/Handle Upright

97302

White

97306

Black

### JUPITER™

8¾"l x 7¼"w, 27½"h

w/Handle Upright

97332

White

97336

Black

## Manual Salad Spinners

- Innovative, patented Braking System protects and increases the life of the gears (except 90008)
- Sealed watertight gearbox (except 90008)
- Convenient side handles

- Comfortable finger grip handle on the crank
- Heavy-duty, FDA approved plastic



PROFESSIONAL

90012‡ 2.5 gallon - 2 to 3 Heads of Lettuce

90005‡ 5 gallon - 5 to 6 Heads of Lettuce

90008 Economy, 5 gallon - 5 to 6 Heads of Lettuce

‡ ETL approved



90008

## High Output Commercial Citrus Juicers

- High power - 1800 RPM motor
- High output - for continuous juicing
- 3 easy to change cones for all sizes of citrus
- Surgical stainless steel bowl with pulp strainer
- Easy to clean splash guard
- Long-lasting cast aluminum housing with chrome finish
- 1 year commercial warranty
- Approved to UL, CSA and NSF standards by ETL

JUC-100 8¼" dia x 13¼"h

JUC-200 10" dia x 15¼"h



# FOOD PREP



NSF

## Easy FryKutter™

- Short throw handle and superior engineering improves leverage for smooth, easy cutting or wedging
- Built to last under the toughest day-to-day conditions
- Slide-in, slide-out wall bracket (sold separately) fits the same mounting holes as most other machines

55450-1	¼" Cut	55450-4	4 Section Wedger
55450-2	⅜" Cut	55450-6	6 Section Wedger
55450-3	½" Cut	55450-8	8 Section Wedger



NSF

## Easy Tomato Slicer™

- Compact size saves valuable work space
- Razor-sharp S/S blades cut with trouble free precision
- Vertical handle and protective guards
- High-density polyethylene slide board

55600-1	⅜" Slice	55600-3	⅝" Slice
55600-2	¼" Slice	55600-7	½" Slice

## Easy Chopper™

- Comfortable, weighted handle does most of the work
- One cutting grid included
- Interchangeable cutting grids (sold separately) cut, chop and dice easily
- Stainless steel grid blades stay sharp to cut cleanly with one stroke
- Sturdy base is well balanced on four legs with non-skid feet

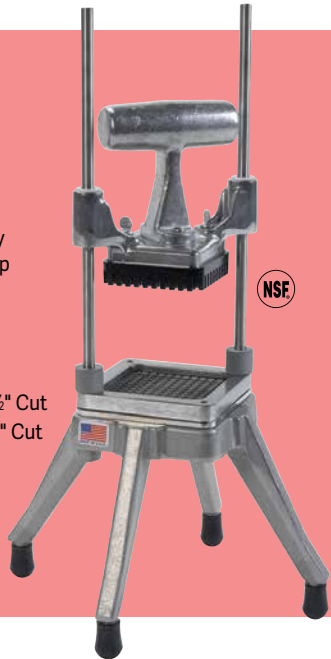

NSF

55500-1	¼" Cut	55500-3	½" Cut
55500-2	⅜" Cut	55500-4	1" Cut

**nemco**® FOOD EQUIPMENT

**nemco**® FOOD EQUIPMENT



NSF

## Easy Tomato Slicer 2™

- Pretensioned cartridge blade assembly stays properly aligned and tightened
- Holds larger tomatoes, 4½" diameter
- Also cuts strawberries and mushrooms
- Features ergonomic handle, high density polyethylene slide board, hand guards, self-lubricating track, and rubber feet

56600-1	⅜" Slice
56600-2	¼" Slice
56600-3	⅝" Slice

## Easy-Slicer™ Vegetable Slicer

- Unique, adjustable, S/S blade provides a full range of slicing options, from ⅛" to ½"
- Turn the thumbscrew to lock the setting on the calibrated gauge
- Fixed blade units also available
- Optional portable suction cup mounting base

55200AN	Slicer
55816	Optional Base

NSF



55200AN

55816







### Mandoline Slicer

- Stainless steel construction
- Ergonomic soft-grip black handle
- ABS rotary adjustment dial and built-in blades
- Non-skid folding legs
- Includes stainless steel pusher

MS-SS



CTR-TS14

### Tomato Slicers

- Commercial-grade aluminum
- Stainless steel blade sets
- Non-slip base
- Razor-sharp blades for even slicing without bruising

CTR-TS14 1/4" Cut  
CTR-TS316 3/16" Cut

### Vegetable Dicers

- Aluminum elevated base
- Stainless steel blade assemblies
- Clean, sharp and quick dicing
- Rubber feet keep dicer securely in place
- Reduces prep time for onions, tomatoes, potatoes, celery etc.

CTR-VD1 1/4"  
CTR-VD2 3/8"



CTR-VD2



### Easy Chopper 3™

- For chopping, slicing and wedging
- Weighted ergonomic handle, aluminum construction and high-tension stainless-steel blades
- Color-coded blade assemblies and push blocks
- Revolutionary push-block "gaskets" reduce cleaning
- Push block's nylon based resin is highly resilient
- Large base allows chopped produce to fall straight into a 1/6 or 1/8 size food pan



57500-1



57500-1 1/4" Sq. Cut  
57500-2 3/8" Sq. Cut  
57500-3 1/2" Sq. Cut  
57500-4 1" Sq. Cut  
57500-5 1/4" Thick Slice  
57500-6 3/8" Thick Slice  
57500-7 1/2" Thick Slice

nemco® | FOOD EQUIPMENT



### Kattex Adjustable Fruit & Vegetable Slicer

- Aluminum construction with 9 1/4" stainless steel adjustable blade
- Mounts to counter tops and other flat surfaces and can easily be removed for storage and cleaning
- 1/16" to 1/2" slice thickness

FVS-1 9 1/4" Blade

HCD-250BK

### Kattex Choppers/Dicers

- Aluminum construction with stainless steel wire blades
- Sturdy base with non-skid feet

#### Choppers/Dicers

HCD-250 1/4"  
HCD-375 3/8"  
HCD-500 1/2"  
Replacement Blade & Block  
HCD-250BK 1/4"  
HCD-375BK 3/8"  
HCD-500BK 1/2"

HCD-250



# KITCHEN

## Genesis® Cutlery

- High carbon, German steel from tip to tang resists rust, stains, and discoloration
- One-piece, fully forged construction ensures superior balance, strength, and durability
- Razor-sharp edge is taper ground with a fine stone finish
- Limited lifetime warranty



Santoprene® handle provides a soft, confident grip for comfort and safety

- M21052 Peeling, 3"
- M20003 Paring, 3½"
- M20405 Utility, 5"
- M20106 Boning, Stiff, 6"
- M20206 Boning, Flexible, 6"
- M20307 Fillet, Flexible, 7"
- M20707 Santoku, Granton Edge, 7"

- M20907 Nakiri, 7"
- M21067 Nakiri, Granton Edge, 7"
- M20608 Chef's, 8"
- M20610 Chef's, 10"
- M21078 Chef's, Short Bolster, 8"
- M21079 Chef's, Short Bolster, 9"
- M21080 Chef's, Short Bolster, 10"

- M20508 Bread, Wavy Edge, 8"
- M20408 Carving, 8"
- M20410 Carving, 10"
- M21030 Carving, Granton Edge, 10"
- M20806 Carving Fork, 6"
- M21046 Straight Fork, 7"
- M21010 Sharpening Steel, 10"

## Renaissance® Cutlery

- One-piece, fully forged construction provides remarkable balance (M23720 & M23710 have a one-piece, stamped three quarter tang blade)
- High carbon, German steel from tip to tang resists rust, stains and discoloration
- Shortened bolster for easy sharpening
- Razor-sharp edge is taper ground with a fine stone finish
- Limited lifetime warranty



- M23640 Peeling, 3"
- M23540 Paring, 3½"
- M23600 Utility, 5"
- M23610 Tomato, 5"
- M23550 Boning, Stiff, 6"
- M23560 Boning, Flexible, 6"
- M23630 Fillet, 7"
- M23590 Santoku, Granton Edge, 7"

- M23660 Nakiri, 7"
- M23510 Chef's, 8"
- M23530 Chef's, 10"
- M23580 Carving, 10"
- M23570 Bread, Wavy Edge, 8"
- M23710 Slicer, Wavy Edge, 11"
- M23720 Slicer, Granton Edge, 11"
- M23620 Fork, 6"



Ergonomically designed Delrin® handle has three rivets

## Millennia® Cutlery

- Stain-free, high-carbon Japanese steel
- Ergonomic knife handle features a unique combination of Santoprene® for comfort and polypropylene for tough use
- Handle features textured finger points and protective finger guard
- Limited lifetime warranty



NSF



## Millennia® Colors

- High-carbon, stain-free Japanese steel
- Color-coded handles for dedicated use
- Ergonomic Santoprene® and Polypropylene handle provides comfort and anti-slip benefits
- Limited lifetime warranty
- Knives available Green (GR), Yellow (YL), Blue (BL), Brown (BR), Purple (PU) or Red (RD)

- M22102 Peeling, 2½"
- M23900P Paring, Slim, 3"
- M19901P Paring, Slim, Serrated, 3"
- M22003 Paring, 3½"
- M23306 Utility, 6"
- M23406 Utility, Wavy Edge, 6"
- M23408 Utility, Wavy Edge, 8"
- M22306 Boning, 6"
- M22206 Boning, Narrow, 6"
- M23850 Boning, Flexible, 6"
- M23810 Boning, Wide, 6"
- M23820 Boning, Curved, 6"
- M22807 Fillet, Flexible, 7"
- M23860 Fillet, Narrow, 8½"
- M22707 Santoku, Granton Edge, 7"
- M22907 Nakiri, 7"
- M22608 Chef's, 8"
- M22609 Chef's, 9"

\*Polypropylene Handle

- M22610 Chef's, 10"
- M22612 Chef's, 12"
- M22611 Chef's, Granton Edge, 10"
- M23830\* Chef's, Wavy Edge, 7½"
- M23831 Chef's, Wavy Edge, 10"
- M18000 Chef's, Wide, Hollow Ground, 8"
- M18010 Chef's, Wide, Hollow Ground, 10"
- M23011 Slicer, Granton Edge, 11"
- M13914 Slicer, Granton Edge, 14"
- M23111 Slicer, Wavy Edge, 11"
- M23112 Slicer, Wavy Edge, 12"
- M23870 Slicer, Plain Edge, 12"
- M23010 Salmon Slicer, Granton Edge, 10¼"
- M22508 Bread, Wavy Edge, 8"
- M23210 Bread, Wavy Edge, 10"
- M23880 Bread, Curved, Wavy Edge, 10"
- M22408 Offset Bread, Curved, Wavy Edge, 8"
- M23890 Offset Bread, Curved, Wavy Edge, 9"

- M23930 Paring, 3"
- M22206 Boning, Narrow, 6"
- M23820 Boning, Curved, 6"
- M22707 Santoku, Granton Edge, 7"
- M22418 Offset Bread-Wavy Edge, 8"
- M22608 Chef's, 8"
- M22610 Chef's, 10"

NSF



M23930GR



M22206YL



M23820BL



M22707BR



M22418PU



M22608BL



M22610RD

## ZüM® Cutlery

- One-piece precision forged construction
- High-carbon, no-stain German cutlery steel resists rust, corrosion, and discoloration
- Taper-ground edge allows for added stability, easy honing, long lasting sharpness, and increased efficiency
- Shortened bolster exposes full blade edge for easier sharpening

NSF

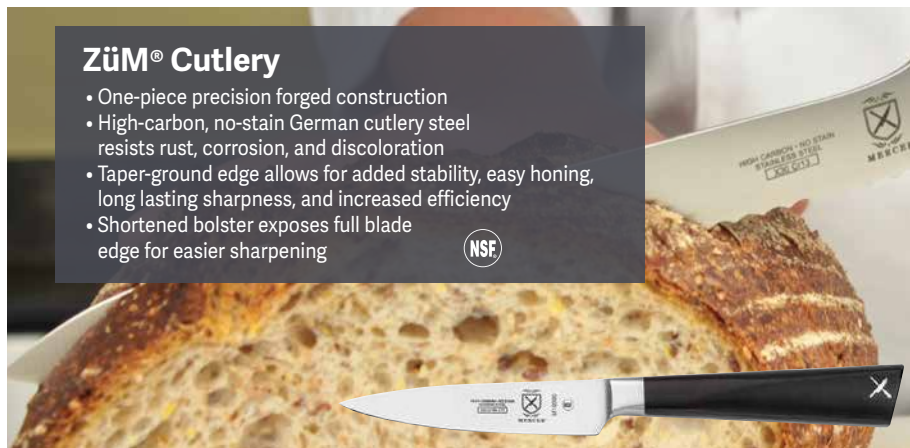

Modern handle design combines Eastern Japanese style with classic Western blade designs

- M19000 Paring, 3"
- M19020 Utility, Wavy Edge, 6"
- M19030 Boning, Stiff, 6"
- M19040 Fillet, 7"
- M19050 Santoku, Granton Edge, 7"
- M19080 Chef's, 8"
- M19090 Chef's, 9"

- M19010 Chef's, 10"
- M19060 Carving, 8"
- M19070 Bread, Wavy Edge, 8"
- M19015 Carving Fork, Curved, 6¼"

# KITCHEN

## Zwilling® KolorID

- High carbon, nitrogen enriched NO STAIN steel
- Precision-honed and laser controlled edge ensures ideal cutting angles for sharpness and durability
- Non-hydroscopic safe-grip (won't absorb liquids) molded polypropylene handle safe up to 212°F
- Each knife comes with 6 interchangeable color buttons to identify food preparation tasks to prevent cross-contamination
- Dishwasher safe
- Chef's Roll includes: 5" utility, 6" flex boning knife, 7" santoku knife, 8" chef's knife, 10" bread knife, 9" sharpening steel and 8 pocket case

33107-131	Utility Knife, 5"
33104-151	Boning Knife, 6"
33108-181	Hollow Edge Santoku Knife, 7"
33101-201	Chef's Knife, 8"
33101-251	Chef's Knife, 10"
33106-251	Pastry/Slicing Knife, 10"
33110-361	Hollow Edge Slicing Knife, 14"
33122-000	7 pc Chef's Roll Set

NSF

## Steak Knife Sets

- Ergonomic traditional triple-rivet handle—made from antibacterial polypropylene or beautiful pakka wood and chip resistant
- Full tang provides perfect balance and strength
- Stainless steel blade is anti-corrosion and chip resistant

35315-000	24 pc, Black Poly Handle, Fine Edge
35318-000	24 pc, Black Poly Handle, Serrated Edge
35322-000	24 pc, Dark Brown Pakka Handle, Fine Edge
32525-261	10" Diamond Sharpening Steel

## \*\*\*\*Four Star®

- High carbon NO STAIN steel
- Precision-honed blade and laser-controlled edge ensures ideal cutting angle for sharpness and durability
- Ergonomic polypropylene handles
- Chef's Roll includes: 9" sharpening steel, 8" chef's knife, 8" bread knife, 5½" prep knife, 4" paring knife and deluxe 13 pocket case

31070-053	Peeling Knife, Bird's Beak, 2¾"
31070-103	Paring Knife, 4"
31086-143	Boning Knife, Flexible, 5½"
31098-183	Santoku Knife, Hollow Edge Rocking, 7"
31071-203	Chef's Knife, 8"
31071-263	Chef's Knife, 10"
35168-006	6 pc Chef's Roll Set

31070-103
31070-053
31071-203
31071-263

## Sharpening Steels

- Plastic handles



- A. Diamond Sharpening Steels**  
 7.8991.14 Oval, Economy Hollow Core, 10"  
 7.8991.15 Oval, Economy Hollow Core, 12"

- B. Sharpening Steel**  
 7.8991.6 Round, Regular Cut, 12"



## Black Fibrox® Pro Cutlery

- Hand finished blades are high carbon stainless steel with taper ground, beveled edges
- Tempered for a superior edge
- Lifetime guarantee
- Ergonomic handles

- |           |   |
|-----------|---|
| 5.0603.S  | Paring, 3¼"                             |
| 5.0633.S  | Paring, 3¼"                             |
| 5.0703.S  | Paring, 4"                              |
| 5.2523.17 | Santoku, Granton Edge, 7"               |
| 5.2063.20 | Chef's, 8"                              |
| 5.2003.25 | Chef's, 10"                             |
| 5.7303.25 | Cimeter Knife, 10"                      |
| 5.2533.21 | Bread, 8"                               |
| 5.2933.26 | Bread, 10¼"                             |
| 5.2033.25 | Sandwich Knife, Wavy Edge, 10"          |
| 7.6058.13 | Bread/Deli Knife, Offset, Wavy Edge, 9" |
| 5.4233.25 | Slicer, Wavy Edge, 10"                  |
| 5.4723.30 | Slicer, Granton Edge, 12"               |

## Rosewood Handle Cutlery

- High carbon stainless steel blades with taper ground & beveled edges
- One piece natural rosewood handles are ergonomically designed



- |           |                           |
|-----------|---------------------------|
| 6.8520.17 | Santoku, Granton Edge, 7" |
| 5.2060.20 | Chef's, 8"                |
| 5.2000.25 | Chef's, 10"               |
| 5.1630.21 | Bread, 8"                 |
| 5.2930.26 | Bread, 10¼"               |
| 7.6059.11 | Slicer, 12"               |



# KITCHEN

KSTK-30

KSTK-80

KSTK-60

KSTK-82

KSTK-91

KSTK-31

KSTK-100

KSTK-61

KSTK-103

KSTK-92

KSTK-122

KSTK-50

KSTK-70

KSTK-62

KSTK-102

KSTK-121

KSTK-140

### Sof-Tek™ Soft Grip Cutlery

- Razor-sharp X50 Cr Mo V15 German steel blade
- The comfortable soft-touch, non-slip handle helps to reduce arm and hand fatigue
- Black and blue handle
- Easy edge maintenance and rapid sharpening

KSTK-30	Paring, 3¼"	KSTK-82	Filet, Flexible, 8"
KSTK-31	Paring, Serrated, 3½"	KSTK-103	Cimeter, Hollow Ground, 10"
KSTK-50	Utility, Serrated, 5½"	KSTK-102	Bread/Pastry, Wide, 10"
KSTK-80	Chef's, Wide, 8"	KSTK-91	Bread, Wavy Edge, 9½"
KSTK-100	Chef's, Wide, 10"	KSTK-92	Offset Bread, Utility, 9"
KSTK-70	Santoku, 7"	KSTK-121	Slicer, Wavy Edge, 12"
KSTK-60	Boning, Curved, 6"	KSTK-122	Slicer, 12"
KSTK-61	Boning, Narrow, 6"	KSTK-140	Slicer, Hollow Ground, Wide, 14"
KSTK-62	Boning, Wide, 6"		

# KITCHEN



## Statik Board™ Cutting Boards

- Full color boards to enhance your HACCP color-coded system
- Non-slip feet
- Fully rubberized grip hook
- Built-in hanging hook
- BPA free
- Specify Brown (BN), Blue (BU), Green (GR), Red (RD) or Yellow (YL)

CBK-1218	12" x 18"
CBK-1520	15" x 20"
CBK-1824	18" x 24"



## Statik Board™ Cutting Boards

- White boards with colored non-slip grips and hook
- HACCP color-coding system to minimize cross-contact
- Built-in hook for easy transport and hygienic storage
- Rubberized feet grip flat surfaces, rubberized sides keep the board upright without sliding
- Tough board surface reduces knife dulling, durable copolymer prevents warping
- Dishwasher safe
- Specify Brown (BN), Blue (BU), Green (GR), Red (RD), White (WT), Purple (PP) or Yellow (YL)

CBN-1218	12" x 18"
CBN-1520	15" x 20"
CBN-1824	18" x 24"



CBN1824

### Statik Board™ Garnish Cutting Board

- Non-slip feet
- Fully rubberized grip hook
- Built-in hanging hook
- White
- BPA free

CBN-610WT 6" x 10"

## Platinum Commercial Series Wood Cutting Boards

- 1¾" Northern hard rock maple
- Premium foodservice quality
- ¼" radius edges
- Reversible with recessed finer grips
- Edge grain construction
- Boos Block® antimicrobial cream with beeswax finish



R1812

R1812	18" x 12"
R2015	20" x 15"
R2418	24" x 18"



CBG121812



## Saf-T-Grip® Color Cutting Boards

- Integrated anti-slip grips hold board in place
- Embossed ruler feature makes portioning easy, saving money and time
- Food safety hook for sanitary transport and storage
- Dishwasher safe
- Colors for HACCP safe food handling
- ½" thick
- Colors include White (WH), Red (RD), Green (GN), Yellow (YL), Brown (BR) and Blue (BL)

### Saf-T-Grip® 6-Board Cutting Board Systems

- Set of six includes (1 ea) Red, Yellow, Green, Blue, Brown and White cutting boards

### Saf-T-Grip Boards

CBG121812*	12" x 18"
CBG152012*	15" x 20"
CBG182412*	18" x 24"

\*Specify desired color

### 6-Board

### Cutting Board Systems

CBG1218KC	12" x 18"
CBG1520KC	15" x 20"
CBG1824KC	18" x 24"



## Puzzle Boards

- Designed to break down and fit into dishwashers, then puzzle back together to create a prep surface large enough for commercial kitchens
- Knife friendly, non-porous surface is resistant to bacteria and maintenance-free
- Heat resistant to 350°F
- Dishwasher safe
- 3/8" thick

**epicurean**

By Victorinox



629-481001	48" x 10" x 3/8"
629-601001	60" x 10" x 3/8"
629-721001	72" x 10" x 3/8"
629-932001	93" x 20", 5 Pieces, Custom Size Boards in 3/8" and 1/2" Thickness and Natural Color are Available

### Sheet Pan Board

629-241601	24 1/2" x 16 1/2", Fits Inside of Standard Size Sheet Pan
------------	---

### Standard Cutting Boards

629-141101	14" x 11" x 3/8"
629-191501	19" x 15" x 3/8"

Ready to learn more about these great products?

**PLAY VIDEO**

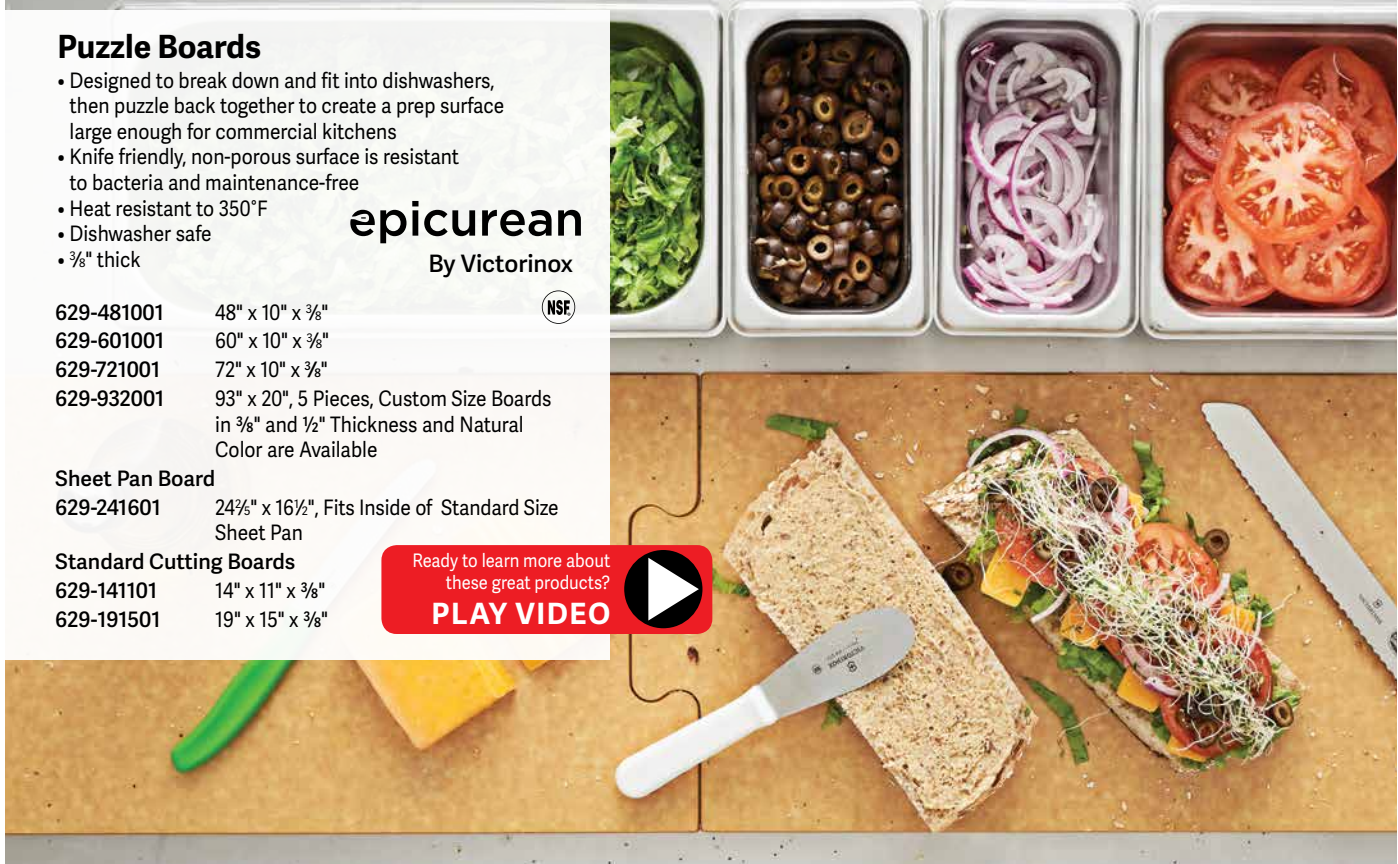

**KITCHEN**



## PerformanceSHIELD2 Cut Resistant Gloves

- Designed specifically for foodservice cutlery
- With durable Spectra™ industrial polyester for durability, comfort and exceptional cut resistance
- Built-in antimicrobial protection
- Washable and bleach safe
- Ambidextrous
- White



**VICTORINOX**  
SWISS ARMY

7.9049.XS	X-Small
7.9049.S	Small
7.9049.M	Medium
7.9049.L	Large
7.9049.XL	X-Large



## Knife Sharpener

- Tungsten carbide blade
- Black

7.8715



**VICTORINOX**  
SWISS ARMY

## Stainless Steel Protective Mesh Gloves

- Made for meat processing
- Reversible
- Light weight and non-corrosive
- Protect hands from cuts and punctures while deboning and butchering

PMG-1S	Small, White Strap
PMG-1M	Medium, Red Strap
PMG-1L	Large, Blue Strap

**Winco**®



# KITCHEN



## Saf-T-Knife® Station

- Sanitary, safe and secure storage for kitchen knives
- Easy to disassemble and clean
- Protects knives from contamination and accidents
- Dishwasher safe
- Clear view door for easy knife identification

STK1008

Holds up to 8 Knives & Sharpener



## D-Shield™ Cut Resistant Gloves

- 10 gauge Dyneema® fiber
- Ambidextrous
- Machine washable

DFG1000-S	Small
DFG1000-M	Medium
DFG1000-L	Large
DFG1000-XL	Extra Large



ANSI Level A4 cut protection



## Four-Stage Knife Sharpener

- For either standard or Asian style knives, coarse stages quickly sharpen dull knives, while fine stages hone to a razor sharp edge
- Reduced wobbling - the safest sharpener with oversized non-slip base
- Most ergonomic handle available for comfort, slip-resistance and grip control

KSP-4



← Rubber, non-slip base

## Knife Sharpener

- Manual pull through
- Ceramic rods in both coarse and fine grits
- Gray

32602-000



ZWILLING  
J.A.HENCKELS



## Knife Block Set

- Sturdy beechwood protects knives from damage and dulling
- Holds up to 12 knives—6 blades up to 5" and 6 up to 10"

35160-000

## Magnetic Knife Bar

- Plastic
- Black finish
- Wall-mounted



32621-450

17½" long



## Manual Diamond Hone® Knife Sharpeners

- Uses 100% diamond abrasives
- Patented precision guides for sharper edges with no guesswork
- Assembled and engineered in USA

- M430 Serrated Edge Only  
 M450 Straight Edge Only, 2 Stage  
 M460 Straight & Serrated Edges, 2 Stage



**Chef'sChoice**



## Pronto® Manual Diamond Hone® Knife Sharpener

- Sharpens straight and serrated knives
- Precise bevel angle control for a 20° edge
- Comfortable non-slip handle & rubber feet
- Fastest manual sharpener in the industry
- Assembled and engineered in USA

M465 Straight and Serrated Edges, 2 Stage



## Diamond Hone® Compact Knife Sharpener

- Quickly and easily sharpen a wide variety of knives, tools and sports accessories
- Precision guides
- 100% diamond abrasives
- Assembled and engineered in the USA

M480KC Straight Edge Only, 2 Stage

## EdgeSelect-Pro™ Electric Knife Sharpener

- Incorporates 100% diamond abrasives
- Rugged cast metal construction
- Uses stropping technology for a sharper and finer blade
- Quickly and easily sharpens straight and serrated edge knives
- 1 year limited warranty
- Assembled and engineered in the USA



M125 Straight and Serrated Edges, 3 Stage

## Sharp-n-Hone® Electric Knife Sharpener

- Incorporates 100% diamond abrasive disks and revolutionary flexible polymer stropping disks to sharpen and polish all straight edge and serrated knives
- Built-in precision angle guides
- 4½" w x 8⅜" l x 4" h
- Assembled and engineered in the USA



M325 Straight and Serrated Edges, 2 Stage

## Commercial Diamond Hone® Electric Sharpeners

- Lightning fast with diamond abrasives and ultra fine honing disks for hairsplitting sharpness in seconds
- Both models use proprietary stropping disks for razor sharp edges that stay sharp longer
- Sharpens both straight and serrated knives
- Rugged sharpening module detaches for cleaning in a sink or dishwasher
- Precision angle guides eliminate guesswork
- Safe for all alloys—never detempers
- Powerful motor
- Assembled and engineered in the USA

- Knife Sharpeners  
 M2000 2 Stage  
 M2100 3 Stage

- Replacement Modules  
 M2050 Sharpening Module for M2000  
 M2130 15° Sharpening Module for M2100  
 M2150 20° Sharpening Module for M2100  
 M2170 Ceramic Knife Sharpening Module for M2100



**Chef'sChoice**

M2100



KITCHEN

# KITCHEN

## Portion Control Dishers

- Comfortable squeeze control for left or right hand
- Gear mechanism - no springs to lose or replace
- Color-coded and marked for easy portion identification
- Ideal for portioning chicken or tuna salads, mashed potatoes, etc.

	Color	Size	Capacity
947400	Orchid	40	0.8 oz
947398	Black	30	1.07 oz
947397	Red	24	1.33 oz
947396	Yellow	20	1.6 oz
947395	Royal Blue	16	2 oz
947393	Green	12	2.67 oz
947392	Ivory	10	3.2 oz
947391	Gray	8	4 oz
947390	White	6	5.33 oz



## Hell's Tools® Kitchen Utensils

- Made from specially formulated glass-reinforced nylon to provide heat resistance up to 430°F
- One-piece construction is incredibly durable
- Stain and odor resistant
- Mixing Spoon is available in Blue (BL), Brown (BR), Green (GR), Purple (PU), Red (RD), Black (BK), Yellow (YL), White (WH) and Tan (TN)
- Utility Tongs are available in Blue (BL), Brown (BR), Green (GR), Red (RD), Black (BK), Yellow (YL), White (WH) and Purple (PU)
- Slotted Spatula is available in Blue (BL), Brown (BR), Purple (PU), Red (RD), Black (BK), Green (GN), Yellow (YL), White (WH) and Gray (GY)
- Spootensils® are available in White

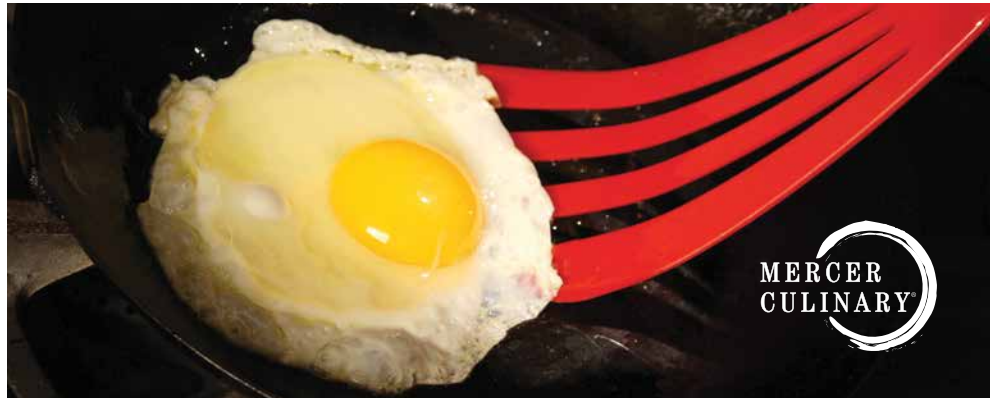

- A. M33182 11 1/8" Mixing Spoon
- B. M35100 9 1/2" Utility Tongs
- C. M35110 12" Slotted Spatula
- D. M35120 9 7/8" Spootensil®
- M35121 11 1/8" Spootensil®
- M35122 13 3/4" Spootensil®
- M35123 15 1/4" Spootensil®
- M35124 17 1/4" Spootensil®
- M35125 19 1/4" Spootensil®

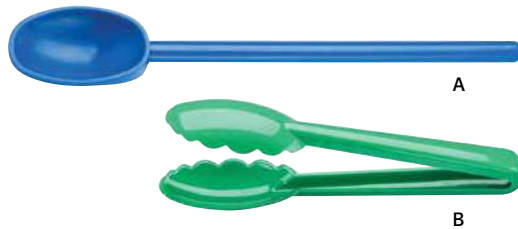

## Hell's Handle® Utensils

- High heat resistant - withstands temperatures up to 450°F
- Remains cool to the touch longer
- Dual-textured finish on handle for extra grip and slip resistance
- Professional quality stainless steel blades

M18340	5" x 3" Heavy-Duty Turner	M18310	8" x 3" Turner-Perforated
M18280	5" x 4" Heavy-Duty Turner	M18330	8" x 3" Long Handled Turner
M18290	6" x 5" Heavy-Duty Turner	M33183	6" x 3" Fish Turner
M18350	8" x 4" Heavy-Duty Turner	M18390	9" x 4" Large Fish Turner
M18320	6" x 3" Square Edge Turner	M18380	8" Cook's Fork
M18360	8" x 3" Square Edge Turner	M18270	4 1/2" x 4" Grill Scraper
M18300	8" x 3" Turner	M18370	6" x 3 1/2" Bench Scraper/Ruler





### Magnetic Spoon Set

- Stainless steel, magnetic handles keep sets nested together
- Non-stick finish and reversible heads — one for liquid, one for dry



8942      tbsp, 1 tsp, 1/2 tsp, 1/4 tsp

### Spring Tongs w/ Silicone Tips

- Heavy-duty stainless steel tongs can be lock-closed
- Molded silicone tips are heat resistant and will not trap food particles
- Non-slip handles and hanging loop



STS-9HD    9" long  
STS-12HD   12" long



### Ergo Utensils

- 18/8 stainless steel
- Ergonomic contoured handles are made from non-slip Santoprene® thermal plastic
- No hidden crevices in the handle to capture food particles

538BKDC    6 1/4" "Y" Peeler  
536BKDC    7 1/2" Swivel Peeler  
539BKDC    10" Cheese Grater



### Portion Control Spoons

- Unique bowl design reduces food waste and contributes to portion control
- Ergonomic handles have hanging hook and hole and feature a pan stop
- Stainless steel, color coded and laser etched for easy size identification

Solid	Perforated	Capacity	Color
947352	947362	2 oz	Blue
947353	947363	3 oz	Beige
947354	947364	4 oz	Gray
947356	947366	6 oz	Black
947358	947368	8 oz	Red

### Commercial Egg Slicer

- Makes round, oval or wedge-shaped slices
- Zinc die cast body for incredible strength
- Extra thick stainless steel cutting wires
- Nylon base with silicone non-skid feet
- Replaceable wire harness

FESW      4 1/2" x 3 3/4" x 1 1/2" h



# KITCHEN

## NSF® InvertaTop™ Squeeze Bottles

- Invertatop™ dual openings make dispensing, cleaning and filling easy
- Soft, leak-proof PerfectFlex™ design is operator friendly, while reducing waste and ensuring faster prep time
- ValveTop™ design works with fast flow and slow liquids, sauces and condiments, also allows for small particles up to 1/8"
- Easy-to-clean ValveTop™



- 12SV 12 oz Dispenser, 53mm Opening
- 16SV 16 oz Dispenser, 53mm Opening
- 24SV 24 oz Dispenser, 63mm Opening
- 32SV 32 oz Dispenser, 63mm Opening



## The High-Volume Press-O-Matic

- Maximize efficiency with your daily condiment prep
- Users can fill squeeze bottles and ramekins quickly
- Durable, stainless steel housing
- Dispenser lever is ergonomically designed for effortless use
- Discharge spouts with integrated connectors can stay attached to their pouches and still maintain a seal for optimum product freshness

10975 1.5 gallon Pouch, 18" x 10" x 17" OA



**nemco**  
powered by **ASEPT**



## Bun Pans

- Wire reinforced rim with 1" edge
- 19 gauge aluminum

- ABNP-13 Eighth Size, 6" x 10"
- ABNP-25 Fourth Size, 9½" x 13"



## Sheet Pans

- 3003 aluminum
- Closed bead pans are reinforced with galvanized wire for rust resistance

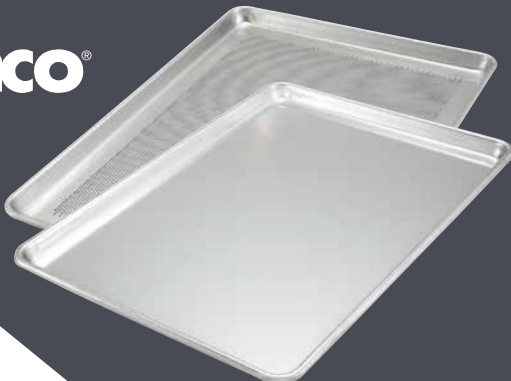

Solid Pans	Pan Size	Dimensions	Bead	Gauge
ALXP-0609	Eighth	6" x 9"	Open	16
ALXP-1013	Quarter	9½" x 13"	Closed	20
ALXP-1310H	Quarter	10" x 13"	Closed	18
ALXP-1318	Half	13" x 18"	Closed	20
ALXP-1813H	Half	13" x 18"	Closed	18
ALXP-1622	Two-Thirds	16" x 22"	Closed	19
ALXP-2216H	Two-Thirds	16" x 22"	Closed	18
ALXP-1826	Full	18" x 26"	Closed	18
ALXP-2618H	Full	18" x 26"	Closed	16
ALXP-1200^	Full	18" x 26"	Open	12
Perforated Pans				
ALXP-1318P	Half	13" x 18"	Closed	18
ALXP-1826P	Full	18" x 26"	Closed	18
ALXP-2618P	Full	18" x 26"	Closed	16

^NSF



## Sheet Pans & Covers

- Concave bottoms flatten during heating
- Reinforcing rods keep pans straight

### Plastic Sheet Pan Covers

- Dishwasher safe polypropylene
- Snap-on fit
- Fits most standard aluminum sheet and display pans



### Sheet Pans

- 900800 Full Size, Aluminum
  - 900850 Half Size, Aluminum
  - 900450\* Quarter Size, Aluminized Steel
- \*Not NSF

### Sheet Pan Covers

- 90PSPCFL Full Size
- 90PSPCHF Half Size
- 90PSPCQT Quarter Size

## Muffin & Roll Pans

- Aluminized steel with silicone glaze coating

### Jumbo Muffin Pan

- Cups are 7 oz to brim

905285 3<sup>3</sup>/<sub>8</sub>" Top dia, 24 Cup

### Large Crown Muffin Pan

- Cups are 7.3 oz to brim

903555 3<sup>1</sup>/<sub>2</sub>" Top dia, 12 Cup

### Pecan Roll Pan

- Cups are 8.2 oz to brim

903695 3<sup>1</sup>/<sub>16</sub>" Top dia, 12 Cup

### Mini-Muffin Pan

- Cups are 2.1 oz to brim

905245 2<sup>1</sup>/<sub>16</sub>" Top dia, 24 Cup

### Cupcake/Muffin Pans

- Cups are 3.8 oz to brim

905045 2<sup>3</sup>/<sub>4</sub>" Top dia, 12 Cup

905525 2<sup>3</sup>/<sub>4</sub>" Top dia, 24 Cup

905575 2<sup>3</sup>/<sub>4</sub>" Top dia, 35 Cup



## Round Cake Pans

- Aluminized steel construction with silicone glaze
- Rolled edge
- 2" h

907026 7" dia

900825 8" dia

909025 9" dia

901025 10" dia



KITCHEN

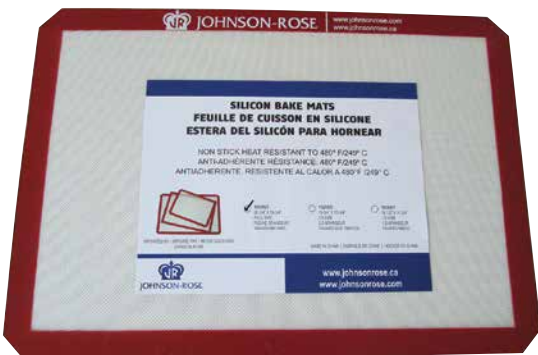

← Reusable 2000 to 3000 times

## Silicone Bake Mats

- Non-stick
- Made to fit bun pans
- Temperature range of -40° to 480°F



SFBM-100  
10265

Full Size, 24<sup>1</sup>/<sub>2</sub>" x 16<sup>1</sup>/<sub>2</sub>"  
Two-Thirds Size, 19<sup>3</sup>/<sub>4</sub>" x 13<sup>3</sup>/<sub>4</sub>"

# KITCHEN



## Standard Mixing Bowls

- Stainless steel
- Polished interior and exterior

ROY MIXBL 75	¾ qt	ROY MIXBL 5	5 qt
ROY MIXBL 15	1½ qt	ROY MIXBL 8	8 qt
ROY MIXBL 3	3 qt	ROY MIXBL 13	13 qt
ROY MIXBL 4	4 qt	ROY MIXBL 20	20 qt



## Pastry Bag Tips

• 304 stainless steel

Plain	Star	
PST 0 PL	PST 0 ST	Size 0
PST 1 PL	PST 1 ST	Size 1
PST 2 PL	PST 2 ST	Size 2
PST 3 PL	PST 3 ST	Size 3
PST 4 PL	PST 4 ST	Size 4
PST 5 PL	PST 5 ST	Size 5
PST 6 PL	PST 6 ST	Size 6
PST 7 PL	PST 7 ST	Size 7
PST 8 PL	PST 8 ST	Size 8
PST 9 PL	PST 9 ST	Size 9



PLAIN



STAR



## Rotary Flour Sifter

- Fine mesh stainless steel

ROY RFS 8 Cup

## Dough/Proofing Pans

- Aluminum

Pans	
ROY ALDP 48	48 oz
ROY ALDP 96	96 oz Pan
Covers	
ROY ALDP 48 C	Fits 48 oz Pan
ROY ALDP 96 C	Fits 96 oz Pan



## Dough Scrapers

- Stainless steel blade



ROY DGHS 6	6" x 3" Blade, Wood Handle
ROY DGHS 7	7" x 3½" Blade, Wood Handle
ROY DGHS P 6	6" x 3" Blade, Plastic Handle

## Pastry Bags

Canvas	Plastic Coated	
PST 10 C	PST 10 P	10"
PST 12 C	PST 12 P	12"
PST 14 C	PST 14 P	14"
PST 16 C	PST 16 P	16"
PST 18 C	PST 18 P	18"
PST 21 C	PST 21 P	21"
PST 24 C	PST 24 P	24"



## Rolling Pins

ROY RP 15	Wood, 15" Long
ROY RP 18	Wood, 18" Long
ROY RP 15 A	Aluminum, 15" Long



## Pizza Trays & Screens

Screen

Trays



### Wide Rim Trays

ROY PT 6	6"
ROY PT 8	8"
ROY PT 9	9"
ROY PT 10	10"
ROY PT 11	11"
ROY PT 12	12"
ROY PT 13	13"
ROY PT 14	14"
ROY PT 15	15"
ROY PT 16	16"
ROY PT 17	17"
ROY PT 18	18"

### Pizza Screens

ROY PS 8	8"
ROY PS 9	9"
ROY PS 10	10"
ROY PS 11	11"
ROY PS 12	12"
ROY PS 13	13"
ROY PS 14	14"
ROY PS 15	15"
ROY PS 16	16"
ROY PS 17	17"
ROY PS 18	18"

## Pizza Pans

Tapered Deep Dish



Straight Sided



### Straight Sided

ROY DP 10 1	10" x 1"
ROY DP 12 1	12" x 1"
ROY DP 14 1	14" x 1"
ROY DP 16 1	16" x 1"
ROY DP 6 2	6" x 2"
ROY DP 7 2	7" x 2"
ROY DP 8 2	8" x 2"
ROY DP 9 2	9" x 2"
ROY DP 10 2	10" x 2"
ROY DP 11 2	11" x 2"
ROY DP 12 2	12" x 2"
ROY DP 13 2	13" x 2"
ROY DP 14 2	14" x 2"
ROY DP 15 2	15" x 2"
ROY DP 16 2	16" x 2"

### Tapered Deep Dish

ROY TP 6	6" x 1½"
ROY TP 8	8" x 1½"
ROY TP 10	10" x 2"
ROY TP 11	11" x 2"
ROY TP 12	12" x 2"
ROY TP 13	13" x 2"
ROY TP 14	14" x 2"
ROY TP 15	15" x 2"
ROY TP 16	16" x 2"



Foodservice & Hospitality Products



### Tabletop Pizza Tray Stand

- Chrome plated heavy wire, 7" high
- Frees up valuable table space

ROY PTS 987	9" x 8"
ROY PTS 12127	12" x 12"

### Pizza Pan Gripper

ROY PG



### Pizza Screen Rack

- Chrome plated heavy gauge wire
- 4 compartments
- 14" x 6" x 10¼"

ROY PS 4

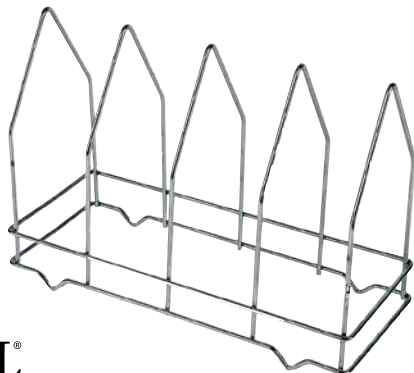

### Pizza Tray Stands

- Made of heavy chrome plated steel rod
- Each shelf can hold up to 6 pounds
- Stands measure 27½" high with 12" base
- For pans 10" to 17" in diameter

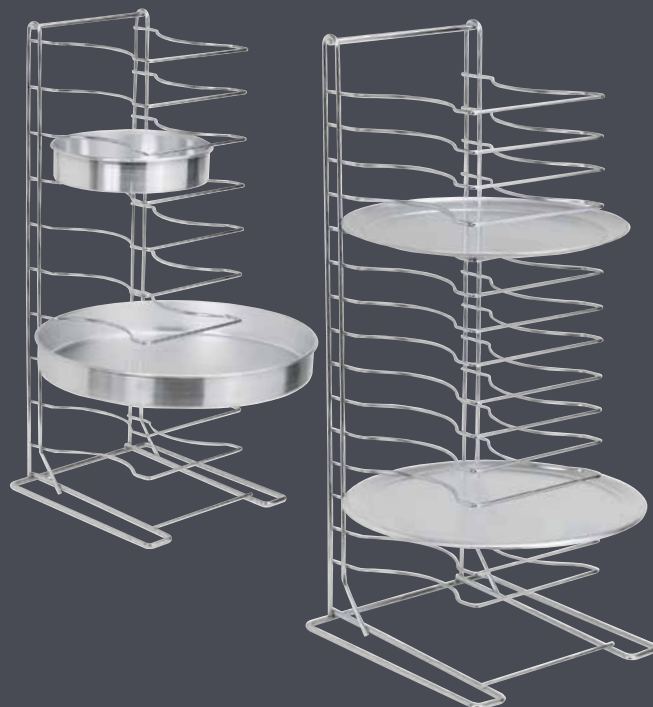

ROY PTS 11 HD	11 Shelves, 2¼" Spacing
ROY PTS 15 HD	15 Shelves, 1¾" Spacing



Foodservice & Hospitality Products

# KITCHEN





**Aluminum Pizza Peels**

ROY APP 121426	12" x 14" Blade, 12" Handle
ROY APP 121435	12" x 14" Blade, 21" Handle
ROY APP 121452	12" x 14" Blade, 38" Handle
ROY APP 6921	6½" x 9" Blade, 11" Handle

**Wide Blade Wood Pizza Peels**

- 6½" handle

ROY WPP 162936	16" x 29" Blade
ROY WPP 183642	18" x 36" Blade
ROY WPP 182936	18" x 29" Blade
ROY WPP 223642	22" x 36" Blade

**Wood Pizza Peels**

ROY WPP 121322	12" x 13" Blade, 22" Handle	ROY WPP 161718	16" x 17" Blade, 18" Handle
ROY WPP 121328	12" x 13" Blade, 28" Handle	ROY WPP 161724	16" x 17" Blade, 24" Handle
ROY WPP 141520	14" x 15" Blade, 20" Handle	ROY WPP 181824	18" x 18" Blade, 24" Handle
ROY WPP 141526	14" x 15" Blade, 26" Handle	ROY WPP 202121	20" x 21" Blade, 21" Handle



## Dough Dockers

- ROY DD 127 5" Wide Nylon Cylinder, Stainless Steel Pins
- ROY DD 34 Six Wheels, Plastic Points & Handle

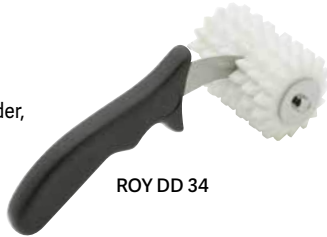

## Pie Servers

- ROY PS Wood Handle
- ROY PS P Plastic Handle

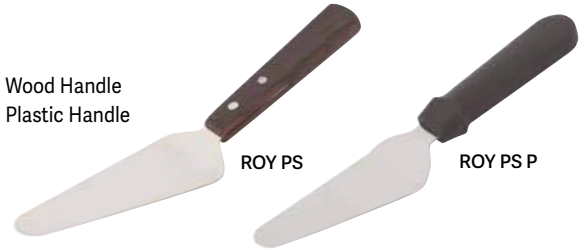

## Pizza Oven Brush

- Brass bristles and metal scraper
- ROY BR PZA 36" Wood Handle

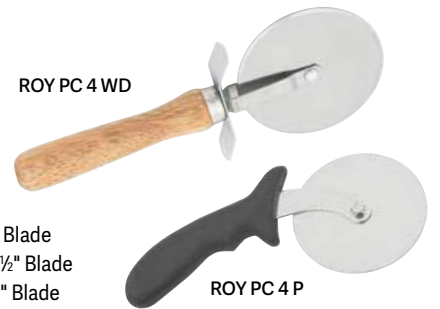

## Pizza Cutters

- ROY PC 4 WD Wood Handle, 4" Blade
- ROY PC 2 P Plastic Handle, 2½" Blade
- ROY PC 4 P Plastic Handle, 4" Blade

## Insulated Pizza Delivery Bags

- Each bag holds 2 pizza boxes



- ROY PZA BAG 18 18" x 18", For 16" Pizza Box
- ROY PZA BAG 20 20" x 20", For 18" Pizza Box
- ROY PZA BAG 24 24" x 24", For 23" Pizza Box



## Dredges

- ROY DRG S 7 Stainless Steel, 7" Tall, without Handle
- ROY DRG SH Stainless Steel, 10 oz, with Handle
- ROY DRG S Stainless Steel, 10 oz, without Handle
- ROY DRG AH Aluminum, 10 oz, with Handle
- ROY DRG A Aluminum, 10 oz, without Handle





## Pizza Peels

- Sanitary solution for pizza and sandwich preparation
- Pizza peels double as excellent cutting boards and the beveled edges allow for smooth pickup of cooked or toasted foods
- Cleanup is a breeze—simply place into the dishwasher to be sanitized
- Thin profile and handle hole makes these boards easy to stack and store

407-261601	Rectangular w/Handle, 16"w x 26"l x ¼"h, Natural Finish
407-261602	Rectangular w/Handle, 16"w x 26"l x ¼"h, Slate Finish
429-211601	Round w/5" Handle, 16" dia x ¼"h, Natural Finish
429-211602	Round w/5" Handle, 16" dia x ¼"h, Slate Finish
429-001601	Round No Handle, 16" dia x ¼"h, Natural Finish
429-001602	Round No Handle, 16" dia x ¼"h, Slate Finish

**epicurean**  
By Victorinox



Other sizes available, please contact your local sales representative for details.

## Dredge/Measuring Cup

- Acrylic with Handle
- Graduated measurements in milliliters and ounces
- Includes 3 interchangeable plastic lids with fine, medium, and large perforations



ROY DRG PH 3 8 oz



**ROYAL INDUSTRIES**  
Foodservice & Hospitality Products

## Cheese Shakers

- Stainless steel lids
- Dishwasher safe

### Glass Jars

ROY CS 6 P	6 oz, Perforated Top
ROY CS 6 S	6 oz, Slotted Top
ROY CS 12 G	12 oz Paneled, Perforated Top

### Plastic Jars

ROY CS P 6 P	6 oz, Perforated Top
ROY CS P 6 S	6 oz, Slotted Top
ROY CS 12	12 oz Paneled, Perforated Top

### Replacement Lid

ROY CS 12 L	Stainless Steel, Perforated, 1 dz
-------------	-----------------------------------

**winco**  
Pizza Dough Boxes & Cover

- Great for storing and proofing dough
- Boxes stack tight to maintain freshness of content
- Reinforced structure resists breakage/bending over time
- Made of durable polypropylene
- BPA-free

PL-3N	Dough Box, 18"w x 25½"l x 3¼"h
PL-6N	Dough Box, 17½"w x 25½"l x 6"h
PL-36NC	Dough Box Cover

## Pizza Dough Boxes & Cover

- Great for storing and proofing dough
- Stackable space-saving design
- Polypropylene material



PLDB182606PP

**THUNDER GROUP INC.**  
SINCE 1996

PLDB182603PP	Dough Box, 18"w x 26"l x 3"h
PLDB182606PP	Dough Box, 18"w x 26"l x 6"h
PLDBC1826PP	Dough Box Cover, 18"w x 26"l

## Wire Dough Box Dolly

- Transport multiple dough boxes with ease
- Up to 400 lb capacity
- 3¾" dia wheels

DWR-2617  
18¼"w x 27"l x 2½"h

**winco**



# KITCHEN

## Saf-T-Ice® Totes

- Allows you to transport ice safely, helping you avoid potential ice contamination
- Durable and dishwasher safe
- Unable to nest; prevents stacking
- Tougher Handi-Hook™ hangs tote upside down on wire shelving or hanging bracket
- HACCP Hanger™ makes filling totes faster, safer and easier



SI6000 Original Ice Tote, 6 gal, Clear Blue  
SI6100 Shorty™ Ice Tote, 5 gal, Clear Blue

- The SI6000 is ideal for high capacity carrying and manual cleaning
- The SI6100 is shorter in size for lighter carrying and easier cleaning in dishwasher



## Saf-T-Scoop® & Guardian™ System

- Includes 1 Saf-T-Scoop®, 1 Guardian™ Holder with removable drainage cap & mounting accessories
- Each Saf-T-Scoop® features two Germ Guards™ to protect ice from contact with hands
- Guardian™ System has removable drain cap to allow bottom to be sealed or open and features a built-in hook to store scoop on side of ice bin
- Commercial dishwasher safe

For Bar & Beverage Stations

SI5000 6-10 oz  
SI7000 12-16 oz  
SI7700 20-24 oz

For Ice Machines

SI9000 64-86 oz



## Banquet/Beverage Saf-T-Scoop®

- Germ-Guards™ protect ice from contact with hands
- Drain holes prevent watering down of beverages
- Built-in hook prevents cross contamination; stores neatly on side of bin



SI4550 Saf-T-Scoop® Only,  
4 to 6 oz

## Rapi-Kool® Plus

- Helps to rapidly chill food through the temperature danger zone, 135° to 70°F in 2 hours, then to 41°F within 4 hours
- Chills product from the "inside out" for faster, even cooling

- Large opening allows you to fill with ice and water – no need to freeze
- Durable polycarbonate construction; dishwasher safe
- Fill-Rite™ design eliminates looking for fill line



RCU64V2 64 oz  
RCU128V2 128 oz



## AquaChek™ 5 Water Test Strips

- Tests five water conditions in one minute
- Each "Dip & Read" strip tests free chlorine (0-10 PPM), total chlorine (0-10 PPM), total hardness (0-425 PPM or 0-25 grains per gallon), total alkalinity (0-240 PPM as CaCO3) and pH (6.4-8.8)



85-1255 50 Strips per Bottle

## SofChek™ Water Hardness Test Strips

- Measures total hardness (0-425 PPM or 0-25 grains per gallon) in just 15 seconds

85-1259 50 Strips per Bottle



## Test Paper Strips

- Packaged with color-coded test charts
- 100 strips per package



85-1244

85-1242 For Chlorine Sanitizers  
85-1244 For Quaternary Ammonia Compounds





### Pen Style Pocket Digital Thermometer

- High accuracy  $\pm 1^\circ\text{F}$ ,  $0.5^\circ\text{C}$
- Waterproof
- Thin tip probe for fast response in under 6 seconds
- MAX temperature hold for commercial dishwashers
- Field calibratable
- Auto power off conserves battery life
- Maximum temperature hold
- Slim profile fits flat in pocket
- Data hold to freeze a reading
- Five year limited warranty
- BioCote® antimicrobial reduces the risk of cross-contamination

PDQ400 -4° to 400°F/-20° to 200°C 

### Bluetooth Pocket Thermometer

- Transmits temperature data via Bluetooth to your Android or iOS phone or tablet
- Waterproof with fold-out probe
- Probe can be angled for ergonomic use
- Resolution:  $0.1^\circ$
- Accuracy  $\pm 2^\circ\text{F}$
- Auto switch off to preserve battery life
- Battery Life of up to 1000 hours
- BioCote® antimicrobial



BT250KC -58° to 482°F

Use with the Comark Kitchen Checks App to manage all your HACCP temperature recordings.

### Digital Pocket Thermometer

- Thin 1.5 mm tip for fast response
- Waterproof
- Max temperature hold for commercial dishwashers
- Field calibratable
- High accuracy,  $\pm 1^\circ\text{F}$ ,  $0.5^\circ\text{C}$
- 1 year warranty



DT400 -4° to 400°F/-20° to 200°C 

### Digital Pocket Thermometer

- Waterproof
- Field calibratable
- Fits flat in pocket
- Unique Biocote® protection
- °F/C switchable
- Data hold function to freeze a reading
- Uses 1.5V battery
- Accuracy  $\pm 2^\circ\text{F}$

PDT300 -58° to 300°F/-50° to 150°C





### Waterproof Type K Thermocouple

- Case with built-in protective rubber boot
- Includes a permanent clock and countdown timer within the display
- Probe has BioCote Antimicrobial Protection
- Includes PK19M Thin Tip Penetration Probe

C48KIT -328°F to 2502°F/-200°C to 1372°C



 **COMARK**  
A Fluke Company





### Type K Thermocouple

- Water resistant with easily cleanable membrane keypad
- Accuracy  $\pm 2^\circ\text{F}$
- With PK19M reduced tip penetration probe and CRS/5 protective boot

KM28KIT -40° to 1000°F/-40° to 500°C

### Pocket Digital Thermometer

- Quick response time with 1.5mm thin tip probe
- $\pm 2^\circ\text{F}$  accuracy
- Water resistant
- Rugged design withstands a 10 ft drop with the protective boot
- Protective probe sheath with BioCote® antimicrobial protection
- 1 year warranty



400YB -58° to 400°F/-50° to 200°C 

### Refrigerator/Freezer Thermometer

- Hangs in or sticks inside
- Switchable °F/°C scale
- Low battery indication
- Accuracy  $\pm 2^\circ\text{F}$  or  $1^\circ\text{C}$

DRF1 -22° to 158°F/-30° to 70°C





### Infrared Thermometers

- Infrared thermometers quickly scan food surface to signal "safe" or "unsafe" HACCP temperatures
- FPP has a built-in temperature probe for critical internal measurements
- 7 second display hold with auto switch off
- Two year warranty

FP FoodPro Thermometer, Temp. Range: -22° to 400°F/-30° to 205°C  
 FPP FoodPro Plus Thermometer w/Integral Penetration Probe, Temp. Range – Infrared: -30° to 525°F/-35° to 275°C; Probe: -40° to 392°F/-40° to 200°C





KITCHEN

# KITCHEN

## Compact Waterproof Digital Thermometer

- 1.5 mm FDA recommended step down probe
- Accuracy  $\pm 2^{\circ}\text{F}$
- Safe-T-Guard™ Antimicrobial case and sleeve
- Uses one CR2032 battery (included)



9877FDA -4° to 450°F/-40° to 232°C

## Digital Refrigerator/Freezer Thermometer

- Compact size with bold LCD readout
- Hangs or stands
- Battery included

1443 -4° to 140°F/-20° to 60°C



## Compact Digital Thermometer

- 1.5 mm FDA recommended fold-out probe
- Large easy-to-read 0.7" LCD
- On/off switch and auto off to conserve battery life
- Lanyard and magnetic back mounts

1476FDA -40° to 250°F/-40° to 121°C



**TAYLOR**

## Cold-Zone Infrared Thermometer

- Scan, lock, min/max temp & auto off features
- 1 second response time
- Includes protective rubber casing
- Operates on lithium battery, included

9527 -67° to 428°F/-55° to 220°C



## Color Coded Food Safety Thermometer Set

**TAYLOR**

- 1" dial with 5" stem
- Pocket sleeve with patented built-in calibration feature
- Set contains one thermometer for each food product category: Yellow - Poultry, Red - Raw Meat, Purple - Allergen, Blue - Seafood, Brown - Cooked Meat

6092N-FSA 0° to 220°F/-10° to 100°C

## Digital PH & Water Temperature Meter

- PH Range: 0.00-14.00
- Temperature Compensation from 32° to 122°F
- 3 point calibration: 4.01, 6.8, 9.18
- Calibration powder buffer solution - 1 for each calibration point included
- (4) LR44 batteries, included
- Durable hard plastic storage case, included
- Automatic shut off
- 1 year warranty

6580 Meter  
6580RP Replacement Probe Tip with Protective Cap



## TempRite Refrigerator/Freezer Thermometer

- Propylene glycol filled thermometer simulates food temperature for more accurate and stable readings
- Bright blue, red and green graphics with safe temp. zone indicators
- Stands or hangs

5927 -20° to 60°F/-30° to 30°C





**TAYLOR**

### Thermocouple Thermometer With K-Type Probe

- Compact size
- Oversized 1.1" readout
- Hold function
- C/F switch
- Includes 3.9" K-Type Step-Down Probe with 5 second response time
- Uses 2 AAA batteries (included)

9821PBN -58°F to 662°F/-50° to 350°C

### Probe Wipes

- Cleans and sanitizes food thermometers and meat probes
- Saturated with 70% isopropyl alcohol

9999N Box of 100 Individual Packets  
9999T Tub of 70 Wipes



KITCHEN

### Continuous Ring Digital Timer

- Super loud 95 decibel ring
- Alarm will not turn off until a button is pushed
- Beautiful stainless steel overlay for a high-end look
- Non-skid base
- 12/24 hour clock function
- Uses 2 AAA batteries (included)



5873

**TAYLOR**

### Four Event Digital Timer

- Times 4 events simultaneously
- 1 1/4" LCD display
- New volume adjustment control
- Stands or wall mountable
- Uses 4 AA batteries (included)

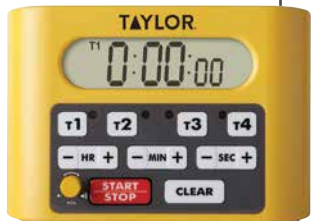

5839N Counts to 9 Hours, 59 Minutes and 59 Seconds

### Digital Timer

- Chrome accents
- 0.8" LCD readout
- 12/24 hour clock feature



584721 Times up to 23 Hours, 59 Minutes & 59 Seconds

### HACCP Wall Thermometers

- Clear, break-resistant lens
- HACCP referenced color-zoned dial
- Cooler/Freezer thermometer: 0° to 80°F, Dry Storage thermometers: 0° to 100°F
- Increments of 2°F
- 13 1/4" dia, white frame

5680 Cooler/Freezer  
5681 Dry Storage



5681

### Non-Contact Mini Infrared Thermometer

- Compact and easy to scan
- Infrared range: -27°F to 390°F
- Operating range: 32°F to 122°F
- Spot to Distance 1:1
- Emissivity Range: 0.95 fixed Auto
- Shut-off extends battery life
- Resolution: 0.5°F
- Battery: 1 CR2032 (included)
- 1 year limited warranty

9526



### Folding Thermocouple Thermometer

- 1.5 mm step-down probe
- Waterproof IP67 rated
- NIST certified



9868FDA -40° to 572°F/-40° to 300°C

# KITCHEN



## Escali Gourmet Thermometer

- Stainless steel sheath and pocket clip with target cooking temperatures
- Blue
- 4 1/8" probe

THDGBL -49° to 392°F/-45° to 200°C



## Folding Digital Thermometer

- Folding stainless steel probe
- Target cooking temperatures on handle
- 4.6" probe

THDGFLD -49° to 392°F/-45° to 200°C



## Escali Pro MZR™ Waterproof Digital Thermometer

- 3" stainless steel thin tip probe
- Heat treated ABS plastic protective sheath
- Hold function
- Dishwasher safe
- Blue

THDGWP -58° to 482°F/-50° to 250°C



## Digital Timer

- Count-Up and Count-Down functions
- Easel stand and magnetic back clip
- Timing capacity of 99:59 with memory function



ULT264



151-8800

## Programmable Digital Timers

- Water-resistant keypad and housing
- Countdown timers w/memory recall feature
- Hour, minute and second adjustable
- Large LCD display
- Color-coded time cycle lights
- High/Low volume control
- Requires 9V battery (included) or optional AC adaptor (not included)



- Non-skid feet
- Can be wall mounted
- Antimicrobial housing
- 1 year warranty

151-7500 4-In-1™ Timer

151-8800 8-In-1™ Timer

4-In-1™ Timer

- 4 countdown timers

10-hour countdown

8-In-1™ Timer

- 8 countdown timers

20-hour countdown or count-up feature

## Extra Large Display Digital Timer

- Count up and down
- Flashing LED and loud alarm
- Timer and stopwatch functions
- Dual display options
- Magnetic stand
- Batteries included



TMDGXL 99 Minutes; 59 Seconds



## Touch Screen Digital Timer

- Features touch screen power-saving display and memory recall
- Counts up or down
- Magnetic back
- 1 year warranty



TMDGTS 99 Minutes, 59 Seconds

## Portion Control Scales

- Stainless steel construction
- Easy-to-read, angled dial designs with bold graphics
- Protective shatterproof lenses
- Spacious, removable platforms
- Simple-to-use tare system

TS25KL



# TAYLOR

	Capacity	Dial Type
TS32	32 oz x ¼ oz	Rotating
TS32D	32 oz x ¼ oz, w/Dashpot	Rotating
TS32F	32 oz x ¼ oz	Fixed
TS5	5 lb x ½ oz	Rotating
TS25KL	25 lb x 2 oz/11 kg x 50 g	Rotating
TS50	50 lb x 4 oz	Rotating

## Compact Mechanical Portion Control Scales

- Antimicrobial housing
- Corrosion resistant stainless steel construction
- Easy-to-read, angled dial with bold graphics
- Internal stop mechanisms

TP16	16 oz x ¼ oz
TP32 (Ice Cream)	32 oz x ¼ oz



TP16

# TAYLOR

## Heavy-Duty Mechanical Scales

- 9" x 9" stainless steel platform
- Easy to read angled dial
- Dual measurement oz and grams
- Internal stop mechanisms

THD32	32 oz x ⅛ oz
THD32D	32 oz x ⅛ oz, w/Dashpot
THD50	50 lb x 2 oz



THD50

## Digital Portion Control Scale with Tower Readout

- 6.7" x 6.7" stainless steel platform
- Weighs in pounds, ounces and kilograms
- Dry and liquid measurement
- 1½" LCD readout with backlight
- Tare, hold, calibration and auto off features (auto off cannot be disabled)
- Low battery and overload indicators
- Operates on AC adapter (included) or 6 AAA batteries (not included)

TE10T	10 lb x 0.002/160 oz x 0.05 oz/5000g x 0.001 kg/ 169 fl oz x 0.05 fl oz/5000 ml x 1 ml
-------	---



## Compact Digital Portion Control Scale

- 5.4" x 5.4" stainless steel platform with marine edge
- Extra large 0.9" readout
- Tare and hold function
- Auto-off and disable auto-off feature when powered by batteries
- Operates on 2 AAA batteries (not included) or AC adaptor (included)

TE32FT	2 lb x 0.01 oz/ 1 kg x 0.5 g
--------	---------------------------------



# TAYLOR

## Digital Portion Control Scale

- 3.5" x 11.5" S/S platform
- Tare and hold and counting functions
- Auto-off and disable auto-off features
- Field calibration
- Operates on AC adapter (included) or 4 AA batteries (not included)

TE50	50 lb x 0.5 oz/ 22 kg x 0.1 kg
------	-----------------------------------



KITCHEN

# KITCHEN

## Digital Portion Control Scales

- Removable stainless steel platform with marine edge
- 0.9" readout
- Tare and hold functions
- Auto off and disable auto off feature when powered by batteries
- Operates on AC adapter (included) or 2 AAA batteries (not included)



TE11FT



### 7.2" x 7.2" Platform

- TE11FT 11 lb x 0.1 oz/5 kg x 1 g
- TE22FT 22 lb x 0.1 oz/10 kg x 1 g

### Compact, 5.4" x 5.4" Platform

- TE10FT 11 lb x 0.1 oz/5 kg x 1 g

## Compact Digital Portion Control Kitchen Scale

- 7.15" x 7.15" stainless steel platform
- Extra large 0.9" LCD readout
- Tare and hold function
- Calibration feature
- Auto-off and disable auto-off feature when powered by batteries
- Operates on AC adapter (included) or 2 AAA batteries (not included)



TE2FT 2 lb x 0.1 oz



## Waterproof Digital Portion Control Scale

- IP67 waterproof rating sealed components
- 4.75" x 5.9" removable stainless steel platform
- Auto off and disable auto off feature when powered by battery
- 0.8" LCD digits in a 0.9" readout
- Tare function
- Calibration feature for in-field adjustment
- Low battery and overload indicators



- Operates on AC adapter (included) or (1) 9-volt battery (not included)

TE10CSW 10 lb x 0.002 lb/10 lb x 0.05 oz/160 oz x 0.05 oz/5000 g x 1 g/160 fl oz x 0.05 fl oz/5000 ml x 1 ml

## Digital Portion Control Scale

- 5.25" x 5.25" removable stainless steel platform with marine edge, tare & hold function, auto-off & disable auto-off feature (powered by batteries)
- ABS plastic base
- 1.0" LCD display
- Low battery & overload indicators



TE11FTP 11 lb x .1 oz



## Waterproof Digital Portion Control Scale

- Waterproof housing with stainless steel platform and base
- IP67 waterproof rated
- Dry and liquid measurement
- Easy-to-read 0.5" LCD digits
- Corrosion-resistant 6½" x 7" platform
- Easy-to-clean, sanitary contact surface
- Tare, auto off, and low battery indicator features
- Dual powered by either a 110V adaptor or rechargeable battery (both included)
- Moisture-resistant sealed components



TE10SSW 10 lb x 0.005 lb/10 lb x 0.1 oz/10 lb x ⅛ oz 160 oz x 0.05 oz/160 oz x ⅛ oz/5000 g x 1 g



## Digital Portion Control Scale w/Oversized Platform

- Large 14" x 10" removable stainless steel platform
- 0.7" LCD digits in a 0.9" readout
- Tare and hold functions
- Auto off and disable auto off feature when powered by batteries
- Low battery and overload indicators
- Operates on AC adapter (included) or 2 AAA batteries (not included)

### Capacity

TE22OS 22 lb x 0.1 oz/10 kg x 1 g



## Heavy-Duty Mechanical Receiving Scale

- Press down "lock and hold" feature
- Built-in carrying handle
- Easy-to-read dial
- Shatterproof lens
- 13" x 11" ribbed platform



TR250 250 lb x 1 lb





### M-Series Scale

- Display hold
- Tare feature
- Sealed display
- Automatic shutoff
- 9V batteries included



SCDGM66  
66 lb x 0.1 oz



### Mechanical Dial Scale

- Stainless steel construction
- Shatterproof dial cover
- Removable access panel for internal cleaning
- Tare function with rotating dial
- Water resistant

SCMDL5  
5 lb x 1/2 oz



### Escali Professional Digital Scale

- 5 1/2" stainless steel removable platform
- Measures in grams, pounds + ounces & ounces
- Tare feature
- Two-button operation with auto shut-off
- 2 AA batteries included
- Metallic finish
- 6" w x 8 1/2" d x 1 3/8" h

SCDGP11M 11 lb x 0.1 oz



### Digital Receiving Scale

- Easy-to-read 1" LCD control panel with 6 ft cord and mounting bracket
- Painted, removable steel tread plate platform
- Low 2" profile design
- Non-skid feet
- Tare, hold, auto off and low battery indicator features
- Dual-powered by either 120V adaptor (included) or 6 AA batteries (not included)

TE400 400 lb x 0.5 lb/180 kg x 0.2 g



### Digital Receiving Scale

- 11" x 11 1/2" stainless steel platform
- Auto-off and disable auto-off
- AC adaptor included

TE220FT 220 lb x 2 oz

### Slimline Digital Scale

- Low profile design
- Touch screen display
- Extra large weighing surface
- Water resistant front panel
- 12.6" w x 10.1" d x 1" h
- 4 AA batteries (included)

SCDGL33 33 lb x 0.05 oz



### Heavy-Duty Receiving Scale

- Digital display in ounces or pounds; accurate within 1/10 lb
- 12" x 15" stainless steel platform
- Tare feature
- Can withstand environments from 14" to 122" F
- Includes: Printer cable for use with printer; cross reference weight to gallons chart; 120V AC adaptor and four AAA batteries
- Wall bracket for display

280-1564  
400 lb Capacity



# KITCHEN

## Table-Mount Can Opener

- 14" shaft, fully adjustable
- Opens all cans including #10 cans
- Nickel plated cast iron

COTM-1



## Swing-A-Way® Manual Can Openers

- Stainless steel construction with rubber handles
- Swing grips provide comfort, style, and performance

709BK



6090



- 709BK Comfort Grip, Black Handle
- 6080 Extra Easy Pivoting Crank, Black Swing Grips
- 6090 Easy Crank, Black Swing Grips
- 407 2 Each Compact Openers, Black, Red, White Handles



CO-1

## Standard #1 Manual Can Opener

- Opens #10 and smaller can sizes
- Rust-resistant steel body
- Includes base, blade, gear, and installation kit

CO-1 Cast Iron Body



CO-3



## Premium Manual Can Opener

- S/S blade and gear opens #10 can sizes and smaller
- Includes base, blade, gear and installation kit
- Portable clamp included

CO-3 Heavy-Duty Nickel-Plated Body

## Twist & Out™ Can Openers

- Chrome-plated
- Soft-grip handle helps to reduce hand fatigue
- Smooth cutting blade makes all day prep easier
- Durable frame handles size 10 cans



CO-901

CO-902

- CO-901 7"l, Easy-Turn Handle
- CO-902 8¾"l, Crank Handle



## FreshWorks™ Produce Saver Sets

- Keeps produce fresher longer
- Reduces spoilage
- Clear polycarbonate
- Includes lid, filter and drain tray
- Made in USA

Ready to learn more about these great products?

**PLAY VIDEO**



	W x D x L	Capacity
2052879	12" x 6½" x 18"	3 gal
2052933	12" x 9½" x 18"	5 gal
2052931	18" x 6½" x 26"	8 gal
2052878	18" x 9½" x 26"	12 gal





## Camwear® Polycarbonate Food Pans & Lids

- Virtually unbreakable polycarbonate construction
- Withstands temperatures from -40° to 210°F
- Has both standard and metric graduation markings
- Three-in-one service: storage, transportation and serving display
- Non-stick smooth interior surface increases yields and promotes easy cleaning
- Stacks neatly, without wedging or sticking
- Colors: Clear (135), Black (110)



### Full Size - 20<sup>7</sup>/<sub>8</sub>" x 12<sup>3</sup>/<sub>4</sub>"

- 12CW 2<sup>1</sup>/<sub>2</sub>" deep
- 14CW 4" deep
- 16CW 6" deep
- 18CW 8" deep
- 13CLRCW Colander Pan, Fits 4" d+
- 15CLRCW Colander Pan, Fits 6" d+
- 10CWC Flat Lid
- 10CWCH Handled Lid
- 10CWCHN Notched Lid w/Handle
- 10CWD Drain Shelf

### Half Size Long - 20<sup>7</sup>/<sub>8</sub>" x 6<sup>3</sup>/<sub>8</sub>"

- 22LPCW 2<sup>1</sup>/<sub>2</sub>" deep
- 24LPCW 4" deep
- 20LPCWC Flat Lid
- Half Size - 12<sup>3</sup>/<sub>4</sub>" x 10<sup>7</sup>/<sub>16</sub>"
- 22CW 2<sup>1</sup>/<sub>2</sub>" deep
- 24CW 4" deep
- 26CW 6" deep
- 28CW 8" deep
- 23CLRCW Colander Pan, Fits 4" d+
- 25CLRCW Colander Pan, Fits 6" d+
- 20CWC Flat Lid
- 20CWCH Handled Lid
- 20CWCHN Notched Lid w/Handle
- 20CWL FlipLid®, Solid
- 20CWLN FlipLid®, Notched
- 20CWD Drain Shelf

### Third Size - 12<sup>3</sup>/<sub>4</sub>" x 6<sup>15</sup>/<sub>16</sub>"

- 32CW 2<sup>1</sup>/<sub>2</sub>" deep
- 34CW 4" deep
- 36CW 6" deep
- 38CW 8" deep
- 33CLRCW Colander Pan, Fits 4" d+
- 35CLRCW Colander Pan, Fits 6" d+
- 30CWC Flat Lid
- 30CWCH Handled Lid
- 30CWCHN Notched Lid w/Handle
- 30CWL FlipLid®, Solid
- 30CWLN FlipLid®, Notched
- 30CWD Drain Shelf
- Quarter Size - 10<sup>7</sup>/<sub>16</sub>" x 6<sup>3</sup>/<sub>8</sub>"
- 42CW 2<sup>1</sup>/<sub>2</sub>" deep
- 44CW 4" deep
- 46CW 6" deep
- 40CWC Flat Lid
- 40CWCH Handled Lid
- 40CWCHN Notched Lid w/Handle
- 40CWD Drain Shelf

### Sixth Size - 6<sup>15</sup>/<sub>16</sub>" x 6<sup>3</sup>/<sub>8</sub>"

- 62CW 2<sup>1</sup>/<sub>2</sub>" deep
- 64CW 4" deep
- 66CW 6" deep
- 63CLRCW Colander Pan, Fits 4" d+
- 65CLRCW Colander Pan, Fits 6" d+
- 60CWC Flat Lid
- 60CWCH Handled Lid
- 60CWCHN Notched Lid w/Handle
- 60CWL FlipLid®, Solid
- 60CWLN FlipLid®, Notched
- 60CWD Drain Shelf
- Ninth Size - 6<sup>15</sup>/<sub>16</sub>" x 4<sup>1</sup>/<sub>4</sub>"
- 92CW 2<sup>1</sup>/<sub>2</sub>" deep
- 94CW 4" deep
- 90CWC Flat Lid



### Colander Pans

- Polycarbonate
- Withstands temps. from -40° to 210°F
- Improve food safety through reduced product handling
- Clear (135)



### FlipLids®

- Polycarbonate
- Withstands temps. from -40° to 210°F
- Lid opening flips up to easily access contents without removing lid from pan
- Clear (135)

# KITCHEN

## Camwear® Round Food Storage Containers & Seal Covers

- Crystal clear Camwear® virtually unbreakable polycarbonate
- Withstands temperature ranges from -40° to 210°F
- Red graduation marks
- Stain-resistant
- Translucent seal covers provide excellent spill resistance and withstand temperatures from -40°F to 160°F
- Container color: Clear (135)
- Seal cover color: Translucent (190)

RFSCW1	1 qt	<b>Seal Covers</b>	
RFSCW2	2 qt	RFS1SCPP	Fits 1 qt
RFSCW4	4 qt	RFS2SCPP	Fits 2 & 4 qt
RFSCW6	6 qt	RFS6SCPP	Fits 6 & 8 qt
RFSCW8	8 qt	RFS12SCPP	Fits 12, 18 & 22 qt
RFSCW12	12 qt		
RFSCW18	18 qt		
RFSCW22	22 qt		



## Translucent Food Pans & Lids

- An economical food pan choice for prep tables, food bars and vending carts
- Translucent polypropylene material allows for content visibility
- Withstands temperature ranges from -40° to 160°F
- Precisely designed to Gastronorm GN specification
- Uniform 1/2" flange width ensures the right fit in prep tables and food bars
- Ideal for transporting in top loading Cambro food pan carriers
- Non-stick smooth interior surface increases yield and eases cleaning
- Color: Translucent (190)



<b>Full Size - 20<sup>7</sup>/<sub>8</sub>" x 12<sup>3</sup>/<sub>4</sub>"</b>		<b>Third Size - 12<sup>3</sup>/<sub>4</sub>" x 6<sup>5</sup>/<sub>16</sub>"</b>		<b>Sixth Size - 6<sup>15</sup>/<sub>16</sub>" x 6<sup>3</sup>/<sub>8</sub>"</b>	
14PP	4" deep	34PP	4" deep	64PP	4" deep
16PP	6" deep	36PP	6" deep	66PP	6" deep
10PPCH	Handled Lid	30PPCH	Handled Lid	60PPCH	Handled Lid
10PPCWSC	Seal Cover	30PPCHN	Notched Handled Lid	60PPCHN	Notched Handled Lid
<b>Half Size - 12<sup>3</sup>/<sub>4</sub>" x 10<sup>7</sup>/<sub>16</sub>"</b>		30PPCWSC	Seal Cover	60PPCWSC	Seal Cover
24PP	4" deep	<b>Quarter Size - 10<sup>7</sup>/<sub>16</sub>" x 6<sup>3</sup>/<sub>8</sub>"</b>		<b>Ninth Size - 6<sup>15</sup>/<sub>16</sub>" x 4<sup>1</sup>/<sub>4</sub>"</b>	
26PP	6" deep	44PP	4" deep	94PP	4" deep
20PPCH	Handled Lid	46PP	6" deep	90PPC	Handled Lid
20PPCWSC	Seal Cover	40PPCH	Handled Lid	90PPCWSC	Seal Cover
		40PPCWSC	Seal Cover		



## Camwear® CamSquare® Food Storage Containers & Lids

- Super tough Camwear® polycarbonate
- Withstands temperature ranges from -40° to 210°F
- Translucent seal covers provide excellent spill resistance and withstand temperatures from -40° to 160°F
- Red graduation marks
- Stain and odor resistant
- Container color: Clear (135)
- Seal cover color: Translucent (190)



2SFSCW	2 qt	<b>Lids</b>	
4SFSCW	4 qt	SFC2	Fits 2 & 4 qt
6SFSCW	6 qt	SFC6	Fits 6 & 8 qt
8SFSCW	8 qt	SFC12	Fits 12, 18 & 22 qt
12SFSCW	12 qt	<b>Seal Covers</b>	
18SFSCW	18 qt	SFC2SCPP	Fits 2 & 4 qt
22SFSCW	22 qt	SFC6SCPP	Fits 6 & 8 qt
		SFC12SCPP	Fits 12, 18 & 22 qt



## StoreSafe® Food Rotation Labels

- Eliminates scraping and saves operators time and money
- Both adhesive and label dissolve completely in less than 30 seconds off any storage container when washed through the dishwasher or under running water
- They are easy and safe to use for labeling all stored food products in the cooler, freezer, dry storage or in food pan carriers



1252SLB250



23SL



23SLB250

1252SLB250	1 1/4" x 2", Roll of 250, Bulk Dispenser Pack, Printed
23SL	2" x 3", Roll of 100, Blister Pack
23SLB250	2" x 3", Roll of 250, Bulk Pack
23SLB6250	2" x 3", Roll of 250, Bulk Dispenser Pack

← Leaves no sticky residue



KITCHEN



## Camwear® Food Storage Boxes & Lids

- Super tough  
Camwear® polycarbonate
- Withstands temperature ranges from -40° to 210°F
- Stack securely loaded or unloaded, fit standard carts and racks and are dishwasher safe
- Smooth surfaces for easy cleaning
- Color: Clear



<b>12" x 18"</b>		<b>18" x 26"</b>	
12183CW	3 1/2" deep, 1.75 Gallon	18263CW	3 1/2" deep, 5 Gallon
12186CW	6" deep, 3 Gallon	18266CW	6" deep, 8.75 Gallon
12189CW	9" deep, 4.75 Gallon	18269CW	9" deep, 13 Gallon
1218CCW	Lid	182612CW	12" deep, 17 Gallon
1218SCCW	Sliding Lid	182615CW	15" deep, 22 Gallon
		1826CCW	Lid
		1826SCCW	Sliding Lid



**Colander Kit, 18" x 26"**  
18268CLRKIT Includes an 8" d Colander, 9" d Food Box, and Sliding Lid

# KITCHEN

**san jamar**  
smart. safe. sanitary.



## Saf-T-Wrap® Stations

- Prevents contamination of film, foil or paper rolls
- Combined tools for speed – includes date label dispenser
- Side caddies hold pens, cutters or other tools
- Safe and efficient replaceable safety cutting blade
- Holds date label rolls ¾" to 3" wide x 3¼" dia
- Holds film, foil or paper roll 12" to 18" wide x 5.1" total dia
- 4 suction cups hold securely to table top or hangs on wire shelf or wall
- Dishwasher safe



SW1218 With Safety Blade  
SW1218SC With Slide Cutter



## Countertop Film Wrapper



- Aluminum and stainless steel construction
- Teflon covered hot plate
- 22¼" w x 24" l x 5" h

WHSS-1



## Datelt™ Trilingual Removable Labels

- Reduce waste and spoiled food using a food rotation system
- Save valuable time and money
- 1" x 1"
- 1000 labels per roll

R101R Monday, Blue  
R102R Tuesday, Yellow  
R103R Wednesday, Red  
R104R Thursday, Brown  
R105R Friday, Green  
R106R Saturday, Orange  
R107R Sunday, Black

## LabelLocker™ Label Dispenser Kit

- Easy to refill with individual replacement rolls (sold separately)
- Hard plastic shell protects the labels
- Hangs on the wall, shelves or peg board

R1KIT For 1" x 1" Trilingual Labels

Jackson & Associates Presents...



Jackson & Associates Presents...





**THUNDER GROUP INC.**



### Square Food Storage Containers & Lids

- Translucent polypropylene is stain and chemical resistant
- BPA-free
- Withstands temperatures from -40° to 160°F
- Colored graduation markings in liters and quarts
- Stackable design

#### Containers

PLSFT002TL	2 qt
PLSFT004TL	4 qt
PLSFT006TL	6 qt
PLSFT008TL	8 qt
PLSFT012TL	12 qt
PLSFT018TL	18 qt
PLSFT022TL	22 qt

#### Lids

PLSFT0204C	Fits 2 & 4 qt, Green
PLSFT0608C	Fits 6 & 8 qt, Red
PLSFT121822C	Fits 12, 18 & 22 qt, Blue



**KITCHEN**

### Round Food Storage Containers & Lids

#### Clear Polycarbonate

- Durable—shatter and scratch resistant
- Withstands temperatures from -40° to 210°F

#### Translucent Polypropylene

- Stain and chemical resistant
- BPA-free
- Withstands temperatures from -40° to 160°F

#### White Polyethylene

- Stain resistant
- BPA-free
- Withstands temperatures from -40° to 160°F



Clear Polycarbonate (PC)

Translucent Polypropylene (TL)



**THUNDER GROUP INC.**



#### Containers

##### Clear Polycarbonate

- PLRFT301PC
- PLRFT302PC
- PLRFT304PC
- PLRFT306PC
- PLRFT308PC
- PLRFT312PC
- PLRFT318PC
- PLRFT322PC

##### Translucent Polypropylene

- PLRFT301TL
- PLRFT302TL
- PLRFT304TL
- PLRFT306TL
- PLRFT308TL
- PLRFT312TL
- PLRFT318TL
- PLRFT322TL

##### White Polyethylene

- PLRFT301PP 1 qt
- PLRFT302PP 2 qt
- PLRFT304PP 4 qt
- PLRFT306PP 6 qt
- PLRFT308PP 8 qt
- PLRFT312PP 12 qt
- PLRFT318PP 18 qt
- PLRFT322PP 22 qt

##### White Polyethylene (PP)



#### Lids

##### Clear Polycarbonate

- PLRFC0001PC
- PLRFC0204PC
- PLRFC0608PC
- PLRFC121822PC

##### Translucent Polypropylene

- PLRFC0001TL
- PLRFC0204TL
- PLRFC0608TL
- PLRFC121822TL

##### White Polyethylene

- PLRFC0001PP Fits 1 qt
- PLRFC0204PP Fits 2 & 4 qt
- PLRFC0608PP Fits 6 & 8 qt
- PLRFC121822PP Fits 12, 18 & 22 qt

# KITCHEN

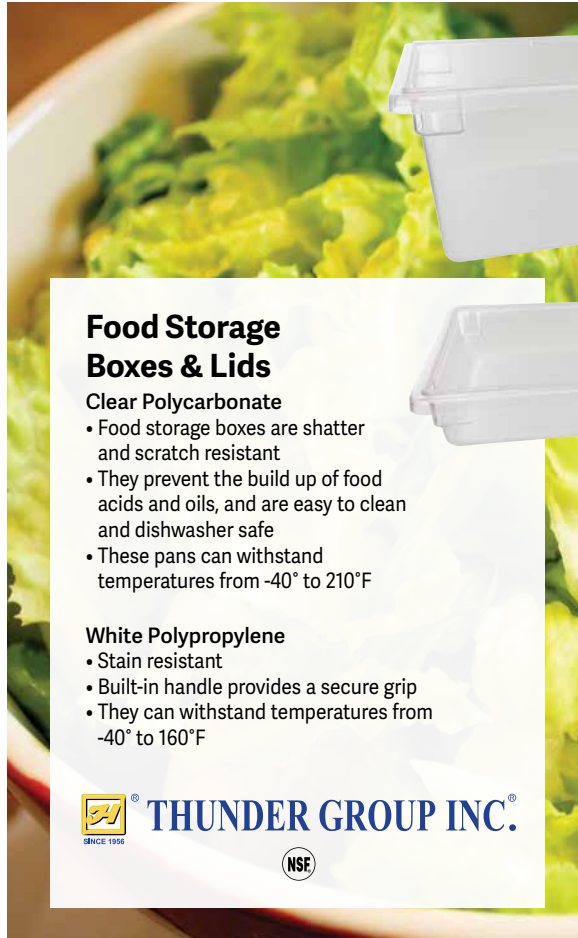

## Food Storage Boxes & Lids

### Clear Polycarbonate

- Food storage boxes are shatter and scratch resistant
- They prevent the build up of food acids and oils, and are easy to clean and dishwasher safe
- These pans can withstand temperatures from -40° to 210°F

### White Polypropylene

- Stain resistant
- Built-in handle provides a secure grip
- They can withstand temperatures from -40° to 160°F



Polycarbonate

Polypropylene

### Clear Polycarbonate

12" x 18"	
PLFB121803PC	3½" deep, 1.75 Gallon
PLFB121806PC	6" deep, 3 Gallon
PLFB121809PC	9" deep, 4.75 Gallon
PLFBC1218PC	Lid for Half-Size
PLFBD1218PC	Drain Shelf for Half-Size
18" x 26"	
PLFB182603PC	3½" deep, 5 Gallon
PLFB182606PC	6" deep, 8.75 Gallon
PLFB182609PC	9" deep, 13 Gallon
PLFB182612PC	12" deep, 17 Gallon
PLFB182615PC	15" deep, 22 Gallon
PLFBC1826PC	Lid for Full-Size
PLFBD1826PC	Drain Shelf for Full-Size

### White Polypropylene

12" x 18"	
PLFB121803PP	3½" deep, 1.75 Gallon
PLFB121806PP	6" deep, 3 Gallon
PLFB121809PP	9" deep, 4.75 Gallon
PLFBC1218PP	Lid for Half-Size
PLFBD1218PP	Drain Shelf for Half-Size
18" x 26"	
PLFB182603PP	3½" deep, 5 Gallon
PLFB182606PP	6" deep, 8.75 Gallon
PLFB182609PP	9" deep, 13 Gallon
PLFB182612PP	12" deep, 17 Gallon
PLFB182615PP	15" deep, 22 Gallon
PLFBC1826PP	Lid for Full-Size
PLFBD1826PP	Drain Shelf for Full-Size



## Flexillid™ Reusable Silicone Lids

- Use instead of plastic film wrap or foil on gastronomic and steam table pans
- Fits plastic, melamine and stainless steel pans
- Minimizes cross-contamination
- Withstands temperatures from -40° to 428°F
- Spill-proof up to half-size
- Stackable design

PLFS7000	Fits Full-Size Pans
PLFS7120	Fits Half-Size Pans
PLFS7130	Fits Third-Size Pans
PLFS7140	Fits Fourth-Size Pans
PLFS7160	Fits Sixth-Size Pans
PLFS7190	Fits Ninth-Size Pans



## Heavy-Duty Steam Table Pans

- Heavy-duty 22 gauge, 18/8 stainless steel
- Anti-jamming design
- Also available in 24 gauge stainless steel



Full Size	Depth	Capacity	Fourth Size	Depth	Capacity
ROY STP 2002H	2½"	7½ qt	ROY STP 1402H	2½"	2½ qt
ROY STP 2004H	4"	14½ qt	ROY STP 1404H	4"	3¾ qt
ROY STP 2006H	6"	22 qt	ROY STP 1406H	6"	4¾ qt
Half Size			Sixth Size		
ROY STP 1202H	2½"	4¼ qt	ROY STP 1602H	2½"	1¼ qt
ROY STP 1204H	4"	6½ qt	ROY STP 1604H	4"	2 qt
ROY STP 1206H	6"	11 qt	ROY STP 1606H	6"	2¾ qt
Third Size			Ninth Size		
ROY STP 1302H	2½"	3 qt	ROY STP 1902H	2½"	.6 qt
ROY STP 1304H	4"	4¼ qt	ROY STP 1904H	4"	1.1 qt
ROY STP 1306H	6"	6 qt			





### Elements Stainless Steel Cookware

- Ergonomic handles for comfort and ease of use
- Tri-ply base allows for even heat distribution
- Hollow, cool-touch handles
- Dome covers facilitate self-basting
- Induction ready
- Riveted handles on all pieces, including covers



KITCHEN

#### Sauté Pans with Covers

- 5734185 5 qt
- 5734187 7 qt



#### Natural Finish Fry Pans

- 5734048 8" dia
- 5734050 9½" dia
- 5734051 11" dia
- 5734052 12½" dia
- 5734054 14" dia



#### Teflon Select® Non-Stick Finish Fry Pans

- 5734058 8" dia
- 5734060 9½" dia
- 5734061 11" dia
- 5734062 12½" dia
- 5734064 14" dia



#### Sauce Pans with Covers

- 5734032 2 qt
- 5734033 3½ qt
- 5734034 4½ qt w/Helper Handle
- 5734035 5½ qt w/Helper Handle
- 5734037 7¾ qt w/Helper Handle
- 5734040 10 qt w/Helper Handle



#### Stock Pots with Covers

- |         |       |         |       |
|---------|-------|---------|-------|
| 5733908 | 8 qt  | 5733924 | 24 qt |
| 5733912 | 12 qt | 5733932 | 32 qt |
| 5733916 | 16 qt | 5733940 | 40 qt |
| 5733920 | 20 qt | 5733960 | 60 qt |



#### Braziers with Covers

- 5734014 15 qt
- 5734019 20 qt
- 5734024 25 qt
- 5734030 30 qt

# KITCHEN



## Thermalloy® Cast Iron Skilletlets

- |  |        |         |
|--|--------|---------|
| • Pre-seasoned                         | 573724 | 4" dia  |
| • PFOA/PTFE free                       | 573726 | 6" dia  |
| • Suitable for use with metal utensils | 573728 | 8" dia  |
| • Induction ready                      | 573730 | 10" dia |
|  | 573732 | 12" dia |



Ready to learn more about these great products?

**PLAY VIDEO**



## Thermalloy® Carbon Steel Fry Pans

- Perfect for unique serving of appetizers, sides or desserts
- Thick body keeps the pan from warping
- Pre-seasoned, natural finish
- Oven safe to 200°F
- Offset, riveted handle
- Induction ready

<b>Fry Pans</b>	
573735	5½" dia
573736	6⅓" dia
573738	7⅞" dia
573740	10¼" dia
573742	11⅞" dia, w/Helper Handle

<b>2-Handle Fry Pans</b>	
573745	5½" dia
573746	6⅓" dia
573748	7⅞" dia
573752	11⅞" dia, Paella



Ready to learn more about these great products?

**PLAY VIDEO**



## Tri-Gen Cookware

- Mirror finished exterior, satin interior
- Handles offer excellent comfort and control
- Triangular positioned rivets will not loosen
- Induction ready

**Winco**<sup>®</sup>



### Fry Pans - Natural or Non-Stick (NS)

TGFP-7	7" dia
TGFP-8	8" dia
TGFP-10	10" dia
TGFP-12	12" dia
TGFP-14	14" dia

### Sauce Pans w/Covers

TGAP-2	1.5 qt
TGAP-3	2.5 qt
TGAP-4	3.5 qt
TGAP-5	4.5 qt
TGAP-7	7 qt

### Sauté Pans w/Covers

TGET-2	2 qt
TGET-3	3 qt
TGET-6	6 qt
TGET-7	7 qt

### Stock Pots w/Covers

TGSP-4	4.5 qt
TGSP-6	6 qt
TGSP-8	8 qt
TGSP-12	12 qt
TGSP-16	16 qt
TGSP-20	20 qt

### Braziers w/Covers

TGBZ-12	12 qt
TGBZ-14	14 qt



Non-Stick Finish  
Fry Pan



Natural Finish  
Fry Pan



Sauté Pans  
w/Covers



Braziers  
w/Covers



Stock  
Pots  
w/Covers



Sauce Pans  
w/Covers

## Aluminum Stock Pots

- Medium weight aluminum
- Straight sided
- Riveted handles

**ROYAL**<sup>®</sup>  
**INDUSTRIES**  
Foodservice & Hospitality Products

ROY RSPT 8 M	8 qt	ROY RSPT 50 M	50 qt
ROY RSPT 12 M	12 qt	ROY RSPT 60 M	60 qt
ROY RSPT 16 M	16 qt	ROY RSPT 80 M	80 qt
ROY RSPT 20 M	20 qt	ROY RSPT 100 M	100 qt
ROY RSPT 24 M	24 qt	ROY RSPT 120 M	120 qt
ROY RSPT 30 M	30 qt	ROY RSPT 140 M	140 qt
ROY RSPT 40 M	40 qt	ROY RSPT 160 M	160 qt



# KITCHEN



## Staub® Cast Iron Round Cocottes

- Superior cooking surface, self-basting lids, exceptional durability, and beauty
- These uniquely glossy, majolica enamels boast deep, intense shades and beautiful color
- Also available in Black, Grenadine, Dark Blue and Gray

1102406	4 qt, Cherry
1102606	5½ qt, Cherry
1102806	7 qt, Cherry
1103006	9 qt, Cherry



ZWILLING  
J.A.HENCKELS



## Staub® Cast Iron Mini Cookware

- Black matte enameled finish
- Pack of 6

19501025	Round Cocotte, ¼ qt
19511625	Round Roasting Dish, ½ qt



ZWILLING  
J.A.HENCKELS

## Slide Check Racks

- Aluminum w/glass marbles
- One handed check operation
- Includes mounting screw pack
- ¾"d x 2"h



**san jamar**  
smart. safe. sanitary.

CK6512A	12"w	CK6536A	36"w
CK6518A	18"w	CK6548A	48"w
CK6524A	24"w	CK6560A	60"w

## BestGrip™ Oven Mitts

- Made of non-slip textured material that always looks clean
- Up to 500°F heat protection for 60 seconds
- Rinse in sink or wipe clean easily with damp cloth
- Integrated magnet allows for easy storage
- Tan/Black



810CM15	15" long
810CM17	17" long



**san jamar**  
smart. safe. sanitary.

## The "Rotissi-Glove"

- Fully insulated with cotton flocked inner lining
- Up to 500°F heat protection for 15 seconds
- Made with super heat-resistant Neoprene™ rubber
- USDA accepted
- One size fits all



T1212	Pair, 12" long
T1217	Pair, 17" long



## Pan Grabber

- Baker's pad with wrist strap
- Extra-thick layer of terry cloth outside and a Bestex™ interior
- Inner steam barrier for extra protection
- Protects to 400°F for 15 seconds
- Machine washable



803PG	9½" x 11"
-------	-----------

## BestGuard® Oven Mitts

- Fire-retardant – protects to 450°F for 30 seconds
- Wipes clean with a damp cloth
- Tan or Black (BK)
- One size fits all



800FG13	13" long
800FG15	15" long
800FG17	17" long

**san jamar**  
smart. safe. sanitary.

WebGuard™ for extra protection and comfort between thumb and forefinger.

## KitchenGrips® Pro Heat Protection

- Made using exclusive FLXa-Prene™ flexible, non-porous material
- Protection from -134° to 482°F (with intermittent contact)
- Water-repellent and stain-resistant
- Safe non-slip grip
- Black



### Oven Mitts

- |            |   |
|------------|---|
| A. 5431202 | Oven Mitt, 10¾" long                                    |
| 5431502    | Oven Mitt, 13¾" long                                    |
| 5431802    | Oven Mitt, 16¾" long                                    |
| B. 5432202 | Oven Mitt w/Nomex® Binding, 10¾" long                   |
| 5432502    | Oven Mitt w/Nomex® Binding, 13¾" long                   |
| 5432802    | Oven Mitt, w/Nomex® Binding, 16¾" long                  |
| C. 5443602 | Three Finger Oven Mitt w/Nomex® Binding, 16¾" long      |
| D. 5434102 | Puppet Oven Mitt, 15" long                              |
| 5434202    | Puppet Oven Mitt, 17" long                              |
| 5443502    | Deluxe Puppet Oven Mitt w/Nomex® Binding, Palm 15" long |

### Hot Pads

- |            |                                |
|------------|--------------------------------|
| E. 5442002 | Ultra-Thick Hot Pad, 7"        |
| 5442102    | Ultra-Thick Hot Pad, 10"       |
| F. 5437102 | Safe Server Finger Hot Pad, 7" |
| G. 5436102 | Hot Pad, 7"                    |
| 5436502    | Hot Pad, 10"                   |

### Pan Handle Sleeve

- |            |                            |
|------------|----------------------------|
| H. 5439002 | Pan Handle Sleeve, 6" long |
|------------|----------------------------|

Ready to learn more about these great products?

**PLAY VIDEO**



## Flame-Resistant Pyrotex® Oven Mitts

- 100% cotton fill on the inside
- Seams sewn with KEVLAR® thread
- Lab-tested insulation to 450°F
- Machine washable
- Beige

- |           |                          |
|-----------|--------------------------|
| 2PX25BETF | Forearm Length, 15" long |
| 2PX27BETF | Elbow Length, 17" long   |



## Non-Stick Silicone Oven Mitt

- Won't stick to frozen foods
- Lab-tested to 350°
- Wipe clean, machine washable
- Silver

- |         |                        |
|---------|------------------------|
| OMS26SL | Elbow Length, 16" long |
|---------|------------------------|



## Ritz® 685° Silicone Oven Mitts

- Solid silicone exterior
- Flame and heat resistant up to 685°F
- 100% cotton terry soft touch interior is quick drying
- Dishwasher safe and bleach resistant
- Black

Unique tread design for better grip



- |            |          |
|------------|----------|
| RZS685BK17 | 17" long |
|------------|----------|



## Steam Stopping Terry Pan Grabber

- Thick terry outside, 100% cotton fill with steam stopping vinyl in the middle
- Protects up to 450°F
- Machine washable
- Beige

- |       |          |
|-------|----------|
| PG1-2 | 8" x 11" |
|-------|----------|



# KITCHEN

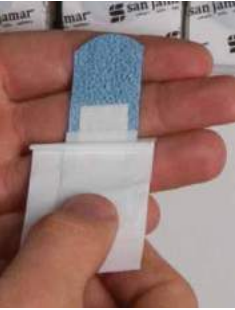

## Mani-Kare® Bandage Dispenser & Refills

- One-at-a-time dispensing to reduce waste
- Pilferage resistant locked upper compartment
- Simple, one-handed operation
- Wall-mounted to save space
- Bandage dispenser includes:
  - (1) Large Patch Bandage Cartridge
  - (1) Knuckle Bandage Cartridge
  - (3) Strip Bandage Cartridges
  - (1) Quick User Guide
  - (1) Screw Pack



- MKBD100 Bandage Dispenser, 12"w x 2"d x 6 3/8"h  
 MKBR901 1" x 3" Strip Bandage Refill Cartridge (3 Cartridges of 15)  
 MKBR903 1 1/2" x 3" Knuckle Bandage Refill Cartridge (3 Cartridges of 10)  
 MKBR905 2" x 3" Large Patch Bandage Refill Cartridge (3 Cartridges of 10)

Blue bandages are easy to detect, helping avoid serving contaminated food



## Dishwashing Apron

- Waterproof and tough, made of sturdy vinyl
- Extra long so dishwashers stay dry
- Easily wipes and rinses clean

OSVA 34"w x 47"l



## Dishwashing Aprons

- Water resistant
- Black

BA-HN

- BA-HN Heavy Vinyl w/Pocket, 41 1/4"l x 26 1/2"w  
 BA-LA Latex, 44 1/2"l x 37"w



## Dishwashing Aprons

- Water resistant

- Black  
 BAW-2540BK Lightweight Nylon, 40"l x 25 1/2"w  
 Brown  
 BAW-2740BN Heavyweight Vinyl, 40"l x 27 1/2"w

BAW-2540BK

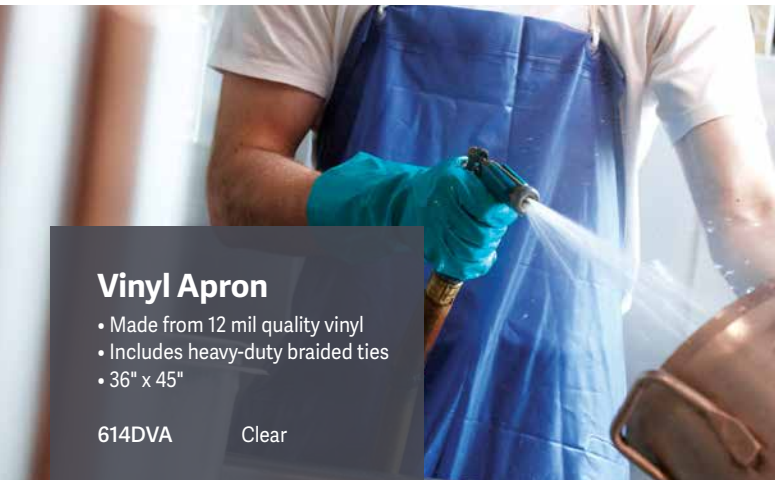

## Vinyl Apron

- Made from 12 mil quality vinyl
- Includes heavy-duty braided ties
- 36" x 45"

614DVA Clear



## Nitrile Dishwashing Gloves

- Made with super tough, flexible and extremely heat-resistant nitrile rubber
- 22 mil thickness
- USDA accepted
- 19" long
- Green

19NU S, M, L, XL





### X3® Black Nitrile Gloves

- Powder free
- Textured exterior, beaded cuff
- Black

BX342100	Small
BX344100	Medium
BX346100	Large
BX348100	X-Large
BX349100	2X-Large



### GPX3® Vinyl Gloves

- Powder free
- Smooth exterior, beaded cuff
- Clear

GPX342100	Small
GPX344100	Medium
GPX346100	Large
GPX348100	X-Large



### Disposable Foodservice Gloves

- Powder free polyethylene
- Embossed exterior, non-beaded cuff
- Clear

PGLOVE-S	Small
PGLOVE-M	Medium
PGLOVE-L	Large



### LX3® Ivory Latex Gloves

- Utilizes innovative thinwall technology that gives strength, flexibility and comfort
- Textured for a slip-free grip
- Powder free
- 100 gloves per box
- Ivory

LX342100	Small
LX344100	Medium
LX346100	Large
LX348100	Extra Large



### X3® Nitrile Gloves

- Powder free
- Textured exterior, beaded cuff
- Blue

X342100	Small
X344100	Medium
X346100	Large
X348100	X-Large
X349100	2X-Large



### X3 Ultra Blue Nitrile Gloves

- Industrial grade nitrile
- Textured fingers for a slip-free grip
- Powder free
- Beaded cuff
- Blue

XUNPF42100	Small
XUNPF44100	Medium
XUNPF46100	Large
XUNPF48100	Extra Large



KITCHEN

# KITCHEN



## Bib Apron

- 65/35 poly-cotton blend
- 2 waist pockets, designed to hold digital tablets up to 8" wide
- 33½"l x 27"w

BA-3427CS Chalkstripe

**winco**®



BA-3327B

## Bourbon Bib Aprons

- Poly/cotton blend
- Adjustable snap-button neck strap
- Thermometer/pen pocket
- 8 waist pockets
- 33½"l x 27"w

BA-3327B Blue  
BA-3327K Black



UNF-9K

## Broadway Ventilated Shirts

- Universal fit
- Lightweight 65/35 poly-cotton blend
- Cool mesh panels on back, sides and underarms
- Stand-up collar
- Chest pocket
- Thermometer pocket on sleeve
- Available in sizes Small to 2X-Large

UNF-9K Black  
UNF-9W White



## Pill Box Hat with Mesh Top

- Black mesh top
- Elastic band on top
- Machine washable
- Available in Regular (20" to 22") and XL (22" to 23½")

H008-R Black



← Tapered fit for unrestricted movement

## Extra Coverage Kitchen Apron

- Extra coverage eliminates dirty shirts
- Raised waistline means no need to fold
- Long shoelace style strings are easy to tie in front
- Large 11½" neckline for more comfort
- Aprons can be embroidered
- Sizes XS-L
- 32"w x 32½"l

BIAWH



## Baseball Caps

- 100% cotton
- Adjustable headband
- Embroidered Chef logo
- One size fits most

H064BK Black Hat w/White Logo

## Waist Apron

- 100% spun polyester
- Soft, strong fabric dries quickly and won't fade
- Bleach-safe
- 4 pockets (3 pockets & pen pocket)

3PWAC-BK 20½" x 12"







### Crew Chef Jacket

- Double breasted with a traditional collar
- Long sleeve
- Poly-cotton blend
- Thermometer/pen pocket
- Black logo buttons

J061BK XS-5X, Black



### Ladies Corporate Jacket

- Side-slit allows for better fit and ease of movement
- Cloth covered buttons
- White chef jacket
- Black piping

LJ008 XS-XL, White



KITCHEN

Made of Cheftex™ – a new high performance poly-cotton

## Quality & Value!

Designed for strength, these versatile chef pants provide plenty of comfort with an elastic waist and baggy fit



### Baggy Style Chef Pants

- 2" elastic waist with drawstring
- Durable poly-cotton
- 2 side and 2 rear pockets

P020BK XS-8X, Black



### Crew Fresh Jacket

- Poly-cotton blend
- ¾ length sleeve jackets are stylish, cool, and comfortable from the kitchen to the front of the house
- Thermometer/pen pocket
- Flat black plastic chef logo buttons
- Black trim

J134TM XS-5X, Tomato Red

# STORAGE & TRANSPORT



## Stackable Shelf Ingredient Bins

- Transparent, polycarbonate lift-and-slide lid with a polypropylene body
- Stackable
- One-handed access — even when stacked
- Scoop with dedicated clip to ensure sanitation compliance

IB-2S 2 gal, 40 Cup Capacity  
 IB-5S 5 gal, 80 Cup Capacity  
 IB-10S 10 gal, 150 Cup Capacity



## Ingredient Bins

- Advanced super clasp lid design makes it easy to scoop ingredients without removing the entire cover
- Scoop handle designed to remain out of food to prevent contamination
- 3" caster wheels with brakes

IB-21 21 gal, 159 lb Sugar, 124 lb Flour  
 IB-27 27 gal, 197 lb Sugar, 154 lb Flour



## Ingredient Bins w/Scoop

- Shelf bins have a clear flip top lid
- Mobile ingredient bins have 3" casters (2 locking) and clear sliding lids
- Include a scoop with built-in hook
- Dishwasher safe
- Polypropylene material

### Shelf Bins

PLIB002S 2 gal, 40 Cup Capacity  
 PLIB005S 5 gal, 80 Cup Capacity  
 PLIB010S 10 gal, 150 Cup Capacity

### Mobile Bins w/Casters & Scoop

PLIB021C 21 gal, 160 lb Sugar, 126 lb Flour  
 PLIB027C 27 gal, 197 lb Sugar, 154 lb Flour



## ProSave® Shelf Ingredient Bins w/Scoop

- Sliding lid for one-handed access
- Design allows scoop (included) to hook inside the bin, but away from the product - improving food safety
- Dishwasher safe
- 3" casters on mobile bins



### Shelf Bins

FG9G6000 WHT 40 Cup Capacity, ½ Cup Scoop  
 FG9G5700 WHT 100 Cup Capacity, 2 Cup Scoop  
 FG9G5800 WHT 200 Cup Capacity, 2 Cup Scoop

### Mobile Bins w/32 oz Scoop

FG360088 WHT 20.5 gal, 124 lb Flour, 158 lb Sugar  
 FG360288 WHT 26.2 gal, 154 lb Flour, 197 lb Sugar  
 FG360388 WHT 30.8 gal, 188 lb Flour, 240 lb Sugar

### Mobile Rack

FG9G7900CHRM 3 Shelves, Chrome, 38" w x 18" l x 48.3" h



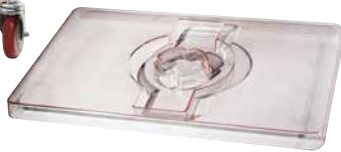

Plastic Cover

### Triple Ingredient Bin

- Heavy-duty plastic bins are constructed of seamless, one-piece, sanitary polyethylene
- Will not chip, corrode or rust
- Clear, heavy-duty, plastic lids

- Heavy-duty frame is constructed of sanitary aluminum that will not rust and maneuvers easily on large 5" casters

148PIB 17"w x 31½"l x 28¾"h

### Ingredient Bins

- Convenient slide back lid for easy access
- The bin body is made of FDA-accepted poly so no liners are needed
- Polycarbonate lids are transparent to easily identify the contents
- 3" casters, 2 fixed and 2 swivel



IBS27

IBSF27



### Slant Top

IBS20 21 gal, Holds 170 lb Sugar or 140 lb Flour

IBS27 27 gal, Holds 226 lb Sugar or 150 lb Flour

IBS37 37 gal, Holds 314 lb Sugar or 225 lb Flour

### Flat Top

IBSF27 26.7 gal, Holds 216 lb Sugar or 150 lb Flour

### Camshelving® Starter Units

- Flexible enough to fit into any space, easy to assemble, adjust or configure
- Easily wipes clean and shelf plates are dishwasher safe
- Withstands temperatures as cold as -36° to 190°F
- Comes with 4 vented shelves and 4 posts
- 800 lb capacity per shelf for 36" to 48" shelves
- 600 lb capacity per shelf for 54" and 60" shelves
- 72" high

#### Basics Plus Starter Units

- For light to medium storage needs (2-5 deliveries per week)
- Available in Brushed Graphite (580)

#### Elements Starter Units

- For medium to heavy storage needs (5-7 deliveries per week)
- Available in Brushed Graphite (580)

#### Premium Starter & Add-On Units

- For heavy storage needs (daily deliveries)
- Shelves include Camguard™ antimicrobial that inhibits the growth of mold, fungus and bacteria
- Available in Speckled Gray (480)



#### Basics Plus Starter Units

18"w	21"w	24"w	Length
CBU183672V4	CBU213672V4	CBU243672V4	36"
CBU184272V4	CBU214272V4	CBU244272V4	42"
CBU184872V4	CBU214872V4	CBU244872V4	48"
CBU185472V4	CBU215472V4	CBU245472V4	54"
CBU186072V4	CBU216072V4	CBU246072V4	60"

Additional post kits, shelf kits, add-on units, corner units, casters and accessories are also available.

#### Elements Starter Units

18"w	21"w	24"w	Length
ESU183672V4	ESU213672V4	ESU243672V4	36"
ESU184872V4	ESU214872V4	ESU244872V4	48"
ESU186072V4	ESU216072V4	ESU246072V4	60"

#### Premium Starter Units

18"w	24"w	Length
CPU183672V4	CPU243672V4	36"
CPU184872V4	CPU244872V4	48"

#### Premium Add-On Units

18"w	24"w	Length
CPA183672V4	CPA243672V4	36"
CPA184872V4	CPA244872V4	48"



### Security Cage

- Provides safe storage for valuables (wine, champagne and spirits, etc.)
- Ideal for securing personal items (purses and backpacks, etc.)
- Unique modular design retrofits one shelf at a time or an entire shelving unit
- Fits on 24" x 48" Camshelving®

CSSC244818 42½"l x 25¼"w x 18"h



# STORAGE & TRANSPORT

## EP Series Wire Shelving

- Unique design offers high volume and easily accessible storage
- Open wire truss reinforced shelves feature front to back welded surface ribs
- Increases light penetration, free air circulation and merchandise visibility
- Posts are numbered

- Shelves adjust on 1" increments
- 600-800 lb capacity per shelf
- For both wet or dry applications
- 7 year warranty against rust and corrosion



## Silver EP Series

- Silver epoxy powder coat over a rust-inhibiting undercoat

14"w	18"w	21"w	24"w	Length	PK
S1424EP	S1824EP	S2124EP	S2424EP	24"	4
S1430EP	S1830EP	S2130EP	S2430EP	30"	4
S1436EP	S1836EP	S2136EP	S2436EP	36"	4
S1442EP	S1842EP	S2142EP	S2442EP	42"	4
S1448EP	S1848EP	S2148EP	S2448EP	48"	4
S1454EP	S1854EP	S2154EP	S2454EP	54"	2
S1460EP	S1860EP	S2160EP	S2460EP	60"	2
S1472EP	S1872EP	S2172EP	S2472EP	72"	2

## Silver EP Series

### Extra-Wide Shelves

30"w	36"w	Length	PK
S3036EP	S3636EP	36"	2
S3048EP	S3648EP	48"	2
S3060EP	S3660EP	60"	2
S3072EP	S3672EP	72"	2

## Black EP Series

- Black epoxy powder coat over a rust-inhibiting undercoat
- High gloss epoxy finish



18"w	24"w	Length	PK	18"w	24"w	Length	PK
S1824B	S2424B	24"	4	S1848B	S2448B	48"	4
S1830B	S2430B	30"	4	S1854B	S2454B	54"	2
S1836B	S2436B	36"	4	S1860B	S2460B	60"	2
S1842B	S2442B	42"	4	S1872B	S2472B	72"	2

## Poly-Z-Brite™

- Features a true powder-epoxy over zinc-chromate electro-plating that ensures a strong, durable finish
- Resembles the look of chrome
- Protected by Nexguard™, an anti-microbial agent that protects the coating from bacteria, mold and mildew
- 15 year warranty against rust and corrosion

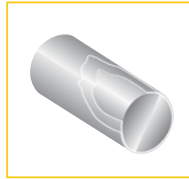

14"w	18"w	21"w	24"w	Length	PK
S1424Z	S1824Z	S2124Z	S2424Z	24"	4
S1430Z	S1830Z	S2130Z	S2430Z	30"	4
S1436Z	S1836Z	S2136Z	S2436Z	36"	4
S1442Z	S1842Z	S2142Z	S2442Z	42"	4
S1448Z	S1848Z	S2148Z	S2448Z	48"	4
S1454Z	S1854Z	S2154Z	S2454Z	54"	2
S1460Z	S1860Z	S2160Z	S2460Z	60"	2
S1472Z	S1872Z	S2172Z	S2472Z	72"	2

## Posts

- Rugged 1" dia steel posts are grooved and numbered at 1" increments

- Includes floor leveler and plastic post cap
- Pk 4 ea

Poly-Z-Brite	Silver	Black	Length	Poly-Z-Brite	Silver	Black	Length
P6Z	P6EP	P6B	6"	P63Z	P63EP	P63B	63"
P14Z	P14EP	P14B	14"	P66Z	P66EP	P66B	66"
P34Z	P34EP	P34B	34"	P74Z	P74EP	P74B	74"
P54Z	P54EP	P54B	54"	P86Z	P86EP	P86B	86"



*Easily adjustable and expandable—no tools required*

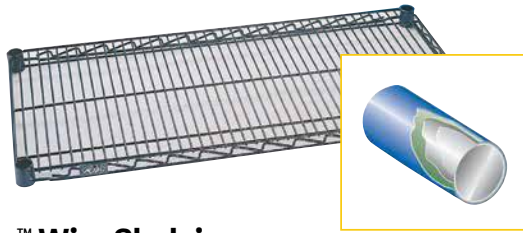

## Nexelon™ Wire Shelving

- Top of the line finish
- Replace stainless steel with Nexelon™ to increase the life of your storage system and reduce its cost
- Protected by Nexguard™, an anti-microbial agent
- Use throughout your facility, handles all environmental conditions
- Limited lifetime warranty against rust and corrosion

14"w	18"w	21"w	24"w	Length	PK
S1424N	S1824N	S2124N	S2424N	24"	4
S1430N	S1830N	S2130N	S2430N	30"	4
S1436N	S1836N	S2136N	S2436N	36"	4
S1442N	S1842N	S2142N	S2442N	42"	4
S1448N	S1848N	S2148N	S2448N	48"	4
S1454N	S1854N	S2154N	S2454N	54"	2
S1460N	S1860N	S2160N	S2460N	60"	2
S1472N	S1872N	S2172N	S2472N	72"	2

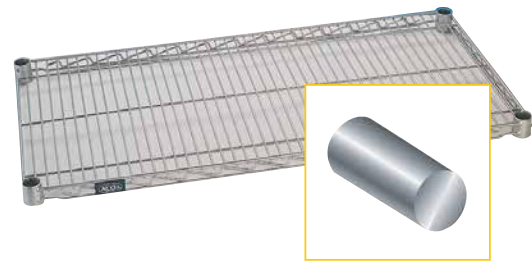

## Stainless Steel Wire Shelving

- Provides stability and durability with a smooth, attractive electro polished finish
- Handles moisture and temperature extremes
- Resists rust and corrosion
- Limited lifetime warranty against rust and corrosion

18"w	24"w	Length	PK
S1836S	S2436S	36"	4
S1848S	S2448S	48"	4
S1860S	S2460S	60"	2
S1872S	S2472S	72"	2



## Chrome Wire Shelving

- Electro-plated nickel chrome, resulting in a brilliant gloss finish
- Perfect for display and dry storage
- Limited 1 year warranty against rust and corrosion

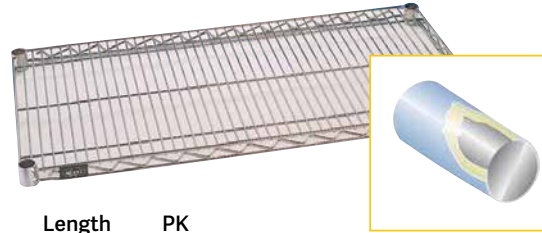

14"w	18"w	21"w	24"w	Length	PK
S1424C	S1824C	S2124C	S2424C	24"	4
S1430C	S1830C	S2130C	S2430C	30"	4
S1436C	S1836C	S2136C	S2436C	36"	4
S1442C	S1842C	S2142C	S2442C	42"	4
S1448C	S1848C	S2148C	S2448C	48"	4
S1454C	S1854C	S2154C	S2454C	54"	2
S1460C	S1860C	S2160C	S2460C	60"	2
S1472C	S1872C	S2172C	S2472C	72"	2

## Chrome Wire Shelving

### Extra-Wide Shelves

30"w	36"w	Length	PK
S3036C	S3636C	36"	2
S3048C	S3648C	48"	2
S3060C	S3660C	60"	2
S3072C	S3672C	72"	2

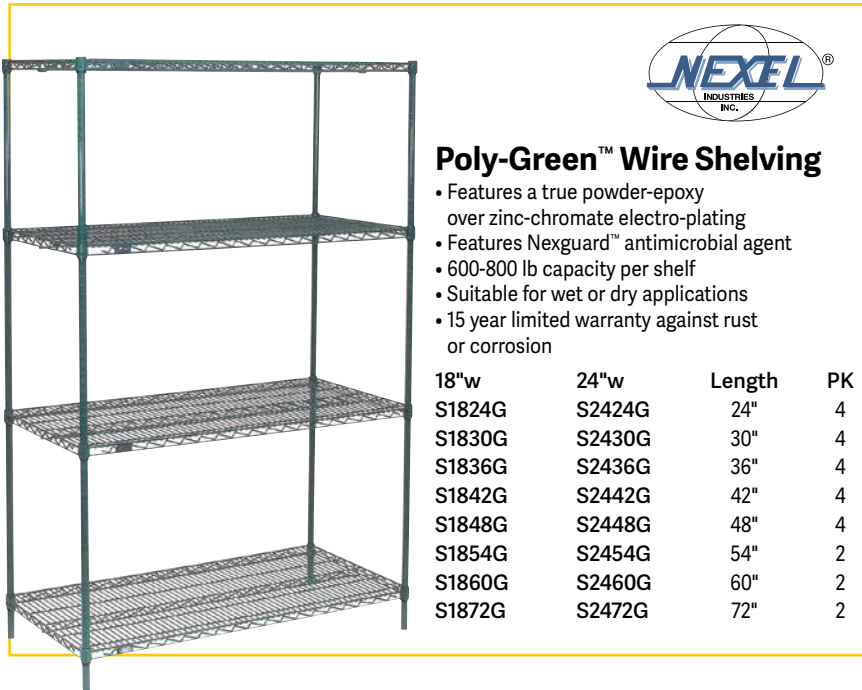

## Poly-Green™ Wire Shelving

- Features a true powder-epoxy over zinc-chromate electro-plating
- Features Nexguard™ antimicrobial agent
- 600-800 lb capacity per shelf
- Suitable for wet or dry applications
- 15 year limited warranty against rust or corrosion

18"w	24"w	Length	PK
S1824G	S2424G	24"	4
S1830G	S2430G	30"	4
S1836G	S2436G	36"	4
S1842G	S2442G	42"	4
S1848G	S2448G	48"	4
S1854G	S2454G	54"	2
S1860G	S2460G	60"	2
S1872G	S2472G	72"	2

## Posts

- Rugged 1" dia steel posts are grooved and numbered at 1" increments
- Includes floor leveler and plastic post cap
- Pk 4 ea

Poly Green	Chrome	Nexelon	Stainless Steel	Length
P6G	P6C	P6N	-	6"
P14G	P14C	P14N	-	14"
P34G	P34C	P34N	-	34"
P54G	P54C	P54N	-	54"
P63G	P63C	P63N	P63S	63"
P66G	P66C	P66N	-	66"
P74G	P74C	P74N	P74S	74"
P86G	P86C	P86N	P86S	86"
-	P96C	-	-	96"

# STORAGE & TRANSPORT



## Wire Shelving Units

- Open wire design maximizes light and air circulation to keep storage dry and ventilated
- Simply snap together and slide shelf over clips for positive locking
- 400 lb capacity shelves adjust on 1" increments
- Green and Black epoxy finishes are ideal for both wet and dry applications, with a 7 year limited warranty against rust



Zinc Chromate	Green Epoxy	Black Epoxy	
VP18367ZC	VP18367G	VP18367B	18" x 36" x 74"
VP18487ZC	VP18487G	VP18487B	18" x 48" x 74"
VP24367ZC	VP24367G	VP24367B	24" x 36" x 74"
VP24487ZC	VP24487G	VP24487B	24" x 48" x 74"

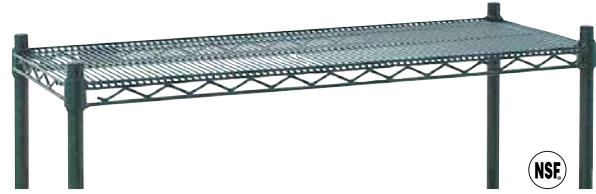

## Wire Shelving, Brackets & Posts

- Green epoxy coated - all environment
- Capacity: 600 to 800 lb per shelf - maximum 2,000 lb per unit

Shelves - plastic mounting sleeves included

14"w	Length
ROY AE S ZGN 1424	24"
ROY AE S ZGN 1430	30"
ROY AE S ZGN 1436	36"
ROY AE S ZGN 1442	42"
ROY AE S ZGN 1448	48"
ROY AE S ZGN 1460	60"
ROY AE S ZGN 1472	72"
ROY AE S ZGN 1824	24"
ROY AE S ZGN 1830	30"
ROY AE S ZGN 1836	36"
ROY AE S ZGN 1842	42"
ROY AE S ZGN 1848	48"
ROY AE S ZGN 1860	60"
ROY AE S ZGN 1872	72"
ROY AE S ZGN 2424	24"
ROY AE S ZGN 2430	30"
ROY AE S ZGN 2436	36"
ROY AE S ZGN 2442	42"
ROY AE S ZGN 2448	48"
ROY AE S ZGN 2460	60"
ROY AE S ZGN 2472	72"

Posts - post leveler included

ROY AE P ZGN 13	13"h
ROY AE P ZGN 34	34"h
ROY AE P ZGN 54	54"h
ROY AE P ZGN 63	63"h
ROY AE P ZGN 74	74"h
ROY AE P ZGN 86	86"h

Wall Brackets

ROY WB 14 ZGN	14"
ROY WB 18 ZGN	18"
ROY WB 24 ZGN	24"



## Keg & Pail Cart

- Easily moves barrels of beer
- Helps eliminate back strain
- Powder-coated steel construction
- Made in the USA

KPC-100 8" Roller Bearing Wheels

Ready to learn more about these great products?

**PLAY VIDEO**



## Keg & Pail Dolly

- Heavy-duty all metal construction moves beer kegs and locks onto most sizes of trash cans
- Made in USA

DOL-100 400 lb Capacity



## Universal Shelving Casters

- Heavy-duty polyurethane non-marking casters
- 250 lb load capacity per caster
- Set of four 5" wheels, 2 braking

FCAST5 Fit 1" Posts



## Universal Shelving Casters

- Grease resistant wheels
- 220 lb load capacity per caster
- Set of four 5" wheels w/brakes

28-151S Fit 1" Posts



## Wire Shelves

- 600-800 lb capacity per shelf
- All welded construction with additional wire trussing for high strength characteristics
- No tools required for assembly
- Adjustable foot levelers
- 12", 14", 21", 30" and 36" widths also available in most finishes
- Add suffix for finish: Chrome (C), Black Epoxy (BK), Gray Epoxy (GY) or Green Epoxy (P)

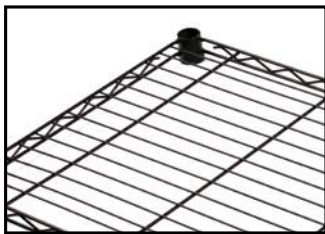

Black Epoxy finish

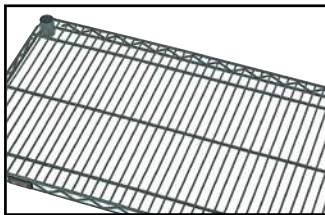

Green Epoxy finish



Gray Epoxy finish

### 18"d Shelves

Length	1824	1830	1836	1842	1848	1854	1860	1872
24"								
30"								
36"								
42"								
48"								
54"								
60"								
72"								

### 24"d Shelves

Length	2424	2430	2436	2442	2448	2454	2460	2472
24"								
30"								
36"								
42"								
48"								
54"								
60"								
72"								



## Finishes

**Chrome** - is electro-plated over a copper nickel with a high glossy finish. Perfect for the front of the house, and the most popular finish. Limited 1 year against rust and corrosion in dry storage applications.



**Stainless Steel** - type 304 provides stability and durability with a smooth, attractive, electro-polished surface. The best choice for corrosive, high humidity or clean room environments. Lifetime limited warranty against rust and corrosion.



**Green and Gray Epoxy** - can be used in any wet or dry application. Includes an antimicrobial agent that protects the epoxy coating from bacteria, mold, and mildew that causes stains, odors and product degradation. 15 year limited warranty for antimicrobial finish to not rust or corrode.



**Black Epoxy** - can be used in any wet or dry application. Includes an antimicrobial agent that protects the epoxy coating from bacteria, mold, and mildew that causes stains, odors and product degradation. 15 year limited warranty for antimicrobial finish to not rust or corrode.



## Solid Shelves

- Dual layer construction with double hemmed perimeter
- Marine edge ensures maximum strength while retaining spillage and excellent corrosion resistance
- Add suffix for finish: Solid Galvanized (SG) and Stainless Steel (SS)

18"d Shelves	24"d Shelves	Length
1824	2424	24"
1830	2430	30"
1836	2436	36"
1842	2442	42"
1848	2448	48"
1854	2454	54"
1860	2460	60"
1872	2472	72"

## Posts

- Add suffix for finish: Chrome (C), Black Epoxy (BK), Gray Epoxy (GY) or Green Epoxy (P)

P6	6"h		Chrome Finish
P14	14"h		Black Epoxy Finish
P34	34"h		Gray Epoxy Finish
P54	54"h		Green Epoxy Finish
P63	63"h		
P74	74"h		
P86	86"h		
P96	96"h		



## Plastic Shelving Kits with Metal Posts

- Each shelf supports up to 600 lb
- Shelving kits include: 4 open-grid plastic shelves, 4 steel posts with blue anti-bacterial finish & 4 packs of split sleeves
- 72"h

RPWR72-1830E	18" x 30"
RPWR72-1836E	18" x 36"
RPWR72-1848E	18" x 48"
RPWR72-2430E	24" x 30"
RPWR72-2436E	24" x 36"
RPWR72-2448E	24" x 48"
RPWR72-2460E	24" x 60"



# STORAGE & TRANSPORT



WRC-1836BK-3  
Black Epoxy Wire



WRC-1836-2CG  
Chrome Wire & Solid Galvanized



WRSC-1836-3SS  
Solid Stainless Steel



## Wire Utility Carts

- Versatile carts available in a variety of configurations to suit your needs
- Choose carts with 2 or 3 shelves in all wire, all solid galvanized steel or stainless steel, or a combination of 1 or 2 wire shelves with 1 solid shelf
- Wire shelves come in 4 different finishes: Chrome, Green Epoxy, Black Epoxy or Gray Epoxy
- Carts include 2 u-handles, 4 donut bumpers and 4 swivel casters (2 braking)

All configurations available in these sizes:

- 18" w x 36" l x 37½" h
- 18" w x 42" l x 37½" h
- 18" w x 48" l x 37½" h
- 24" w x 36" l x 37½" h
- 24" w x 42" l x 37½" h
- 24" w x 48" l x 37½" h



Green Epoxy finish



## Stem Castered Security Carts

- Mobile security carts with Chrome Finish (C)
- Includes 4 posts, 2 wire shelves, 1 security panel set, 1 pair security panel doors
- 24" w x 69" h
- Also available with Green Epoxy finish (P)

- M2436-69SEC 36" long
- M2448-69SEC 48" long
- M2460-69SEC 60" long

## Stationary Security Carts

- Chrome finish
- Includes 4 posts, 2 wire shelves, 1 security panel set and 1 pair security panel doors
- 24" w x 63" h

- 2436-63SEC 36" long
- 2448-63SEC 48" long
- 2460-63SEC 60" long

## Dolly Base Security Carts

- Chrome finish
- Includes 4 posts, 2 wire shelves, 1 security panel set, 1 pair security panel doors, 1 dolly base and 4 plate casters
- 24" w x 70" h

- MD2436-70SEC 36" long
- MD2448-70SEC 48" long
- MD2460-70SEC 60" long





## Security Trucks

- Compact size makes it ideal for permanent inventory storage
- Lockable doors prevent items from falling out of truck while in transit
- Includes 5" polyurethane wheel swivel casters and dolly base

- Optional E-Z Adjuster Shelves allow for shelf adjustment, removal or addition without disassembling the entire unit
- Available in Chrome or Poly-Z-Brite finish
- 1200 lb capacity
- 69" high

### Security Trucks

Poly-Z-Brite	Chrome	W x L
-	STS1836C	18" x 36"
-	STS1848C	18" x 48"
STS2436Z	STS2436C	24" x 36"
STS2448Z	STS2448C	24" x 48"
STS2460Z	STS2460C	24" x 60"

### Optional E-Z Adjuster Interior Shelves

Poly-Z-Brite	Chrome	W x L
-	S1836AC	18" x 36"
-	S1848AC	18" x 48"
S2436AZ	S2436AC	24" x 36"
S2448AZ	S2448AC	24" x 48"
S2460AZ	S2460AC	24" x 60"



STORAGE & TRANSPORT



## Service Carts

- Sturdy, lightweight and ergonomically designed
- Durable, stain-resistant surface
- Knocked down design
- Polypropylene shelves, lightly textured to reduce sliding
- Colors: Speckled Gray (480), Black (110)

BC331KD 300 lb Capacity, 32 $\frac{1}{2}$ "l x 16 $\frac{1}{4}$ "d x 38"h  
 BC340KD 400 lb Capacity, 40"l x 21 $\frac{1}{4}$ "d x 37 $\frac{1}{2}$ "h

**CAMBRO**  
 TRUSTED FOR GENERATIONS™



## Your Shelving Needs!

Unlike traditional carts that have fixed heights, these wire shelving carts are height-adjustable to fit your storage needs.

<http://www.winco.us>



## 3-Tier Wire Shelving Carts

- Includes three adjustable-height shelves
- Capacity up to 800 lb
- Step-lock feature on two casters
- Ships knocked down

VCCD-1836B 18" x 36"  
 VCCD-2448B 24" x 48"

**Winco**®

# STORAGE & TRANSPORT



WL-66



WL-618

## Multi-Tier Lockers

- Ideal for all types of facilities: retail, industrial, supermarket, foodservice, schools and government agencies
- Opens with door pulls and will accept padlock (not included)
- Can be used with flat key (not included) for positive latching
- The grid system allows clear identification of personal items for security
- Unit height is 78" and column width is 12"
- 10" w x 12" d x 12" h compartments, 6 doors per column
- Shipped assembled
- Beige

WL-66 12" w, 1 Column  
 WL-618 36" w, 3 Columns

## Economy Dunnage Racks

- Prolongs product life by circulating air underneath
- 12" height above floor meets all sanitary health codes
- All welded 1½" x 1½" heavy-duty, rustproof aluminum tube construction
- Lifetime guarantee against rust or corrosion on all aluminum products



	W x L	Cap.		W x L	Cap.
DASQ-3-1220	20" x 36"	2100 lb	DASQ-3-1224	24" x 36"	2100 lb
DASQ-4-1220	20" x 48"	1800 lb	DASQ-4-1224	24" x 48"	1800 lb
DASQ-5-1220	20" x 60"	1500 lb	DASQ-5-1224	24" x 60"	1500 lb

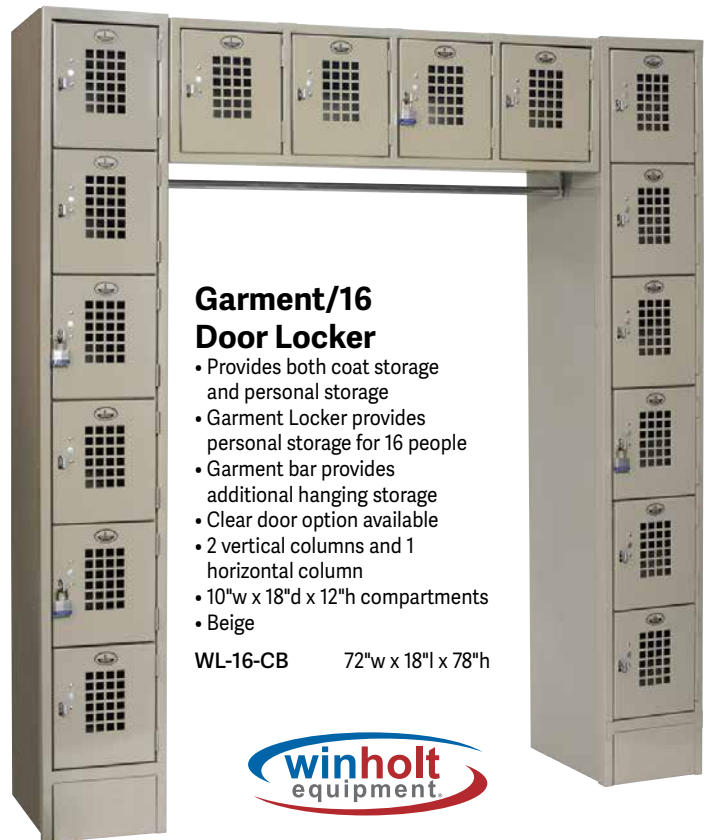

## Garment/16 Door Locker

- Provides both coat storage and personal storage
- Garment Locker provides personal storage for 16 people
- Garment bar provides additional hanging storage
- Clear door option available
- 2 vertical columns and 1 horizontal column
- 10" w x 18" d x 12" h compartments
- Beige

WL-16-CB 72" w x 18" l x 78" h



## Intelligent Locker

- 3 columns, 18 total lockers
- Powder-coated finish
- All lockers are equipped with combination locks
- Transparent window on locker doors
- Each locker has one USB outlet and one standard power socket
- Ships fully assembled
- UL certified power taps and cords
- Operates at 110V

WL-618-DGT-EL 39½" w x 16½" d x 47" h OA



## Combination Lock

- Black dial

MSLCK-1



## Camshelving® Wall Shelves

- Virtually indestructible I-beams support up to 150 lb
- Withstands temperatures up to 190°F
- Will never rust—ideal for indoor or outdoor locations
- Shelves snap on and off for easy cleaning
- Choose from slotted or solid shelves

### Solid Shelves

CSWS1436SK 36"l x 14"w x 13½"h

CSWS1448SK 48"l x 14"w x 13½"h

### Slotted Shelves

CSWS1436VK 36"l x 14"w x 13½"h

CSWS1448VK 48"l x 14"w x 13½"h

**CAMBRO**  
TRUSTED FOR GENERATIONS™



STORAGE & TRANSPORT



Smallware accessories shown are not included

## EZ-WALL™ Food Prep & Drying Station Kit

- Increases storage & workflow efficiency in prep or wash station areas
- Versatile and modular
- Includes:
  - 8 Stainless Steel Direct Wall Mounting Brackets
  - 6 Green Epoxy Coated Peg Hooks
  - 6 Stainless Steel "J" Hooks
  - 2 Green Epoxy Coated 24" x 24" Grids
  - 1 Green Epoxy Coated 13½" x 5" x 7" Basket
  - 1 Green Epoxy Coated 17½" x 7½" x 7" Basket

**FOCUS**  
FOODSERVICE  
A CROWN BRANDS COMPANY

FWMKIT1 EZ-Wall™ Food Prep and Drying Station Kit



ROY WSH 1224



## Stainless Steel Wall Shelves

- Perfect for adding storage space without using up valuable floor space
- Constructed of durable, 18 gauge stainless steel
- Mounting brackets included

ROY WSH 1224 24"l

ROY WSH 1236 36"l

ROY WSH 1248 48"l

ROY WSH 1260 60"l

ROY WSH 1272 72"l

**ROYAL**  
INDUSTRIES®  
Foodservice & Hospitality Products

**FOCUS**  
FOODSERVICE  
A CROWN BRANDS COMPANY

## Wall Mounted Utensil Rack w/ Hooks

- Stainless steel rack
- Includes 20 stainless hooks



FUR1824CHSS 18"w x 24"h

# STORAGE & TRANSPORT

## Pizza Pan Rack

- 26-tier sturdy aluminum construction
- Designed to hold and transport 17" and 19" round pizza pans and 16" and 17" square Sicilian pizza pans
- 5" full-swivel casters, 2 with brake
- 2" spacing between each tier
- 23"l x 21"w x 62<sup>7</sup>/<sub>8</sub>"h

ALPR-26BK Knocked Down  
AWPR-26BK Welded



NSF

ALPR-26BK



NSF

ALRS-20BK

## Sheet Pan Rack

- 20-tier sturdy aluminum construction
- 5" full-swivel casters, 2 with brake
- 3" spacing between each tier

Full-Size - Holds (20) 18" x 26" Sheet Pans, Side-Loading

ALRS-20BK Knocked Down, 19<sup>1</sup>/<sub>2</sub>"w x 29<sup>1</sup>/<sub>2</sub>"l x 70<sup>3</sup>/<sub>8</sub>"h  
AWRS-20BK Welded, 19<sup>1</sup>/<sub>2</sub>"w x 29<sup>1</sup>/<sub>2</sub>"l x 70<sup>3</sup>/<sub>8</sub>"h

Full-Size, Heavy-duty - Holds (20) 18" x 26" Sheet Pans  
or (40) 13" x 18" Sheet Pans

AWRK-20HBK Welded, 26"w x 21<sup>3</sup>/<sub>4</sub>"l x 70<sup>1</sup>/<sub>2</sub>"h

## Steam Pan Rack

- 36-tier stainless steel construction
- Customize with a variety of full, half and third size steam table pans and food pans for the best configuration
- Dual-ended locking bars
- 4" double-bearing, full-swivel casters
- 1<sup>1</sup>/<sub>2</sub>" spacing between each tier
- Ships knocked down

SRK-36 15<sup>1</sup>/<sub>8</sub>"w x 21<sup>5</sup>/<sub>8</sub>"l x 63<sup>3</sup>/<sub>4</sub>"h



NSF

## EC Series Enclosed Mobile Cabinets

- All welded, reinforced, non-insulated aluminum
- Double pan construction with reinforced braces, 1<sup>1</sup>/<sub>2</sub>" spacing
- Sanitary and rust-proof
- Holds (40) 18" x 26" pans
- Easily maneuverable on four 5" polyurethane, swivel plate, double ball race casters
- 21"w x 27"d x 68"h

EC1840-C Aluminum Door  
EC1840-C-LD Clear Acrylic Door



## Heavy-Duty Bun Pan Rack

- Heavy-duty aluminum frame with welded angle slides
- 3" spacing between runners
- 5" polyurethane swivel stem casters
- Holds (20) 18" x 26" sheet pans

NSF

AL-1820B-XB 21"w x 26"l x 69<sup>3</sup>/<sub>4</sub>"h



## Bakery Rack Cover

- Heavy-duty, clear plastic cover with 3 reinforced zippers
- Transparent plastic makes it easy to identify products
- Retards dehydration and enhances proofing

SRC-58-3Z 23"w x 28"l x 61"h



AL-1820B-XB



SRC-58-3Z



CR-162M



CR-54PT

Self-feeding feature  
keeps stock rotated

### Can Racks

- Organizes can stock and maximizes available space
- Vertical uprights and cross braces are constructed of 1½" aluminum tubing
- Half size racks double as a work top
- Mobile units are easily maneuvered on two 5" locking swivel and two 5" rigid polyurethane plate casters
- Lifetime warranty against rust

Full Size - Holds (162) #10 or (216) #5 Cans

CR-162 Stationary, No Top, 25¼" w x 35" l x 71" h

CR-162M Mobile, No Top, 27½" w x 35" l x 76" h

Half Size - Holds (54) #10 or (72) #5 Cans

CR-54PT Mobile, Poly Top, 27½" w x 35" l x 35" h

CR-54SS Mobile, Stainless Steel Top, 27½" w x 35" l x 35" h



AL-1810-H



AL-1810H-SSTOP

### Half Size Pan Racks

- Heavy-duty aluminum frame with welded angle slides, 3" spacing between runners
- Rolls easily on 5" polyurethane swivel stem casters
- For 18" x 26" and 14" x 18" pans and trays
- 10 pan capacity
- 21" w x 26" l x 38" h

AL-1810-H

Open Top

AL-1810H-SSTOP

Stainless Steel Top

Ready to learn more about these great products?  
**PLAY VIDEO**



AL-1820BNKD-A



ADE1820B-KDA

### Pan Racks

- Aluminum construction
- End loading
- Four swivel stem casters
- Holds (20) 18" x 26" pans



AL-1820B

Heavy-Duty, 21" w x 26" l x 69¾" h

AL-1820BNKD-A

Heavy-Duty, Nesting, Knock-Down, 21" w x 26" l x 70" h

ADE1820B-KDA

Economy, Knock-Down, 21" w x 26" l x 69" h



# WAREWASHING

## Undercounter Dishwasher

- 30 racks per hour
- Stainless steel exterior
- 2 minute cycle time
- 20" x 20" basket
- Wash and rinse temperature thermometers
- Rinse aid dispenser
- Detergent and drain pump
- Security thermostat
- Includes: 1 basket for dishes, 1 general basket, 1 cutlery container
- Gravity drain only
- 1 year parts and labor warranty
- 208-240V



DSP4DPS 23.7" w x 25" d x 32.28" h



## Undercounter Dishwasher

- 30/20/15 racks per hour
- Dishwasher w/booster, rinse, drain and soap pumps
- Stainless steel construction
- Includes: insulated control panel, 1 basket for dishes, 1 general basket and 1 cutlery container
- 4 wash cycles: 2, 3, 4 and 15 minute
- Security thermostat for automatic booster shut off
- 2 year parts and labor warranty
- 208-240V



F92EKDPS 23 3/4" w x 25 3/4" d x 33" h



3 washing cycles: 2, 3 and 4 minute

## Upright Dishwashers

- 15-30 racks per hour
- 1/2 gallon water use per cycle
- Stainless steel construction
- Linear or corner installation
- Included accessories: 2 baskets for dishes, 1 general basket, 2 cutlery containers
- Wash temperature 140°F; rinse temperature 180°F
- Security thermostat
- 23 3/4" w x 29 3/4" d x 57 1/2" h
- 1 year parts and labor warranty
- 208/240V

Shown with optional tables & accessories



L21EKS Dishwasher w/Booster, Rinse and Soap Pumps

L21EKDPS

L21EKDPS Dishwasher w/Booster, Rinse, Drain and Soap Pumps



## Undercounter Dishwasher

- 30 racks per hour with 2 minute cycle
- 20 racks per hour with 3 minute cycle
- Stainless steel exterior
- Built-in 6530 watt booster heater for 180°F final rinse water (40° to 50°F rise)
- Low 0.6 gal water usage per rack
- Removable wash and rinse arms
- 208-240V/60/1 phase
- 208-240V/60/3 phase

UC-18 23 1/2" w x 24" d x 33 1/4" h



## Hood-Type High Temperature Dishwasher

- 30 racks per hour with 2 min cycle
- Stainless steel exterior
- Built-in 9800 watt booster heater for 180°F final rinse water (40° to 50°F rise)
- Low 0.79 gal water usage per rack
- Hood operated start/stop functions
- Removable wash and rinse arms
- Straight or corner installation
- 208-240V/60/1 phase
- 208-240V/60/3 phase

D-18 28 3/8" w x 29" d x 56 7/8" h



A Division of Legacy

## Hi-Temp Undercounter Glasswasher

- 20 racks or 600 glasses per hour
- Soft Start feature lowers noise and reduces chance of glass breakage
- Heat Recovery System promotes faster drying of glasses
- Stainless steel construction
- .73 gallon of water per cycle or rack
- Safe-T-Temp booster heater for a 70°F rise
- 180°F fresh water final rinse
- Detergent and rinse aid chemical pumps
- Reduced energy costs—uses only cold water supply
- Raised door height makes it easier to remove racks
- Stainless steel upper and lower wash and rinse arms
- Automatic fill function
- 6" legs

181-VL 24"w x 27"d x 33 $\frac{3}{8}$ "h



UC50E

## High Temp Undercounter Dishwasher

- 30 racks/120 covers per hour
- Double walled stainless steel skin providing constant heating and quiet operation
- Removable wash and rinse arms allows for easy cleaning
- Fully automatic cycle for easy operation
- Built-in detergent and rinse chemical pumps
- Safety Temp feature assures 180°F sanitizing rinse every cycle
- Stainless steel safety filters protect washing pump
- Built-in 6kW booster heater
- 2.7 kW wash tank heater
- Low 0.8 US gal. water usage per rack
- Uses standard 19 $\frac{3}{4}$ " x 19 $\frac{3}{4}$ " racks
- 208-230V

UC50E 23 $\frac{7}{16}$ "w x 24"d x 33 $\frac{5}{16}$ "h



## Why the EST-FL?

The EST-FL Front Loader Dishmachines top mounted controls houses built-in chemical pumps and a deliming system that assures proper chemical usage.

<http://www.cmadishmachines.com>

## Single Rack Dishwashers

- 60 racks per hour
- High temperature sanitizing with built-in booster heater
- Uses only .96 gallons of water per cycle
- Straight-thru design
- Heavy-duty stainless steel construction
- Safe-T-Temp feature assures 180°F sanitizing rinse
- Unique spray arm system features upper and lower stainless steel wash arms with reinforced end caps
- External scrap accumulator
- Includes 1 combination rack and 1 peg rack
- 25 $\frac{1}{2}$ "w x 25"d x 60"h
- 208-220V



CMA-180C

CMA-180S  
CMA-180C

Straight Style  
Corner Style



## Front Load Dishwasher

- 90 sec cycle (40 racks per hour) standard 20" x 20" racks
- Low-temp chemical sanitizing system which requires minimum 120°F, ideal 140°F water supply
- 75% less floor space than traditional dishwashers
- Energy Star water saving design uses only 1.09 gals of water per cycle
- Powerful stainless steel pump with upper and lower wash arms
- Top mounted controls with automatic 3-product dispensing system
- Built-in scrap accumulator
- Inside sump design
- 115V



EST-FL



EST-FL 25 $\frac{1}{4}$ "w x 25 $\frac{1}{4}$ "d x 55 $\frac{1}{2}$ "- 56 $\frac{1}{2}$ "h

# WAREWASHING

## Ventless High Temperature 3-Door Single Rack Dishwasher

- 40 racks per hour (based on 90-second cycle)
- All stainless steel construction
- Replaces need for independent vent hood
- Heat recovery system
- Door-actuated start
- Safe-T-Temp feature assures 180°F sanitizing rinse
- 12kW electrical booster heater
- Low max 0.89 gallons of water usage per rack
- Maximum clearance for dishes is 17½"
- Wash tank screens filter recirculating wash water
- 3 door feature for straight or corner applications
- Field convertible from three phase to single phase
- 208/240V

CMA-180-VL 25½"w x 29"d x 85½"h



CMA-180-VL



## Conveyor Dishwasher

- 249 racks per hour
- Automatic water control system
- Uses only .49 gallons of water per rack
- Power rinse heater system
- All stainless steel construction
- Automatic soil purging system filters wash water and traps plate debris into an external tray that can be easily removed for cleaning
- Auto start/stop makes operation more energy efficient
- Includes table limit switch and rack saver clutch system that protects the machine, dish racks and table from damage
- Stainless steel chemical injection chamber
- 16 gallon wash tank, 150° to 160°F (wash), 180° to 195°F (rinse)
- Large 19" opening accommodates larger items and utensils
- 208/240/480V

EST-44 44"w x 25½"d x 55½"h, ½ hp



## Cutlery Basket

• 16¾" x 8¼" x 5⅞"  
82008 8-Compartment



82064



82050

## Dish Racks

### Glass Racks

- 19¾" x 19¾" x 4"
- 82016 16-Compartment
- 82025 25-Compartment
- 82036 36-Compartment

### Plate and Tray Racks (Peg Racks)

- 19¾" x 19¾" x 4"
- 82064 Closed Sides
- 82066 Open Sides

### Cutlery/Flat Rack

- 19¾" x 19¾" x 4"
- 82050

### Rack Extenders

- 19¾" x 19¾" x 1¾"
- 82017 16-Compartment
- 82026 25-Compartment
- 82037 36-Compartment
- 82065 Open



## Rack Dolly with Handle

82000 21¼" x 21¼" x 6¾"







## Dish Caddies

- Secure, high-capacity storage to protect both square and round plates
- Durable, polyethylene exterior will not rust, crack, dent or chip
- Poker chip style offers greater access for easy plate removal
- 3/4" plated steel rear axle allows for 500 lb load capacity
- Molded-in handles on both ends for easy transporting
- 5" front swivel casters w/brake and 10" non-marking rear wheels
- Holds 45 to 60 plates per column
- No assembly required
- Available in Black (110), Slate Blue (401), Dark Brown (131) and Speckled Gray (480)



## Adjustable Dish Caddy

- Stores one size of dish or a combination of different sizes
- 6 adjustable dividers for easy-to-adjust column towers
- Holds round plates and bowls from 4 5/8" to 13" diameter in various combinations and capacities



	Capacity Round Plates	Capacity Square Plates
<b>Versa Dish Caddies - 27"w x 30 1/2"l x 31 1/4"h</b>		
DCS950	5 Columns of 9 1/2" max	4 to 5 Columns of 8" max
DCS1125	4 Columns of 11 1/4" max	4 Columns 9 1/2" max
<b>Adjustable Dish Caddy - 28 3/8"w x 37 1/8"l x 31 3/8"h</b>		
ADCS	4 Columns of 13" max	---

WAREWASHING

## Camrack® Racks

- Camracks get your dishes clean, keep them clean, and transport them with unique closed wall rack, Camdolly and cover
- Easy-to-grip handles are designed for comfortable, safe handling and lifting
- Full size racks are 19 3/4" x 19 3/4"
- Stacks with all major racks and integrates with all operations to reduce waste or confusion
- No rust because design uses no screws, rivets, or bolts
- Available Colors: Black (110), Sherwood Green (119), Soft Gray (151), Red (163), Brown (167), Blue (168), Beige (184), Navy Blue (186), Teal (414), and Cranberry (416) (Extender, Flatware Rack and Flatware Baskets are available in Soft Gray only)



## Adjustable Dish Caddy Configurations

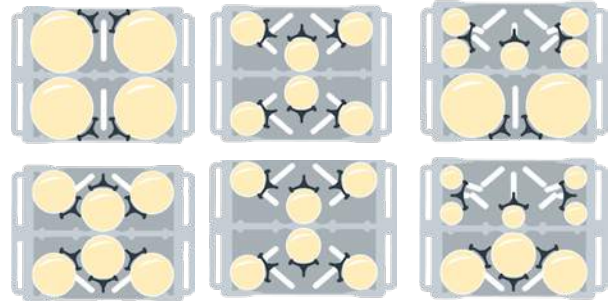

### Base Rack

BR258 1 Compartment, 3 1/4"h

### Glass Racks

		Maximum Dia x Height
20S638	20-Compartment	3 3/8" x 6 1/8"
20S800	20-Compartment	3 3/8" x 8 1/2"
25S318	25-Compartment	3 7/8" x 3 3/8"
25S434	25-Compartment	3 7/8" x 5 1/4"
25S534	25-Compartment	3 7/8" x 6 1/8"
25S638	25-Compartment	3 7/8" x 6 7/8"
25S738	25-Compartment	3 7/8" x 7 1/4"
25S800	25-Compartment	3 7/8" x 8 1/2"
30S638	30-Compartment	3 1/8" x 6 7/8"
30S800	30-Compartment	3 1/8" x 8 1/2"



### IceExpress Water Glass Filler

- Fills 25 glasses with ice simultaneously, rather than one at a time
- Made of lightweight, durable, FDA approved ABS plastic
- Color: Black (110)

### IceExpress Water Glass Filler

25SWG 25-Compartment

### Flatware Rack

FR258 Full Size, 4"h

### Flatware Basket w/Handles

8FB434 Half Size, 8-Compartment, 7 1/4"h

### Peg Racks

PR314 9" x 9" x 3 1/4"

PR59314 5" x 9" x 3 1/4"

### Camdolly® & Rack Cover

CDR2020 Dolly, 350 lb Capacity

DRC2020 Cover, Full Size

### Camrack Cover & Camdolly®

- Camrack Cover and Camdolly create a portable sanitary storage system that protects contents and eliminates the use of messy, wasteful plastic wrap or vinyl covers
- Color: Camdolly is Soft Gray (151), Rack Cover is Gray (180)



# WAREWASHING

Ready to learn more about these great products?

**PLAY VIDEO**



## Cutlery Polisher

- Turns wet, clean cutlery into dry, spot-free, sparkling cutlery
- Reduces labor costs, risk of injury and unhygienic handling associated with hand polishing



CP-7000 Polishes up to 4,000 Pieces/hr

## FLY-BYE™ Floor Drain Trap Seals

- Installs quickly and easily in minutes
- Makes drains virtually maintenance free
- One-way silicone valve stops fruit flies and cockroaches from entering up through the drain
- Keeps bacteria, nasty smells and gases in the drain
- Stops the need for adding primers and fresh water
- Does not impede flow rate
- Pesticide-free



Drain Size

FB-TS20	2"
FB-TS30	3"
FB-TS35	3½"
FB-TS40	4"

Ready to learn more about these great products?

**PLAY VIDEO**



# TAYLOR

## Digital Dishwasher Temperature Plate

- Ensures proper washing and rinse temperatures in the dishwasher
- Measures surface temperature of water
- Accuracy ±1.8°F
- FDA Food Code compliant for sanitation
- IP67 rated and NIST-Traceable Certificate included



8791 32° to 194°F

# TAYLOR

## Dishwasher Test Labels

- Strips can be applied to dry item and placed in the dishwasher
- Color changes to verify proper sanitation
- Strip can be removed, signed and dated
- Accuracy ±2°F



Labels/Pk

8750	180°F/82°C	24
8751	160°F/82°C	24
8752	170°F/82°C	24
8769	160°F/72°C, 170°F/77°C, 180°F/82°C	27

8751



Ready to learn more about these great products?

**PLAY VIDEO**



## Wall Mount Pre-Rinse

- Spring type with chrome hose cover
- Hose grip reduces heat transfer to hands
- 3-ply nylon reinforced hose
- Spray head hook holds head away from work area when not in use

WS-SPR-ST-WH

Polished chrome plated brass



## Three Tub Sink Hardware Kit

- Includes 1 wall mount pre-rinse WS-SPR-ST-WH, (1) 14" add-on swing faucet WS-SFSM-14ST-LF-WH, and 3 rotary lever waste valves WS-RLWV-ST-WH

WS-3TKT-STD-WH

Ready to learn more about these great products?

**PLAY VIDEO**



## E-Z Install Flexible Water Line Kits

- For wall-mount faucets
- (2) ¾" stainless steel braided flexible supply hoses
- Includes ½" NPT close elbows with swivel compression fittings on faucet side & ¾" swivel compression fittings on water supply side
- No soldering or teflon tape required
- Temperature range 40° to 180°F



21-443L 22" long

21-445L 30" long

## Wall Mount Hand Sinks

- 304 stainless steel
- Lead free faucet & drain included



Space Saver - 12¾" w x 15¾" d x 13" h

81400<sup>^</sup> Sink

81401<sup>^</sup> Sink with Side Splashes

<sup>^</sup>NSF

Standard - 17" w x 15¼" d x 8½" h

81500 Sink

81501 Sink with Side Splashes

### Wrist Blade Handles

81520 Chrome Plated, 1 Hot (Red) & 1 Cold (Blue)



## Space Saver Hand Sinks

- 20 gauge 304 stainless steel
- 4" splash-mounted gooseneck faucet
- Color-coded hot and cold indicators
- Wall bracket included
- Low lead faucets, less than 0.25%

ROY HSW 12 9" x 9" x 5" Bowl

ROY HSW 15 10" x 12¾" x 6" Bowl

### w/Side Splashes

ROY HSSH 12 SP 9" x 9" x 5" Bowl

ROY HSSH 15 SP 10" x 12¾" x 6" Bowl



ROY HSW 12



ROY HSSH 12 SP

## Wall Mount Hand Sinks

- Stainless steel
- Deep drawn bowl to prevent spillage
- Wall mount faucet
- Wall bracket & drain included
- Lead free compliant
- High quality ¼ turn ceramic cartridge valves

HS-2L 16" w x 15" d

HS-9L 12" w x 16" d

HS-7 16" w x 15" d, w/Soap and Towel Dispenser

### w/Side Splashes

HS-26L 16" w x 15" d

HS-30L 12" w x 17" d



HS-26L



## Mobile Hand Sink

- 300 series stainless steel construction
- Faucet blends hot and cold water
- 6" boxed backsplash with stainless steel paper towel holder
- 10" x 14" x 6" deep tub with 3½" basket drain and 13 oz soap dispenser
- 5 gal clean water storage and 6 gal waste water storage
- 110°F water supplied at 0.32 GPM
- UL listed Stiebel Eltron Mini water heater at 120V/15A
- UL listed Shurflo water pump at 115V
- 5" swivel polyurethane casters with brakes
- Lifetime warranty against corrosion



STCT-BHD2436PUMP 26½" w x 24" d x 44" h



# WAREWASHING



## Heavy-Duty Wall Mount Pre-Rinse

- Built for high volume use
- High quality ¼ turn ceramic cartridge valves
- Heavy-duty spring on top for increased movement
- Built-in internal check valves
- 1.2 gpm spray valve
- 8" center

17-108WL



## Heavy-Duty Wall Mount Pre-Rinse

- Built for high volume use
- High quality ¼ turn ceramic cartridge valves
- Heavy-duty spring on top for increased movement
- Built-in internal check valves
- 1.2 gpm spray valve
- 1¼" single hole

17-202WL



## Heavy-Duty Wall Mount Pre-Rinse w/Add-On Faucet

- Same great features as 17-108WL plus includes a swing faucet

17-109WL



## Replacement Spray Valve

- Low flow
- Energy saver uses only 1.20 gpm @ 60 psi
- Fits most brands

21-129L



## Service Faucet

- 8" centers
- High quality faucet built for durability
- High quality cartridge valves
- Full replacement parts available
- 6½" heavy cast spout with pail hook and hose thread

16-127



## Commercial Series Wall Mount Faucets

- 8" centers
- Full replacement parts available

12-808L 8" Spout  
12-812L 12" Spout  
12-814L 14" Spout

## Heavy-Duty Wall Mount Faucets

- 8" centers
- High quality faucet built for durability
- High quality ¼ turn ceramic cartridge valves
- Full replacement parts available

14-808L 8" Spout  
14-812L 12" Spout  
14-814L 14" Spout



## Add-On Faucet

- Add to pre-rinse faucets
- 12" swing spout
- Shut-off valve located in front for easy access
- Full replacement parts available

21-139L



## Replacement Pre-Rinse Hose

- Heavy-duty hose fits all manufacturer's pre-rinse units
- Heat resistant handle
- 44" long

21-133L

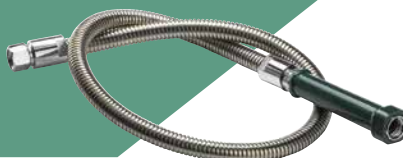

## 4" Center Wall Mount Faucets

- Heavy-duty spout with double O-Ring construction and welded shoulder for durability
- High precision machining and polished nickel chromium finish
- Color-coded handles
- Mounting kit included
- 2 GPM max

10-400L 3½" Gooseneck Spout  
10-435L 4" Double Bend Spout



10-435L



### Pre-Rinse Units

- Water saving ultra spray valves
- Adjustable wall brackets
- EZ Install Adapters



• 8" C/C backsplash control valve  
64793



• 8" C/C backsplash control valve  
• Add-on faucet 12" spout  
48917



• Single deck dual control valve  
• Add-on faucet 12" spout  
34193

### Ultra Spray Plus

- Lowest energy user – 1.15 GPM @ 60 PSI
- WaterSense Certified
- EPA Act 2005 compliant
- Interchangeable with all brands
- Guaranteed 1 million cycles



2949

### Double Knee Valve

- Polished chrome

3174



### Pre-Rinse Replacement Hose

- 3-ply aircraft hydraulic hose
- 44" long with handle
- Interchangeable with all brands

2918



### Deck Mount Faucets



3313 12" Swing Spout, 8" Deck Control Valve



3010 6" Swing Spout, Single Deck Control Valve



### Specialty Faucets

- 4750 10" Swing Spout, Chinese Range Control Valve
- 4730 18" DJ Spout With Control Knob, Single Control Valve
- 8253 8" Adj. Wall Control Valve, Long Spout/Wall Bracket, Vacuum Breaker



4750



4730

### Chem-Tee Adapter

- Pipe-to-hose adapter tee
- Stainless steel
- 40° to 140°F temperature/200 psi pressure limits
- Includes flush mount 3/8" NPT plug

72813 3 7/8" long



90476

### Backsplash Mount Faucets

- 90476 6" Swing Gooseneck, 4" C/C Backsplash, Control Valve, Wrist Handles
- 3613 12" Swing Spout, 4" C/C Backsplash, Control Valve
- 64769 12" Swing Spout, 8" C/C Backsplash, EZ Install Adapters
- 5414 14" Swing Spout, 8" C/C Backsplash, Control Valve, 3/4" Faucet



1400

### Glass Fillers

- 1400 10" Pedestal, w/12" Sink Assembly
- 1007 8" Pedestal, Filler Only



### DrainKing™

- 22209 Flat Strainer
- 22306 Flat Strainer w/Over Flow

### Combination Dipperwell Faucet

- Dipperwell faucet
- Sink
- 1 1/2" x 4" tailpiece



3041

# JANITORIAL

## Stera-Sheen Cleaner

- Cleans and sanitizes anything; recommended for: ice cream, frozen drink and dessert machines, ice tea dispensers & brewers, soda and beer lines, ice machines, floors, walls and grout
- No need for separate procedures to clean, delime and remove milkstone from your machine and parts

32-1805 Green 4 lb Jar, 4 per case  
 32-1802 Green 2 oz Packet, 100 per case



## Lubricants

- For use on slicers, can openers, cutters, mixers, band saws, grinders and other food contact equipment
- Odorless, tasteless & non-toxic



85-1152

32-1683 Petro-Gel Food Grade Grease, 4 oz Tube  
 85-1134 High Temp Grease, 14 oz Cartridge  
 85-1111 Lubri-Film Food Grade Grease, 4 oz Tube  
 85-1114 Gas Valve Grease, 2 1/2 oz Tube  
 85-1110 Food Machine Oil, 16 oz Bottle  
 85-1152 Light Duty Spray; Lubricant, 9 oz Can



## Stainless Steel Polish

- Removes greasy films, water marks and fingerprints
- Repels water

32-1702 Gallon Can



## Stera-Sheen Fryer & Filter Cleaner

- Non-caustic formula safely cleans in one easy operation
- Strong alkali ingredients dissolve oil and grease quickly
- Recommended for cleaning fryers, popcorn kettles and vent hood filters

32-1800 6 oz Packets, 24/Case



## High Heat Spray Paint

- Withstands temperatures to 600°F for long periods and 1000°F for intermittent periods
- Dries in approximately 10 minutes
- Use on boilers, furnaces, radiators, heaters, gas grills, ranges and ovens
- Must ship ground only
- 12 oz can, 12 per case

85-1105 Black Color



## Loctite 567 Thread Sealant

- Provides an instant seal
- .20 fl oz tube

32-1674



## Spray Alert™ System

- Includes 3 Spray Alert™ bottles and 3 Smazer® general purpose trigger sprayers in a clear poly bag
- Bilingual in English/Spanish
- Product check-off identification
- Embossed graduation scales
- Dilution ratios
- Key safety information, references MSDS, eye and hand protection

5024SS 24 oz  
 5032SS 32 oz



## Plastic Bottles & Trigger Sprayers

- Made of recyclable HDPE
- Dilution ratios and integrated graduation embossments
- Enhanced "spray-grip" texture
- FDA compliant material
- General purpose trigger sprayers feature an adjustable nozzle

5024WG Bottle, 24 oz  
 5032WG Bottle, 32 oz  
 58062491 Sprayer, 8 1/8" Tube  
 59062491 Sprayer, 9 7/8" Tube



5032WG

59062491





## Mop Heads

- Poly cotton blend
- 4-ply yarn
- 1¼" narrow band

### Blue Yarn

MOP-24	24 oz, Looped End
MOP-24C	24 oz, Cut End
MOP-32	32 oz, Looped End
MOP-32C	32 oz, Cut End

### White Yarn

MOP-24W	24 oz, Looped End
MOP-24WC	24 oz, Cut End
MOP-32W	32 oz, Looped End
MOP-32WC	32 oz, Cut End



## Wire Trash Can Cart

- Fits slim waste cans
- Capacity up to 400 lbs
- Wheels measure 3¾" dia
- 18½"l x 9½"w x 7"h



DWR-1708

## Cigarette Receptacles

- Receptacles will not rust, dent or crack
- Made of flame retardant, sturdy polyethylene
- Galvanized steel liner and urn utilize Cease Fire to automatically extinguish cigarette butts
- Galvanized steel pail
- ADA compliant

ASH 26800B	Beige
ASH 26800D	Black



## Kleen-Pail® Pro

- Molded in handles
- Dishwasher safe
- Available in Red (RD) for sanitary solutions and Green (GN) for cleaning solutions



KPP97	3 qt
KPP196	6 qt
KPP256	8 qt



Patented, curved shape for easy pouring

## KatchAll® Flatware Retriever

- Magnetic bar keeps flatware from falling into the trash
- Large opening allows easy passage of waste into the receptacle
- Fits a variety of waste receptacles
- Dishwasher safe



	Fits	Color	Dia x H
KA3244	32 & 44 gal	Red	24" x 9"
KA3200	32 gal	Red	22¼" x 10½"
KA4400	44 gal	Burgundy	24¾" x 8½"



## Brute® Round Containers, Lids, & Dolly

- All-plastic, professional grade construction will not rust, chip or peel
- Built-in handles allow for easy, non-slip lifting and anti-jam nesting
- Double-ribbed base increases stability and dragging capacity
- Reinforced rims add strength and durability
- Venting channels create airflow throughout the container, reducing the pull force to lift out liners by up to 50%
- Self-draining lids have channels to prevent water from pooling

### Containers

- FG261000 10 Gallon, (GRAY), (WHT)
- FG262000 20 Gallon, (GRAY), (WHT), (YEL), (BLUE)
- FG263200 32 Gallon, (GRAY), (WHT), (YEL)
- FG264360 44 Gallon, (GRAY), (YEL)
- 1779740 44 Gallon, (WHT)
- FG265500 55 Gallon, (GRAY), (YEL)



### Recycling

- FG263273 32 Gallon, (BLUE)
- FG264307 44 Gallon, (BLUE)

### Lids

- FG260900 Fits 10 Gallon, (GRAY), (WHT)
- FG261960 Fits 20 Gallon, (GRAY), (WHT), (YEL)
- FG263100 Fits 32 Gallon, (GRAY), (WHT), (YEL)
- FG264560 Fits 44 Gallon, (GRAY), (WHT)

### Dolly

- FG264000 Fits 20, 32, 44, & 55 Gal, (BLA)



Ready to learn more about these great products?  
**PLAY VIDEO**

## Slim Jim® Vented Containers, Lid & Dollies

- Venting channels take the strain out of liner removal
- Space-saving profile fits virtually anywhere
- Four can liner clinches improve productivity
- Molded-in handles and base grips make lifting and emptying easier
- 23 gallon

### Containers

- FG354060 (GRAY), (BLK), (BEIG)
- FG354007 Recycling, (BLUE), (GRN)

### Dollies, Stainless Steel

- 1968468 Single Dolly
- 1956191 Double Dolly

### Swing Lid

- FG267360 (GRAY), (BLK), (BEIG)



## Slim Jim® Undercounter Containers

- Commercial-grade construction
- Angle opening eliminates the need to pull out container from under the counter
- Integrated venting channels and bag cinches
- Space efficient design
- Made in USA

	Color	Capacity
2026695	Gray	13 gal
2026696	Black	13 gal
2026697	Brown	13 gal
2026698	Beige	13 gal
2026699	Blue	13 gal
2026700	Green	13 gal
2026721	Gray	23 gal
2026722	Black	23 gal
2026723	Brown	23 gal
2026724	Beige	23 gal
2026725	Blue	23 gal
2026726	Green	23 gal





## Value-Plus™ Slim Containers

- Perfect for small spaces where you need a receptacle
- Easy grip bottom
- 23 gal, 10¾" w x 21" l x 30" h

STC2303	Gray
STC2310	Black
STC2304RL	Recycle, Blue
STC2307RL	Recycle, Green



**Impact**  
Everything.

## Value-Plus™ Trash Containers

- Rugged, one-piece molded construction with sturdy handles
- Ideal for a variety of applications
- Made in the USA

32 Gallon	
GC320101	White
GC320103	Gray

44 Gallon	
GC440101	White
GC440103	Gray



## Gator® Dolly

- Fits 20, 32 and 44 gal trash containers
- (5) 3" swivel casters
- 17½" dia

7704      Gray



**Stops outside drafts, flying insects and airborne pollutants**

## Air-Pro® Series Air Curtains

- For interior mounting only with door heights up to 8'
- Reduces energy costs substantially
- Re-circulates warm air inside the building
- Housing, grill and nozzle are 300 grade stainless steel
- Built-in high/low switch for 2 speed motor
- 1 year warranty on parts
- 120V

**Cutron** Products  
A SENNECA COMPANY



AP-2      (1) ½ hp Motor for 36" to 60" Doors  
AP-4      (2) ½ hp Motors for 72" Doors

## Hand Dryers

- White porcelain enamel exterior
- Surface mounted
- 12¾" l x 8¾" w x 7" h
- 120V, 2200W



ROY DRY 2200ES



ROY DRY 2200ES      Push Button  
ROY DRY 2200EA      Automatic

ROY DRY 2200EA

## High Speed Automatic Hand Dryers

- Infrared automatic detection
- Motor overload protection
- Replaceable fuse
- High-speed drying 10-15 seconds
- 110V, 1600W



ROY DRY JA01

ROY DRY JA05



ROY DRY JA01  
ROY DRY JA05

Steel Case with White Porcelain Enamelled Coating  
Stainless Steel with Polished Finish

**ROYAL INDUSTRIES**  
Foodservice & Hospitality Products

# JANITORIAL

## Integra™ Level Roll Towel Dispenser

- No wasted space—compact dispensing arm is virtually the same size as an 800' roll
- Integrated dispensing arm is easy to operate with your arm, wrist or elbow
- Dispenses all paper qualities with any size core, including coreless, solid or unperforated centerpull
- Black Pearl
- 11½" w x 11¼" d x 13½" h



T850TBK Holds (1) 8¼" wide Roll



## Simplicity Essence™ Hands Free Classic Paper Towel Dispenser

- Lower pull force offers hands-free dispensing of many types of roll towel
- Fast paper delivery—no need to wait for a sensor
- Automatic precision mechanical cutting dispenses 10" portions of roll towel
- Black Pearl
- 12¾" w x 9½" d x 14½" h



T7400TBK Holds (1) 8" wide Roll

## Tear-N-Dry™ Essence Classic Paper Towel Dispenser

- Touchless towel dispenser
- Consistently dispenses 10" of paper without a wait
- Uses 4 D-cell batteries
- Impact resistant plastic construction
- 11¾" w x 9½" d x 147/16" h
- Black Pearl



T8000TBK Holds 8" wide Roll

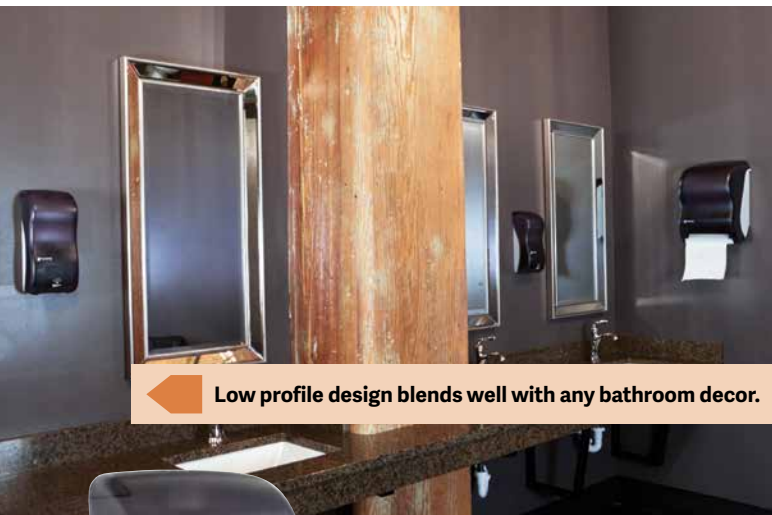

Low profile design blends well with any bathroom decor.

## Classic® Duett Bath Tissue Dispenser

- Break-resistant plastic
- Accepts standard/industrial bath tissue
- Continual availability of paper provided by the Infinity System®, eliminating stub roll waste
- Compact design
- Full swing replaceable cover & lock
- Black Pearl
- 7½" w x 7" d x 12¾" h



R3500TBK Holds (2) 4½" to 5½" Rolls

## Twin Jumbo Bath Tissue Dispenser

- Dispenses any brand or quality of 9" jumbo bath tissue
- Infinity® system eliminates stub roll waste
- Impact resistant plastic construction
- Black Pearl



R4000TBK Holds (2) 9" Jumbo Rolls



## Rely™ Hybrid Soap Dispenser

- Touchless electronic soap dispensing
- Push cover allows for manual dispensing when batteries are low
- Easy maintenance
- Black Pearl
- 5½" w x 4" d x 12" h



SH900TBK 900 ml Capacity



38-1517



38-1207



38-1035



38-1135



38-1003



38-1038



38-1558

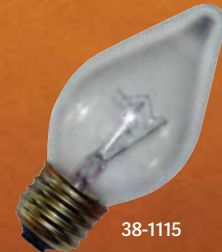

38-1115

### Long Appliance Bulbs

• 40W

- 38-1517 PTFE Coated, 130V
- 38-1207 Silicone Coated, 130V



### Incandescent Lamps

- 38-1003 Clear Oven Lamp; 120V, 50W
- 38-1038 Appliance Lamp, Frosted White Coating Inside Bulb; 130V, 40W
- 38-1067 Rough Service - Safe Shield, Not for Oven Use, Silicone Coating; 130V, 100W

### Infrared Heat Lamps

• 250W

- 38-1035 Clear, 120V
- 38-1135 Clear PTFE Coated, 125V

### Shatterproof PTFE Coated Light Bulbs

• 500°F

- 38-1558 Appliance Lamp; 130V, 40W
  - 38-1513\* Bulb; 130V, 40W
  - 38-1116 Lamp; 130V, 40W
  - 38-1115 Lamp, Teardrop Style; 120V, 60W
  - 38-1481 Bulb; 130V, 100W
  - 38-1554 Bulb, Teardrop Style; 230/240V, 50/60W
  - 38-1206 PTFE Coated Lamp; 230V, 40W
- \*Silicone coated, suitable for refrigeration



### Clear Vu® Soap Dispensers

- Works with antimicrobial, antibacterial and antiseptic soaps
- Dispenses approximately 1 cc per stroke
- Unique water-resistant top
- Large push bar meets ADA requirements

#### Lotion Soap Dispensers

- 9330 30 oz, 4 1/2" w x 6 1/4" l x 4" h, White
- 9331 30 oz, 4 1/2" w x 6 1/4" l x 4" h, Gray
- 9346 46 oz, 5 1/2" w x 8 1/2" l x 4 1/4" h, White
- 9347 46 oz, 5 1/2" w x 8 1/2" l x 4 1/4" h, Gray

#### Foam Soap Dispensers

- 9335 30 oz, 4 1/2" w x 6 1/4" l x 4" h, White
- 9336 30 oz, 4 1/2" w x 6 1/4" l x 4" h, Gray
- 9344 46 oz, 5 1/2" w x 8 1/2" l x 4 1/2" h, White
- 9345 46 oz, 5 1/2" w x 8 1/2" l x 4 1/2" h, Gray





PBJC-303084-X

## Janitor Cabinets with Mop Sink

- Stainless steel with satin finish
- 2 lockable swing doors
- Includes heavy-duty service faucet and 10' service faucet hose
- Deluxe models feature a 3-shelf storage cabinet with bottom storage area

25"w x 22"d x 84"h

PBJC-252284-2D-X      20" x 16" x 12" Sink

30½"w x 30½"d x 83½"h

PBJC-303084-X      24" x 24" x 12" Sink

DELUXE, 21⅜"w x 48"d x 84"h

PBJC-4884-L-X      20" x 16" x 12" Left-Side Sink

PBJC-4884-R-X      20" x 16" x 12" Right-Side Sink



## Mat Washing Cabinet

- Stainless steel with satin finish
- 2 vented, swing panel doors with lock handle
- Oversized sink: 38" x 20" x 6"d with drain
- Service faucet and 10' hose

PBMC-432683-X

43"w x 26"d x 83"h



Fold-Down  
Chemical Shelf



Side Mounted  
Mop/Broom Holder

## Floor Troughs

- 14-gauge, type 300 stainless steel
- Subway-style grating
- Available with stainless steel or fiberglass grating
- Accommodates up to a 4" diameter pipe
- Includes stainless steel removable perforated strainer

### With Stainless Steel Grates

FTSG-1224-X	12" x 24"
FTSG-1236-X	12" x 36"
FTSG-1248-X	12" x 48"
FTSG-1260-X	12" x 60"
FTSG-1824-X	18" x 24"
FTSG-1836-X	18" x 36"
FTSG-1848-X	18" x 48"
FTSG-1860-X	18" x 60"

### With Fiberglass Grates

FTFG-1224-X	12" x 24"
FTFG-1236-X	12" x 36"
FTFG-1248-X	12" x 48"
FTFG-1260-X	12" x 60"
FTFG-1824-X	18" x 24"
FTFG-1836-X	18" x 36"
FTFG-1848-X	18" x 48"
FTFG-1860-X	18" x 60"



Stainless Steel Grates



Fiberglass Grates

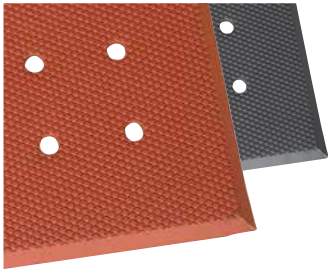

### VIP Cloud Floor Mats

- Molded non-absorbent closed-cell foam rubber
- Grease proof nitrile with antimicrobial additive to prevent mold, mildew and bacterial growth
- Tapered on all sides for safety
- Anti-slip textured surface
- Avoid using in very wet areas
- 5 year guarantee against breakdown from grease
- 3/4" thick, size: 3' x 5'



**Cactus Mat**  
MANUFACTURING COMPANY  
*Quality and Integrity since 1930*

5000-R35 Grease Proof Red  
2200-35H Grease Proof Black

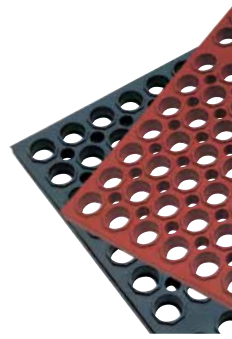

### VIP Deluxe Heavy-Duty Mats

- Ideal for restaurant, bar, industrial and commercial use
- Anti-fatigue - eases the strain of standing and improves worker productivity
- Anti-slip, raised surface provides safe footing
- Custom cutting - may be cut to fit any area
- Large holes and raised underside knobs improve drainage
- 7/8" thick
- Available in sizes: 29" x 39" or 58 1/2" x 39"

2520BLACK General Purpose Black  
2520RED Grease Proof Red

### VIP TopDek Junior Mats

- Molded, beveled edge on all sides for easy cart access
- Anti-slip surface for a safer work area
- Anti-fatigue for worker comfort and improved productivity
- Excellent drainage
- Size: 3' x 5'
- Approximately 1/2" thick

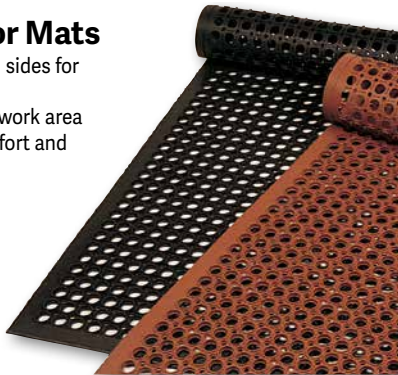

2530C5 General Purpose Black  
2530R5 Grease Resistant Red

### VIP Prima Rubber Mats

- Ideal for bars, service areas, any non-grease kitchen and industrial area
- Anti-fatigue
- Anti-slip, raised surface provides safe footing
- Light weight for easy handling
- Snaps together to easily accommodate any area with built-in connectors
- 1/2" thick
- 3' x 3'

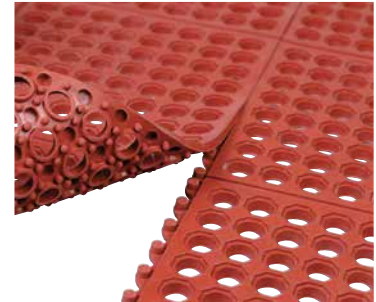

2523-C BLACK General Purpose Black  
2523-R RED Grease Resistant Red

### Catalina Olefin Carpet Mat

- Works in all kinds of weather, protecting floors from dirt, moisture and wear
- Long-wearing 100% continuous filament olefin pile accepts heavy traffic without fuzzing or pilling
- Solution dyed fibers are long wearing and will not fade or discolor in sunlight
- Traps 1.2 gallons of water per square yard
- Approximately 5/8" thick
- Colors: Castellan Red, Green, Charcoal, Pebble Brown, Marlin Blue and Chocolate



1437 Many Sizes Available

### VIP TuffDek Floor Mats

- Excellent comfort underfoot in a variety of kitchen and commercial applications
- Lighter weight, easier to handle
- Anti-slip aggressive surface design provides security underfoot
- Anti-fatigue eases the strain of standing and improves worker productivity
- Excellent drainage of liquids and waste
- 7/8" thick, size: 3' x 5'

3525BLACK General Purpose Black  
3525RED Grease Resistant Red



### Ridge-Scraper Heavy-Duty Rubber Safety Mats

- Indoor and outdoor use
- Cleated backing helps prevent movement
- Reduces slips and falls
- Tapered edge on all 4 sides
- 3/8" thick
- Black

1625-35 3' x 5'  
1625-46 4' x 6'  
1625-31 3' x 10'



**Cactus Mat**  
MANUFACTURING COMPANY  
*Quality and Integrity since 1930*



### Hot Water Hose

- 200°F hot water rating
- 400 lb burst rating
- Red

724311 50' long x 5/8" dia

### Hot Water Nozzle

- Contoured grip
- Insulated
- Positive shut off
- Fine mist to full stream
- Red

572-NOZ

# JANITORIAL

## Easy Motion Floor Machine

- Dry cleans carpet and removes allergens
- Buffs and sands hard wood floors
- Scrubs and cleans ceramic tile, grout, brick and concrete
- Polishes and strips vinyl
- Cleans, polishes and protects marble
- ½ hp
- 30' cord

BGEM9000 12" Pad, 13" Cleaning Path



## Floor Dryer/Air Mover

- Sealed 3-speed, ½ hp motor
- 9½" dia blower fan
- Stackable
- 4 position height adjustment with kickstand
- Heavy-duty yellow polyethylene housing
- 25' cord
- 115V

AM10D



## BigGreen Commercial™ Sweepers

- Works great for low pile carpets and bare floors
- Corner brushes and floating heads for more flexibility
- Durable, threaded handles and quiet motor-free systems
- Soft rubber wheels conform to a variety of floor surfaces
- 7½" w cleaning path
- Limited 1-year commercial warranty

BG21 Dual Rubber Brushes for Wet Messes



**Bissell®**  
BigGreen Commercial™

## Cord-Free Electric Sweeper

- Virtually indestructible high impact housing and hood
- Titanium bushings for brush roller
- Telescoping handle
- Nickel-Metal-Hydrate battery lasts 90 minutes
- Weighs only 3.9 lb

BG9100NM Battery Operated Sweeper

## Lightweight Portable Canister Vacuum

- Ultra quiet low noise technology
- Uses 20% less energy with 30% more power
- 110" of waterlift—the most suction of any commercial vacuum of this size
- Ametek Advantek powered motor
- 8-piece tool kit - combo rug & floor tool with swivel neck & rear wheels, upholstery tool w/slide-on brush, round brush, floor tool, crevice tool & metal telescopic wand
- E-Z push-in / pull-out commercial grade hose - no clips to break
- Non-marking rubber coated rear wheels
- Limited 2 year warranty

BGC3000



## BigGreen Commercial™ Lightweight Upright Vacuum

- 13" wide cleaning head
- Weighs only 8 pounds
- Virtually indestructible reinforced fan has a lifetime warranty
- Self adjusting, goes from carpet to bare floors with no adjustments
- 40 ft power cord
- Powerful, high-speed, balanced roller brushes
- 2 year commercial warranty

BGU8000EW



## ProCup Commercial Vacuum

- Lightweight with carry handle
- Includes a crevice tool, combination dusting brush/upholstery tool & extension wand
- Attachments store in back of vacuum
- 5-position height adjustment
- 3 stage filtration
- 30' cord
- 1 year warranty

BGU1937T 13½" Cleaning Path

**Bissell®**  
BigGreen Commercial™





SPD-20-AL

### Service-Pro® Swinging Doors

- Satin anodized finish
- 9" x 14" window
- Lightweight and easy to open
- A variety of sizes available



SPD-20-AL Light Duty, .063" Tempered Aluminum  
 SPD-30-AL Medium Duty, .032" Tempered Aluminum Wood Core

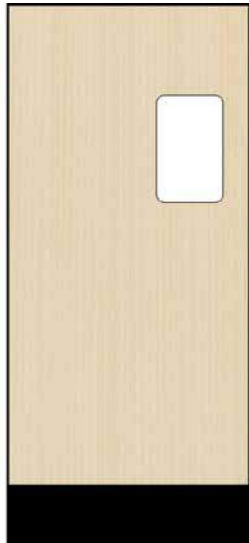

### Restaurant Door

- 8" high black scuff plate
- Neatly hidden hardware (patent pending)
- 1½" thick polymer core
- Standard flush 9" x 14" clear acrylic, double glazed window

ENG-1 36" x 84" (Single Opening)  
 ENG-1 48" x 84" (Paired, Includes 2 each 24" wide Panels)



### SC 3000 Series Traffic Door

- Solid core door is durable with aesthetic appeal
- Constructed with a ¾" cabinet grade birch plywood
- Variety of finishes available: stainless steel, aluminum and laminate
- Standard 18 gauge stainless steel edge capping presents a clean, finished appearance and extra edge protection
- Factory installed 9" x 14" polycarbonate window
- A variety of options can be added to meet your exact requirements
- Made in the USA

SCP 3 Wood Core with Stainless Steel



## Ladderback Metal Chairs & Barstools

- Durable metal frames with matte black finish
- Available with wood or upholstered vinyl seats
- Wood seats available in Natural (N) or Walnut (W) finish
- ROY 9001 and ROY 9002 upholstered seats available in Black (BLK), Red (RED), Brown (BRN) or Crimson (CRM) – add suffix to item number to specify



ROY 9001BLK



ROY 9002W



ROY 9002N



## Wood Ladderback Chairs & Barstools

- Available with wood or upholstered seats
- Hardwood ladder back frames
- Natural (N) or Walnut (W)
- Upholstered seats available – add color behind item number (RED, CRM, BLK, BRN)

### Chairs - 33½"h

ROY 8001W Walnut Finish  
 ROY 8001N Natural Finish

### Barstools - 43½"h

ROY 8002W Walnut Finish  
 ROY 8002N Natural Finish



ROY 8001WRED



ROY 8001W



ROY 8002NBLK



FURNITURE

## Circular Chrome Frame Barstools

- Tee-nut construction
- Chrome frame with single or double ring
- Ball bearing swivel
- Heavy-duty plastic glides

Upholstery Colors: B=Black, R=Red, CRM=Crimson and BRN=Brown

- ROY 7710\* Classic 1950's Chrome Band, Double Ring
- ROY 7711 Standard Seat, Single Ring
- ROY 7712 Standard Seat, Double Ring
- ROY 7715 Standard Seat with Back, Single Ring
- ROY 7716 Standard Seat with Back, Double Ring
- ROY 7721 Bucket Seat, Single Ring
- ROY 7722 Bucket Seat, Double Ring

\*Available in Black only

### Standard Seats

- 4" thick tailored seat with two sewn welts
- Heavy-duty fabric back vinyl upholstery
- Models also available with back

### Bucket Seats

- High back for added comfort
- Heavy foam padded waterfall seat
- Heavy-duty fabric back vinyl upholstery



ROY 7710B



ROY 7711B



ROY 7715B



ROY 7716B



ROY 7721CRM



ROY 7722BRN



ROY 7712R



ROY 7723R



## Bistro Chair

- Heavy-duty welded steel frame
- Powder coated Black frame
- Fabric back vinyl upholstery
- Available in Red and Black

ROY 717 Bistro Chair



ROY 717R

## Square Frame Barstools

- Tee-nut construction
- Black frame with single ring
- Ball bearing swivel
- Chrome glides with nylon base

Upholstery Colors: B=Black, R=Red, CRM=Crimson and BRN=Brown

- ROY 7714 Bucket Seat
- ROY 7723 Standard Seat



ROY 7714CRM

## Stacking Chair

- 18 gauge steel frame
- Double powder coated black finish
- Heavy-duty fabric backed vinyl
- Additional triple bar support
- 14 welded joints
- Available in Red and Black

ROY 718 Square Back Chair



ROY 718B





### Table Tops

- Reversible
- Made of high impact melamine
- 1" thick with T-molding edge
- Available in walnut/oak or add (BM) suffix for black/mahogany finish



#### Round

ROY RTT 24 RT	24" dia
ROY RTT 30 RT	30" dia
ROY RTT 36 RT	36" dia

#### Square

ROY RTT 2424 T	24" x 24"
ROY RTT 3030 T	30" x 30"
ROY RTT 3636 T	36" x 36"

#### Rectangular

ROY RTT 2430 T	24" x 30"
ROY RTT 2442 T	24" x 42"
ROY RTT 3042 T	30" x 42"
ROY RTT 3048 T	30" x 48"

### Levelers

- 1" stem



	Type	Thread	Base
26-3784	Cushion Glide	1/4" - 20 Thread	7/8" dia
26-3790*	Nylon Base	5/16" - 18 Thread	1 1/8" dia
28-1576	Non-Skid	1/4" - 20 Thread	1 1/8" dia
28-1619	Non-Skid	5/16" - 18 Thread	1 1/8" dia

\*1 1/2" stem

### Self-Leveling Glide

- Eliminates wobbling
- Self-adjusts up to 1/4"
- 1 1/8" base dia
- 25-140 lb load capacity for a set of 4

26-3782 1/4" - 20 Thread



### Round Bases

- Cast iron base with black finish
- 3" diameter black steel column
- Heavy-duty nickel plated glides

	Base	Tabletop Size
ROY RTB 17R	17" dia	24" to 30"
ROY RTB 22R	22" dia	36", 24" x 30" or 24" x 42"
ROY RTB 30R	30" dia	30" to 42" or 42" to 60"



ROY RTB 17R



### Cross Bases

- Cast iron base with black finish
- 3" diameter black steel column
- Heavy-duty nickel plated glides

	Base	Tabletop Size
ROY RTB 2222	22" x 22"	24" to 30" rd or sq
ROY RTB 2230	22" x 30"	24" x 42" or 30" x 48"
ROY RTB 3030	30" x 30"	36" to 42" rd or sq
ROY RTB 3333	33" x 33"	Up to 60" Round
ROY RTB 5222	60" x 22"	Rectangular Top



ROY RTB 2222

### Stand-Up Bases

- 19" chrome wagon wheel foot rest
- Cast iron spider & base
- 3" dia x 37" tall steel column
- Nickel plated glides
- Use with 24" to 30" round or square tabletops

ROY RTB 142	22" x 22"
ROY RTB 143	22" Round



ROY RTB 143



# FURNITURE



## Reversible Table Tops



Oak/Walnut		Mahogany/Black		Oak/Walnut		Mahogany/Black	
<b>Round</b>							
-	91211	24" dia		91122	91222	24" x 30"	
91112	91212	30" dia		-	91223	24" x 36"	
91113	91213	36" dia		91124	91224	24" x 42"	
-	91216	48" dia		91126	-	24" x 48"	
91117	91217	60" dia		91134	91234	30" x 42"	
<b>Square</b>							
91121	91221	24" x 24"		91135	-	30" x 45"	
91132	91232	30" x 30"		91136	91236	30" x 48"	
91143	91243	36" x 36"		-	91237	30" x 60"	
				91138	-	30" x 72"	

## Waiter Stations

- Melamine laminate
- PVC edging on doors and drawers
- Roller bearing self-closing drawers
- Matching adjustable interior shelves and melamine cabinet back
- Door models feature European door hinges
- 3' working height, 2' deep
- Available in Black or Walnut finish



ROY 726	1 Drawer, 1 Adjustable Shelf, 2' long
ROY 727	1 Drawer, 2 Pair S/S Rack Slides, 2' long
ROY 728	1 Drawer, 1 Adjustable Shelf, 3' long
ROY 729	2 Drawers, 2 Adjustable Shelves, 2 Doors, 4' long



ROY 729



ROY 733B

ROY 733W



## Podium/Maitre D' Station

- Made from laminated melamine
- Touch latch doors
- 25" w x 22 1/2" d x 46" h
- Available in Black (B) or Walnut (W) finish



ROY 733	Without Casters
ROY 734	With Casters





CH-61200-18-BL-GG



XU-DG-TP001-GG



CH-51080-40-RED-GG

CH-31320-30GB-RED-GG

### Metal Seating

- For indoor or outdoor use
- Chair and barstools have drain holes in seat
- Stackable



Table - 24" dia x 41"h	Style	Finish
CH-51080-40-RED-GG	Cafe	Red Powder Coat
Chairs - Curved Back w/Vertical Slat Back		
XU-DG-TP001-GG	Bistro	Clear Coat Finish
CH-61200-18-BL-GG	Industrial	Blue Powder Coat Finish
Barstools - Curved Back w/Vertical Slat Back		
CH-31320-30GB-RED-GG	Bistro	Red Powder Coat Finish
ET-3534-30-DB-GG	Bistro	Distressed Green-Blue Powder Coat Finish



TLH-015-GG



TLH-017W-GG

### Cafe-Style Aluminum Chairs

- For indoor and outdoor use
- Stackable
- Triple slat back



TLH-015-GG	Side Chair w/Silver Slats
TLH-017W-GG	Armchair w/Faux Teak Slats

### Metal & Wood Indoor Seating

XU-DG694BLAD-CLR-WALW-GG  
Ladder Back Metal Chair, Clear Coat Finish, Walnut Wood Seat

XU-6F8B-CLR-BAR-BLKV-GG  
"X" Back Metal Barstool, Clear Coat Finish, Black Vinyl Upholstered Seat

XU-DG-W0006BAR-MAH-GG  
School House Back Wood Barstool, Mahogany Frame Finish, Beechwood Seat



XU-DG694BLAD-CLR-WALW-GG

Walnut Wood Seat



XU-6F8B-CLR-BAR-BLKV-GG

2½" thick Padded Upholstered Seat



XU-DG-W0006BAR-MAH-GG

1" thick Beechwood Seat



## Sunset Seating

- Featuring Microban® antimicrobial treated fabric
- Made with Grosfillex technopolymer with Air Molding Technology (AMT) for weather resistance and durability
- Nylon footpads to resist wear on hard surfaces
- 3 year warranty

<b>Barstools</b>	<b>Armchairs</b>	
US469599	US646599	Cognac/Fusion Bronze
US015599	US007599	Beige/Fusion Bronze
US469288	US646288	Solid Gray/Volcanic Black
US015288	US007288	Madras Blue/Volcanic Black
US017288	US011288	Beige/Volcanic Black
US469289	US646289	Solid Gray/Platinum Gray
US469096	US646096	White/Glacier White
US015096	US007096	Madras Blue/Glacier White
US017096	US011096	Beige/Glacier White



## Sunset Dining Tables

- Sold complete with top and base

### Table Tops

- Made of durable, uniquely finished HPL sheet for a lasting dramatic effect
- Resists fingerprints, scratches and smudges
- Ready to assemble on coordinating table base
- Umbrella hole with protective ring and plug for standard 1½" umbrella pole
- Easy to clean with soap and water
- 3 year warranty

### Table Bases

- Full Sunset cast metal design with a satin finish
- Will not rust nor get hot in the sun
- Ready to assemble flush with Grosfillex table tops
- Leg levelers for uneven surfaces
- 3 year warranty

<b>36" Square</b>	<b>42" Round</b>	<b>48" Round</b>	
UT36C599	UT42C599	UT48C599	Lava/Fusion Bronze
UT36C096	UT42C096	UT48C096	White/Glacier White
UT36C289	UT42C289	UT48C289	Granite/Platinum Gray
UT36C288	UT42C288	UT48C288	Granite/Volcanic Black

### 28" Square, Bar Height

UT351599	Lava/Fusion Bronze
UT351289	Granite/Platinum Gray
UT351096	White/Glacier White
UT351288	Granite/Volcanic Black



### Sunset Low Table

- Stylish and functional open-slat tabletop
- Colors match the Sunset Chaise, Chair, Barstool and Deep Seating frames
- Made of lacquered aluminum for years of worry-free use
- 20" sq
- 1 year warranty

US040599	Fusion Bronze
US040096	Glacier White
US040289	Platinum Gray
US040288	Volcanic Black

### Sunset Armless Deep Seating

- Microban® Textilene fabric dries quickly and retains its good looks with anti-UV and antibacterial properties
- Constructed of aluminum, fiberglass, and high quality resin
- Non-skid footpads
- Chaise Lounge features recessed wheels for ease of relocation

<b>Loveseat</b>	<b>Chaise Lounge</b>	
US002599	US642599	Cognac/Fusion Bronze
-	US023599	Beige/Fusion Bronze
-	US642288	Solid Gray/Volcanic Black
US002288	US023288	Beige/Volcanic Black
-	US021288	Madras Blue/Volcanic Black
US002289	US642289	Solid Gray/Platinum Gray
US002096	US330096	White/Glacier White
-	US023096	Beige/Glacier White
-	US021096	Madras Blue/Glacier White

### Sunset Cocktail Table

- Made of lacquered aluminum for years of worry-free use
- Open-slat tabletop is fresh and functional
- 1 year warranty

US004599	Fusion Bronze	US004289	Platinum Gray
US004096	Glacier White	US004288	Volcanic Black

### Arms for Sunset Deep Seating

- Made of high quality resin
- Easy to install
- 3 year warranty

US416599	Fusion Bronze	US416289	Platinum Gray
US416096	Glacier White	US416288	Volcanic Black



# FURNITURE



Vogue barstool with square tabletop and Tilt-top base

## Commercial Resin Furniture

- Prime synthetic resin with ultraviolet inhibitors for outstanding durability
- Chairs stack for easy storage
- Tables have adjustable leg levelers to balance the table on uneven surfaces



## Vogue Stacking Furniture

- Indoor/outdoor use
- Barstools feature powder-coated aluminum seating & legs
- Contoured
- Slotted resin back
- Resin seat and frame on chairs
- UV resistant
- Recyclable

Armchairs	Side Chairs	Barstools	
US633017	US637017	US638017	Black
US633181	US637181	US638181	Taupe

## Square Molded Melamine Table Tops

- Trendy marble, granite finish, or deco tops
- Stain, burn, scratch and fade resistant
- Without umbrella hole

24" x 32"	32" x 32"	
UT220742	UT230742	Aged Oak
UT220781	UT230781	Tokyo Stone
UT220008	UT230008	Teak Décor

## Alpha Resin Base, Small

- 19" diagonal footprint x 28"h

55631802	Charcoal
55631837	Bronze
55631181	Taupe
55631804	White
55631808	Teakwood

## X-One Tilt-Top Bases

- Patented folding system

Small	
USX15009	Silver Gray
USX15017	Black
Bar Base	
USX1H009	Silver Gray
USX1H017	Black
Large	
USX1W009	Silver Gray
USX1W017	Black



## Wicker Decor Furniture

- Made from prime synthetic resin with ultraviolet inhibitors for outstanding resistance to color fading and weather conditions
- Passes stringent testing – safe and effective for commercial use
- Molded melamine tables
- Chairs stack for easy storage



## Atlanta Tables w/Wicker Décor

UT370018	Square Table, 32" x 32"
UT375018	Square Table, 36" x 36"
UT385018	Rectangular Table, 48" x 32"

## Java Stacking Chairs

- Blends wicker with resin for strength, style and comfort
- Barstools feature powder-coated aluminum seat & legs

Armchairs	Sidechairs	Barstools	
US926037	US925037	US927037	Bronze
US926002	US925002	US927002	Charcoal

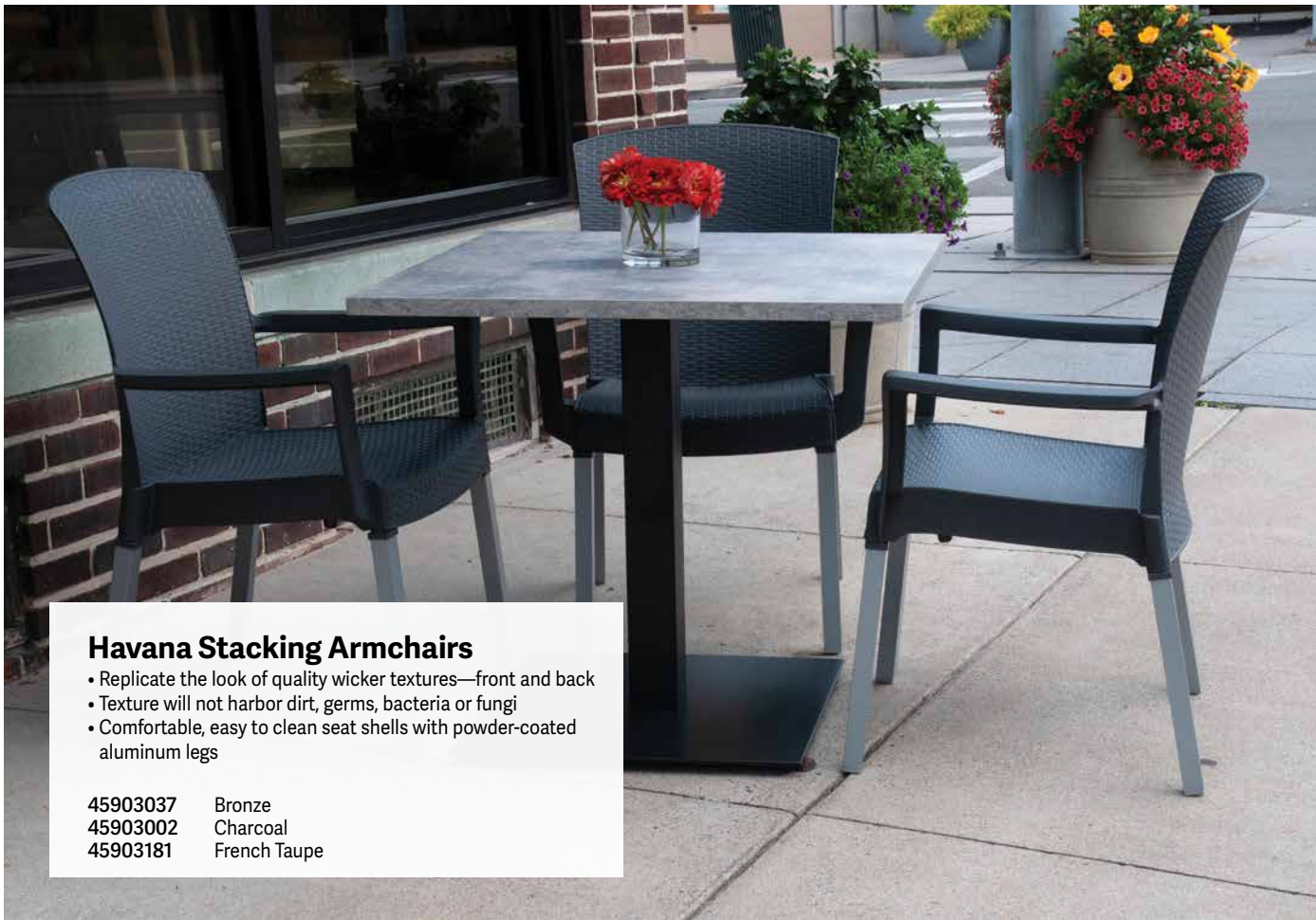

**Havana Stacking Armchairs**

- Replicate the look of quality wicker textures—front and back
- Texture will not harbor dirt, germs, bacteria or fungi
- Comfortable, easy to clean seat shells with powder-coated aluminum legs

45903037 Bronze  
 45903002 Charcoal  
 45903181 French Taupe



**Commercial Resin Furniture**

- Prime synthetic resin with ultraviolet inhibitors for outstanding resistance to color fading and weather conditions
- Chairs stack for easy storage
- Tables have adjustable leg levelers to balance the table on uneven surfaces

**Atlanta Tables**

- Elegant table features modern design with a molded melamine top
- Retains its original color and beauty without graying - no oiling, sanding, or refinishing to be done
- Umbrella hole with cap accommodates umbrella with a 1/2" pole

UT370008 32" Square Folding Table, Teak Décor  
 UT375008 36" Square Folding Table, Teak Décor  
 UT385008 32" x 48" Folding Table, Teak Décor

**Acadia Classic Stacking Armchairs**

- Classy ladder-back design
- Wood grained with a satin finish
- Contoured seat and back for ergonomic comfort

46 1190 08 Teakwood (shown)  
 46 1190 04 White

Atlanta tables

Acadia armchairs



# FURNITURE

## Wooden Market Umbrellas

- 8 reinforced ribs with top vent
- 1½" dia wooden pole
- 95% sunscreen
- All brass hardware to resist corrosion
- Outdura® solution-dyed acrylic traditional fabric
- Pulley facilitates easy opening and closing
- Fade, stain and mildew resistant
- Bases and umbrellas sold separately
- 5 year limited fade warranty on fabric



Custom canopy colors also available

### 7' Umbrellas

- 98940331 Khaki
- 98949731 Pacific Blue
- 98944831 Sand
- 98940431 White
- 98942031 Forest Green
- 98944931 Pesto
- 98948131 Taupe
- 98943131 Turquoise
- 98948231 Terra Cotta
- 98942731 Burgundy

### 9' Umbrellas

- 98910331 Khaki
- 98919731 Pacific Blue
- 98914831 Sand
- 98910431 White
- 98912031 Forest Green
- 98914931 Pesto
- 98918131 Taupe
- 98913131 Turquoise
- 98918231 Terra Cotta
- 98912731 Burgundy



Several styles and colors of umbrella bases available, please ask your sales representative.



## Windmaster Umbrellas

- Built to better sustain the unpredictable abuses of the wind
- 1½" diameter aluminum pole
- Replaceable fiberglass ribs
- Extra large vent to release the pressure
- Colorfast, easy to maintain Recacril® Marine Grade solution-dyed acrylic fabric
- Bases and umbrellas sold separately
- Custom logo available
- 5 year limited fade warranty on fabric



### 7½' Umbrellas

- 98319431 Sky Blue
- 98380331 Khaki
- 98389731 Pacific Blue
- 98342531 Canvas
- 98386031 Navy
- 98382031 Forest Green
- 98342431 Pistachio
- 98318131 Taupe
- 98324131 Turquoise
- 98318231 Terra Cotta
- 98301931 Orange

### 9' Umbrellas

- 98819431 Sky Blue
- 98820331 Khaki
- 98829731 Pacific Blue
- 98842531 Canvas
- 98826031 Navy
- 98822031 Forest Green
- 98842431 Pistachio
- 98818131 Taupe
- 98824131 Turquoise
- 98818231 Terra Cotta
- 98801931 Orange



## Medium-Duty Bar Blenders

- 1 hp commercial motor
- 1-piece, 48 oz BPA-free copolyester container with industrial stainless steel blade
- Removable rubberized jar pad
- 2-speed motor with pulse function
- Recommended for 25 to 49 drinks per day
- Limited 1 year warranty
- Made in the USA

BB300 With Electronic Keypad  
BB320 With Toggle Switches



Toggle switches

BB300  
NSF  
ETL  
Intertek



## One Gallon Food Blender

- Stainless steel clover-leaf container
- Rubberized lid
- Two handle container
- Membrane keypad with low-med-high, pulse and Slow Start™
- Base is easy to clean and transport
- 3¾ hp, 3-speed motor
- 120V
- Limited 3 year motor warranty
- Made in the USA

CB15 With 1 Gallon S/S Container



**WARING**  
COMMERCIAL



BAR

## Xtreme Heavy-Duty Food & Beverage Blenders

- Heavy-duty, 3½ peak input HP motor, max pulse with up to 30,000+ RPM burst of speed
- One-piece, dishwasher-safe, removable jar pad
- All materials that come in contact with food are BPA-free
- Heavy-duty stainless steel blade with user-replaceable blending assembly
- Optional sound enclosure reduces noise by over 50%
- Add suffix for container type: 64 oz BPA-free copolyester container (-XTX), 48 oz BPA-free copolyester container (-XTXP) or 64 oz stainless steel container (-XTS)
- Limited 3-year motor and 2-year parts and labor warranty

- MX1000 Paddle Switches w/HIGH, LOW & PULSE
- MX1050 Electronic Membrane Keypad w/HIGH, LOW & PULSE
- MX1100 Electronic Keypad w/HIGH, LOW & PULSE and 30-Second Timer
- MX1200 Variable Speed Control Dial and PULSE Paddle Switch
- MX1300 Programmable Electronic Keypad, LCD Display and PULSE
- MX1500 Programmable Electronic Keypad, LCD Display and PULSE, Sound Enclosure

**WARING**  
COMMERCIAL



MX1050XTX  
Electronic  
Membrane  
Keypad  
Control



MX1200XTX  
Variable  
Speed  
Control



MX1500XTX  
Adjustable  
Speed  
Controls,  
Sound  
Enclosure

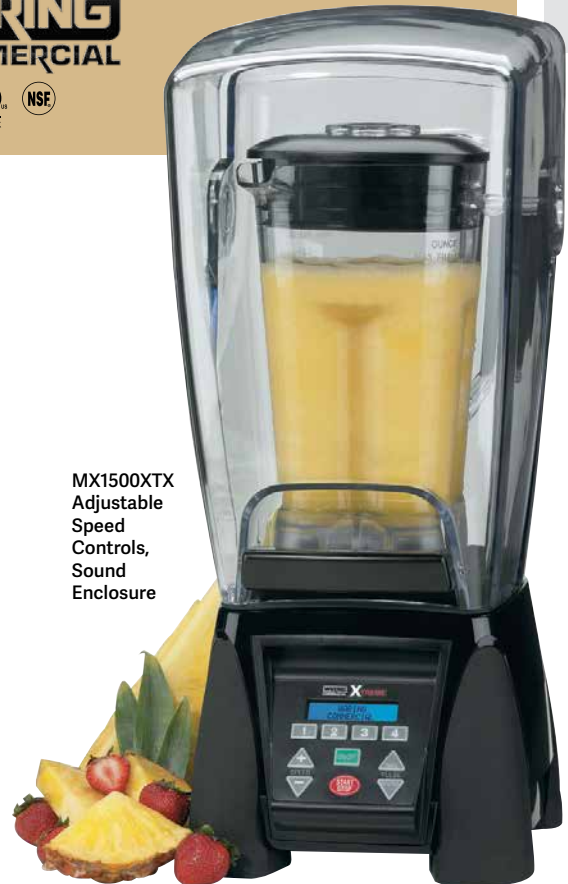

**Basic Bar Blenders**

- ¾ hp, 2-speed commercial motor
- Rugged, one-piece stainless steel cutting blade
- User-replaceable, metal-reinforced rubber drive coupling
- Recommended for up to 25 drinks per day
- 120V
- Limited 1 year warranty

BB155S With 32 oz S/S Container

BB155 With 44 oz BPA-free Copolyester Container



BB155S



BB155



**TORQ 2.0 Blenders**

- High performance 2 hp, 2-speed motor with 24,000 max RPM
- Durable stainless steel, user-replaceable drive coupling
- Blend three 16 oz margaritas in 8 seconds or less
- 48 oz stackable, BPA-free co-polyester jar
- Available in three control configurations
- Limited 2 year warranty



Touchpad Controls



TBB145

- TBB145 Classic Toggle Switch Design
- TBB160 Electronic Touchpad Controls
- TBB175 Electronic Touchpad Controls w/Variable Speed Control Dial

**Commercial Bar Blender**

- Super powerful with 3 hp motor
- Our quietest heavy-duty blender
- Versatile High/Low On/Off controls
- BPA free Triton container
- 2 year limited warranty

BLE-300 64 oz



**Commercial Bar Blender**

- Two speed motor with the perfect clutch coupling system
- The most ice crushing power in its class
- Two toggle switches, On/Off and Low/High
- 110-130V, 1 hp

BLE-110 48 oz



## Bar Spoons

- A variety of styles and sizes to simplify cocktail mixing
- Precision formed bowl for proper capacity, easy stirring and smooth transfer

- One-piece construction for greater durability and sanitation
- Twisted design for control and grip
- 18/8 stainless steel core

Stainless Steel	Copper Plated	Gold Plated	
M37010	M37010CP	M37010GD	Japanese Style, 13 <sup>3</sup> / <sub>16</sub> " long
M37011	M37011CP	M37011GD	Japanese Style, 17 <sup>7</sup> / <sub>8</sub> " long
M37012	M37012CP	M37012GD	Classic Style, 11 <sup>3</sup> / <sub>16</sub> " long
M37013	M37013CP	M37013GD	Classic Style, 15 <sup>3</sup> / <sub>4</sub> " long
M37014	M37014CP	M37014GD	Classic Style, 19 <sup>5</sup> / <sub>8</sub> " long
M37015	M37015CP	M37015GD	Fork Style, 12 <sup>3</sup> / <sub>8</sub> " long
M37016	M37016CP	M37016GD	Fork Style, 15 <sup>3</sup> / <sub>4</sub> " long
M37017	M37017CP	M37017GD	Fork Style, 19 <sup>5</sup> / <sub>8</sub> " long
M37018	M37018CP	M37018GD	Muddler Style, 11 <sup>3</sup> / <sub>16</sub> " long
M37019	M37019CP	M37019GD	Muddler Style, 15 <sup>3</sup> / <sub>4</sub> " long



Machine end for handling small quantities of ingredients



Japanese Style End

Weighted end for fast and easy mixing



Classic Style End

Fork end for spearing garnishes



Fork Style End

Flat top end designed for muddling



Muddler Style End



## Cocktail Picks

- 18/8 stainless steel core
- Sharp point quickly and cleanly pierces garnishes
- Designed so it will not fall into martini glasses
- 4<sup>3</sup>/<sub>8</sub>" long
- Pack of 12

M37030SS	Stainless Steel
M37030CP	Copper Plated

## Bar Strainers

- Heavy-duty to filter ice and other solids
- Stainless steel for excellent durability



Stainless Steel	Copper Plated	Gold Plated	
M37026	M37026CP	M37026GD	Heavy-Duty Spring Strainer, 6" long
M37028	M37028CP	M37028GD	Julep Strainer, 6 <sup>1</sup> / <sub>2</sub> " long
M37037	M37037CP	M37037GD	Classic Hawthorne Spring Strainer, 6 <sup>1</sup> / <sub>2</sub> " long
M37029	M37029CP	M37029GD	Scalloped Julep Strainer, 7" long



M37026

Integral prongs to balance on shaker or glass



M37028

Optimal perforation pattern for fast draining



M37037

Bend-in handle to rest on shaker or glass



M37029

Classic strainer with long handle and optimal perforation

## Double End Stirrer

- One-piece construction for greater durability and sanitation
- Twisted design for control and grip
- 18/8 stainless steel core
- 13<sup>3</sup>/<sub>16</sub>" long



M37020	Stainless Steel
M37020CP	Copper Plated
M37020GD	Gold Plated



Dual weighted ends for smooth stirring of cocktails

## Fine Mesh Strainer

- Fine mesh allows for double straining of drinks to remove small amounts of pulp, herbs and ice
- Comfortable rod handle with front rest loop to sit on glass for one hand operation
- 18/8 stainless steel

M37025  
3<sup>1</sup>/<sub>2</sub>" dia bowl, 10<sup>3</sup>/<sub>8</sub>" long overall



## Bar Shakers

- Heavy-gauge 18/8 stainless steel to maintain shape
- Satin finish interior to hide wear
- Mirror finish exterior for an elegant appearance
- Capped bottom for greater durability



### Stainless Steel

- M37007 18 oz Shaker
- M37008 28 oz Shaker
- M37009 18 & 28 oz Shaker Set

### Copper Plated

- M37007CP 18 oz Shaker
- M37008CP 28 oz Shaker
- M37009CP 18 & 28 oz Shaker Set

### Gold Plated

- M37007GD 18 oz Shaker
- M37008GD 28 oz Shaker
- M37009GD 18 & 28 oz Shaker Set



## Composite Muddler

- Food grade polypropylene
- Textured bottom for more efficiency

M37022 8¼" long

## Wood Muddler

- Natural wood construction

M37060 7¾" long



## Ice Pick

- Heavy-duty cast stainless steel head with sharp edge for scoring ice to create desired shapes
- Sharp point to break apart ice blocks
- Comfortable wood handle

M37024 7" long



## Jiggers

- Internal measurement lines with markings for greater flexibility
- Japanese-style jiggers feature a rolled top edge to strengthen and maintain shape
- External markings with capacity per size
- 18/8 stainless steel core



Japanese Style

Stainless Steel	Copper Plated	Gold Plated	Capacity
Japanese Style			
M37000	M37000CP	M37000GD	½ x ¾ oz
M37003	M37003CP	M37003GD	1 x 1½ oz
M37005	M37005CP	M37005GD	1 x 2 oz
M37001	M37001CP	M37001GD	20 ml x 40 ml
M37002	M37002CP	M37002GD	25 ml x 50 ml

Straight Rim Bell Style			Capacity
M37006	M37006CP	M37006GD	1 x 2 oz



Straight Rim Bell

## Cast Aluminum Juicer

- Strong, lightweight cast aluminum
- Accommodates limes and small lemons
- Stainless steel pin for greater strength
- Top loop allows for convenient hanging

M37023 8½" long





BAR



BS203



BS204



BS207

**Bar Kits**

- These sets are assembled to equip your bar with the base components



**BS203 - 7 Piece Kit Includes:**

- ¾ oz x 1¼ oz Jigger
- Waiter's Corkscrew
- Bottle Opener
- 6" Ice Tongs
- 4-Prong Bar Strainer
- 11" Twist-Handle Bar Spoon
- 4 Black Pourers
- 16 oz Mixing Glass with Recipes

**BS204 - 8 Piece Kit Includes:**

- ¾ oz x 1¼ oz Jigger
- Bottle Opener
- 6" Ice Tongs
- 2-Prong Bar Strainer
- Mixing Paddle
- Serrated Knife
- Stainless Steel Ice Bucket

**BS207 - 13 Piece Kit Includes:**

- 16 oz Shaker & 28 oz Shaker
- ¾ oz x 1¼ oz Jigger
- Corkscrew
- Speed Opener
- 4-Prong Bar Strainer
- 11" Twist-Handle Bar Spoon
- 6 Black Pourers

**Vinyl Wrapped Shakers**

- Vinyl wrapped stainless steel shakers give bartenders an extra grip so no drinks are spilled when mixing
- 28 oz capacity



- CS100VGRN Stainless Steel Cup w/Green Vinyl Wrap
- CS100VBLU Stainless Steel Cup w/Blue Vinyl Wrap
- CS100VRED Stainless Steel Cup w/Red Vinyl Wrap
- CS100VBLK Stainless Steel Cup w/Black Vinyl Wrap

**Copper Barware Accessories**

- Copper has a long history of being used in making many classic drinks
- These new copper products will stand out at any of your events or in bar kits
- Constructed of high quality copper plated stainless steel to withstand the rigors of the foodservice industry
- Three piece sets include shaker, strainer and jigger



- CO3COP Long Neck Bottle Opener, 7" long
- SP511COP Twisted Handle Spoon w/Muddler, 11" long
- BS209COP 4-Prong Strainer
- J197COP Jigger, 1 oz/2 oz
- CS100COP Shaker, 28 oz
- CSJ5134COP 3-Piece Shaker Set, 8 oz
- CSJ5135COP 3-Piece Shaker Set, 16 oz
- MP285CO-COP Tapered Pourer, Pk 1 dz
- MM-20COP Moscow Mule, 20 oz
- IG4500COP Ice Bucket, 8½" dia x 8"h

## First In, First Out Garnish Stations

- Patented first in, first out stackable design for fresh condiments
- Durable ABS plastic
- Space behind inserts allows for ice storage
- Plastic cover keeps condiments protected
- Bin dividers included
- Dishwasher safe
- 20½" w x 6¾" d x 6½" h



BCD6000	(6) 1¼ pt White Inserts
BCD6100	(1) 1¼ qt & (4) 1¼ pt White Inserts
BCD6000BK	(6) 1¼ pt Black Inserts
BCD6100BK	(1) 1¼ qt & (4) 1¼ pt Black Inserts



BCD6000

## On The Rocks Ice Cooled Condiment Holder

- Fits on standard mixing rails
- Domed top lid for extra room for garnish
- (6) 1 pint inserts
- 17¼" x 4¾" x 5¼"

CHD001	White
CHD003	Black



## Roll Top Condiment Holder

- Fits on standard mixing rails
- Domed top lid for extra room for garnish
- Black tray with clear lid
- 18½" x 6½" x 6½"

CD0160	(6) 1 pt Inserts
--------	------------------



## The Dome® Garnish Center

- Domed lid rotates back for easy access and increased capacity
- Includes (6) 1 pt standard chillable trays; 2 snap-on caddies, 2 handles
- Tailored to fit on standard mixing rails
- Space under standard trays for ice/ice packs
- Snap-on caddies store picks, sticks and straws
- Black



BD4006S	22" l x 7½" w x 8½" h
---------	-----------------------



## Ice Scoops

- 18/8 stainless steel
- Dishwasher safe
- Drain holes prevent melted ice from watering down drinks



BSC0610	6-10 oz
BSC1216	12-16 oz
BSC2024	20-24 oz



## SPILL-STOP MFG. CO.

### Ban-M® Liquor Pourers

- "The one with the screen"
- Non-measuring
- Keeps insects out
- Made in USA

313-00	Clear	313-04	Green
313-02	Black	313-05	Blue
313-03	Red	313-06	Amber



### Plastic Pourers

- Molded of an extremely soft, flexible material that will last indefinitely
- Made in USA

350-00	Semi-Clear	350-05	Blue
350-01	Sparkle Red	350-06	Yellow
350-02	Sparkle Green	350-07	White
350-03	Fluorescent Red	350-08	Black
350-04	Green	350-09	Scarlet Red

## How To Properly Clean Pourers

- Do not use abrasive detergents
- Do not use very hot water on metal pourers
- Soak pourers in warm, soapy water for at least 10-15 minutes
- Rinse well in cold water
- Clean at least every two weeks

To learn more visit: [blog.sculpturehospitality.com](http://blog.sculpturehospitality.com)

### Chrome Tapered Pourer

- Seamless, tapered spout allows controlled, medium speed pouring
- Made in USA

285-50 With Poly-Kork



The most popular pourer in the world

## SPILL-STOP MFG. CO.



### Posi-Por™ Measuring Pourers

- Available in ten sizes from 1/2 oz to 2 oz
- Made in USA

387-1	Clear, No Collar
387-2	Clear, Black Collar
389-1	Red, No Collar
389-2	Red, Black Collar

### Freshforce Juicers

- Unique dual gear mechanism produces up to 20% more juice than conventional juicers and offers more pressing power
- Constructed of strong glass filled nylon for maximum durability
- Strains virtually all pulp and seeds

102-159-017 Citrus  
102-415-011 Lime

**TAYLOR**



102-415-011

102-159-017



### Cast Aluminum Handheld Citrus Squeezers

- Get pure juice without any seeds or pulp
- Enameled surface resists pitting and corrosion
- Color-coded for easy identification

8563 8" Lime Squeezer, Green  
8565 8¾" Lemon Squeezer, Yellow  
8566 9" Orange Squeezer, Orange

**FOCUS**  
FOODSERVICE  
A CROWN BRANDS COMPANY



### 2-In-1 Handheld Citrus Squeezer

- Move the dual-sided center plate up to juice lemons or leave it down to juice limes

8720 8¾" long

### Universal Speed Rails

- Stainless steel
- Adjustable length
- Holds quart or liter bottles



#### Single Speed Rails

512232 Adjustable from 22" - 32", Holds (8) Quart/Liter Bottles

513242 Adjustable from 32" - 42", Holds (10) Quart/Liter Bottles

#### Hanger Strap Set

5300 3-Strap Set



### Bar Mop Towels

- Ribbed terry
- 16" x 19"
- White



LBMR 24 oz  
BMR 28 oz





### Versa-Mat® Shelf Liner

- 12" x 12" square interlocking sections snap together for any size
- Perfect for lining your bar and dinnerware shelving
- Lightweight and can be easily cut to fit into any shape
- Raised, non-slip surface provides protection against marring of glassware and china
- Commercial dishwasher safe
- Design allows for sanitary airflow under glassware

• Available in: Black (BK), Clear (CL), Red (RD) and Wine (WN)

VM5280 12" x 12" x 1/2" thick



### Kleen Plug™ Beer Tap Plugs

- Eliminates the time and waste of wrapping beer taps when not in use, as required by health codes
- Durable brush removes yeast and sediment from taps for better tasting beer
- Dishwasher safe



KLP200 Blister Pack, 5/pk  
KLP250 Bulk Pack, 50/pk



### Fly-Bye™ Fruit Fly Traps

- Utilizes a 2 part, food-based attractant to entice fruit flies into the trap where they are unable to escape
- Disposable and recyclable
- Non-toxic
- Each trap lasts up to 30 days
- Contains no VOCs (Volatile Organic Compounds)



FLY-BYE 2 Per Pack

## Glass Pro By Bar Maid®



AA



AA-SUB



### Electric Glass Washers

#### Upright

- Wash more glasses faster with a Glass Pro
- Installs in virtually any bar sink in seconds
- 5 brushes scrub inside and out simultaneously

- No racks to load/unload - handle glassware once
- GFCI protected, available only on the 120V 60Hz
- CE (230V only)
- ETL to CSA, NSF
- Made in the USA

AA Upright

#### Submersible

- 5 brushes scrub inside and out simultaneously
- Compact design fits virtually all bar sinks
- Quiet 1/3 hp motor helps keep water warm

- Easily removes lipstick and fruit pulp
- GFCI protected, available only on the 120V 60Hz
- CE (230V only)
- ETL to CSA, NSF
- Made in the USA

AA-SUB Submersible



### Commercial Glass Polisher

- Simultaneously polishes glassware inside and out while drying with the warm air blower
- Soft lint-free twine material reduces potential for breakage
- Polishes up to 350 glasses per hour
- Small and lightweight with built-in handles
- 11 1/2" w x 13" l x 20" h

GP-100 110V, 1350W

Ready to learn more about these great products?

**PLAY VIDEO**



BAR

# BAR



## Add-On Blender Stations

- Stainless steel 6" deep sink bowls, backsplash, shelf and sides
- Galvanized back and bottom
- Electrical: Duplex outlet located underneath
- ½" IPS hot and cold water, 1½" IPS drain connection
- Galvanized legs
- 4" center splash mount faucet
- 22½" d x 30" h

18-12BD 12"w, 10" x 12" Sink

18-18BD 18"w, 10" x 14" Sink

18-12BD



## Liquor Display

- Embossed stainless steel steps
- Holds approximately 28 standard size bottles
- 4 tier
- 1½" IPS drain connection
- Stainless steel backsplash sides and rails
- Galvanized steel back and legs

18-24RD 24"w x 24" d x 36½" h



18-W66R



## Workstations

- The perfect bartender workstation
- 24" drainboard on left for glass storage, 24" l x 12" d ice bin, and 18" blender/dump sink
- Includes commercial series wall mount faucet, two removable 3-pack bottle racks and 1" drains
- Optional built-in 7 circuit cold plate for soda system is highly recommended to meet local health requirements
- 5'6" l x 22½" d or 25" d

18-W66R Without 7 Circuit Cold Plate

18-W66R-7 With 7 Circuit Cold Plate



## Speed Rails

- 20 gauge stainless steel
- Available in single and double tier style
- Keyhole mount
- Double speed rail has 2 levels

Single	Double	Length
S-24	D-24	24"
S-30	D-30	30"
S-36	D-36	36"
S-48	D-48	48"

S-24

S-30

S-36

S-48



S-24



D-24



## Underbar Drainboard

- Stainless steel construction
- 1" drain in drainboard top
- Requires 1" IPS drain connection

18-GS24 24"w x 18½" d x 33" h

# BarFlex3D™

by 

## LET US DESIGN YOUR BAR

BarFlex3D™ - Customize your own Craft Cocktail station!

- 3D rendering
- Over 10,000 configurations
- New options added monthly
- Top of the line underbar built for durability, bartender efficiency and first class appearance
- Available with legs or bar die wall construction
- Built-in sound deadened speed rails
- Full layout and design available
- Pre-assembled and shipped in sections up to 7' to save time on installation



Instant 3D Renderings  
Over 10,000 Configurations  
New Options Added Monthly



BAR

## Ice Bins

- Complete line of ice bins available to meet your needs
- Available with optional built-in 7 circuit cold plate for soda systems
- Two removable 3 pack bottle racks included



NSF

18-24

Shown with Optional Speed Rail

	Length	Depth
18-24	2'	12"
18-36	3'	12"
18-24DP	2'	15"
18-36DP	3'	15"



NSF

## Glass Storage Bin

- Embossed stainless steel drainboard, stainless steel front, backsplash, sides, bottom and rack slides
- Galvanized back and 1 1/8" legs with plastic feet
- 1" IPS drain connection

18-GSB1 24"w x 23 1/2"d x 33"-34"h



NSF

18-53C

Shown with Optional Speed Rails

## Bar Sinks

- Complete line of bar sinks available to meet your needs
- Large 10" x 14" x 10" sink bowls with corner drains
- Embossed drainboards to keep glasses dry
- Complete with commercial series faucet, 1" drains and overflows

18-53C	5', 3 Compartment, (2) 12" Drainboards
18-63C	6', 3 Compartment, (2) 18" Drainboards
18-64C	6', 4 Compartment, (2) 12" Drainboards

# BUFFET & CATERING

Proprietary adapter and gap bars allow for a painless setup with minimal measuring.



Ask your sales representative about available colors.

## Bugambilia® Fit Perfect™ Cold Bar System

- Achieve a flush fit look with virtually no measuring and without any racks or risers
- Unique design securely holds food pans in place to prevent falling and shifting
- Edge-to-edge measurements match standard stainless steel food pans
- Stocked in White (WW) with smooth Mod™ finish; available in 23 colors



### Full Size Pans - 20.13" x 12.38"

CIH1F-WW 2.5" deep  
CIH1FD-WW 4" deep

### Half Size Pans - 12.31" x 10.06"

CIH1/2-WW 2.5" deep  
CIH1/2D-WW 4" deep

### Half Long Size Pans - 20.13" x 6.13"

CIH1/2L-WW 2.5" deep  
CIH1/2LD-WW 4" deep

### Third Size Pans - 12.31" x 6.69"

CIH1/3-WW 2.5" deep  
CIH1/3D-WW 4" deep

### Sixth Size Pans - 6.75" x 6.19"

CIH1/6-WW 2.5" deep  
CIH1/6D-WW 4" deep

### Adapter, Extension and Gap Bars

CIHSPC21-WW Adapter Bar, 20¾" long  
CIHSPC12-WW Extension Bar, 12" long  
CIHGAP10-WW Gap Bar, 1" wide  
CIHGAP15-WW Gap Bar, 1½" wide  
CIHGAP20-WW Gap Bar, 2" wide  
CIHGAP25-WW Gap Bar, 2½" wide  
CIHGAP30-WW Gap Bar, 3" wide



Gap Bar



Adapter Bar

CIH1F-WW



CIH1/2-WW



CIH1/3D-WW



CIH1/6D-WW

## Curv™ Serving Utensils

- Withstands temps from -40° to 212°F
- Available in Clear (C), Black (K) and Red (R)



CVST-6 Utility Tongs, 6"  
CVST-9 Utility Tongs, 9"  
CVST-12 Utility Tongs, 12"  
CVBS-10 Buffet Spoon, ¾ oz, 10"  
CVSS-13 Solid Serving Spoon, 13"

CVSS-15 Solid Serving Spoon, 15"  
CVPS-13 Perforated Serving Spoon, 13"  
CVPS-15 Perforated Serving Spoon, 15"  
CVLD-8 Ladle, ¾ oz, 8½"  
CVLD-13 Ladle, 1 oz, 13"





UPCHT800

**CAMBRO**  
TRUSTED FOR GENERATIONS™



UPC300



### Heated Ultra Pan Carrier® & Ultra Camcart®

- Gentle heat (150° to 165°F) warms and maintains food moisture
- Excellent temperature retention—even when unplugged for hours
- Tough polyethylene exterior stays cool to the touch
- 110V
- Ask your local sales representative for details about available colors

#### Heated Pan Carrier - 1 Compartment, Stackable

UPCH400 18½" w x 26¾" d x 24⅞" h

Heated Camcart® - 2 Compartment

UPCH800 20½" w x 27⅞" d x 54" h

Heated Camcart® - 2 Compartment, Heated Top Only

UPCHT800 20½" w x 27⅞" d x 54" h



### Ultra Camcarrier® & Camcart®

- Tough, 1-piece seamless, double-wall, polyethylene construction
- Air tight gaskets and full swing 270° doors
- Molded-in handles and bumpers
- Holds 2½" d to 8" d full size pans
- Casters on Ultra Camcart®: 2 fixed & 2 swivel, 1 braking
- Ask your local sales representative for details about available colors

#### Ultra Camcarrier® 1 Comp.

UPC300 17" w x 25¾" d x 22¾" h

UPC400 18" w x 25" d x 24⅞" h

#### Ultra Camcart® 2 Comp.

UPC600 20½" w x 27⅞" d x 45" h

UPC800 20½" w x 27⅞" d x 54" h

UPC1200 28½" w x 32¼" d x 45½" h

UPC1600 28¾" w x 33⅞" d x 54⅞" h

BUFFET & CATERING



### Top Loading Pan Carriers

- Retains internal temperature for hours
- Nylon latches
- Interlock stacking during transport and storage
- Polypropylene w/foam insulation
- Ask your local sales representative for details about available colors

#### 100 Series - 26½" w x 18" d x 15¼" h

UPC100 Holds from (1) 8" d to (3) 2½" d Full Size Pans

#### S-Series - 24½" w x 16½" d, Stackable

UPCSS160 Holds (1) 6" d Full Size Pan, 9⅞" h

#### S-Series - 25½" w x 17⅞" d

UPCS140 Holds (1) 4" d Full Size Pan, 8⅞" h

UPCS160 Holds (1) 6" d Full Size Pan, 10¼" h

UPCS180 Holds (1) 8" d Full Size Pan, 12" h

CP1210

**CAMBRO**  
TRUSTED FOR GENERATIONS™

300DIV

1210PW

### Camcarrier® & Camcart® Accessories

#### ThermoBarrier®

300DIV For UPC300 & UPC600, Color: Coffee Beige

400DIV For UPC400, UPSC400 & UPC800, Color: Gray

1200DIV For UPC1200 & 1200MPC, Color: Dark Brown

1600DIV For UPC1600 & CamKiosk Cart, Color: Slate Blue

#### Camchiller®, Cold Blue

CP1210 Half Size

CP1220 Full Size

#### Camwarmer®, Granite Gray

1210PW For UPC400, UPSC400, UPC300, UPC600 & UPC800

#### Divider Bars - Packed 3 ea

DIV12 12" Bar for Camcarrier®

DIV20 20" Bar for Camcarrier®

#### Camdolly, Ask About Available Colors

CD400 For UPC400 & UPSC400, 300 lb Capacity, 21⅞" x 28⅞" x 9"  
5" Casters: 2 Fixed, 2 Swivel, 1 w/Brake



### S-Series® Ultra Pan Carrier®

- Polyethylene construction
- Stores hot and/or cold foods
- Retains food-safe temperature without any external heat source
- Gasketless doors with built-in seal open 270° for easy loading/unloading
- Nylon latches
- Holds up to (6) 2½" d, (4) 4" d, (3) 6" d or (2) 8" d full size food pans
- Colors: Speckled Gray (480) and Dark Brown (131)

UPCS400 18" w x 26¼" d x 25" h



# BUFFET & CATERING



ETL  
Intertek  
90019



11005



90217



90014  
Shown  
with  
40062



## High Heat Butane Stoves & Accessories

- Automatic piezo electronic ignition
- Stoves include plastic carrying case and operate with an 8 oz butane canister (sold separately)
- 90011 & 90019 feature a heat transfer plate to maintain high heat output
- Chef's Torch burns up to 3 hours per 8 oz fuel canister



- 90027 Portable Butane Stove
- 90011 Premium Butane Stove, 10,000 BTU
- 90019 Premium Butane Stove, 15,000 BTU
- 90217 Butane Stove Cover, 14½" w x 7½" d x 12" h
- 40062 Butane Fuel Canister, 8 oz, 2-4 Hour Burn Time
- 90014 Professional Chef's Torch, Heats Up To 2,012°F
- 90022 Premium Butane Chef's Torch, Heats up to 2,192°F
- 11005 Butane Lighter



## Induction Range

- Stainless steel with ceramic top
- Touch screen operation
- 140° to 464°F temperature range
- Rear metal guard protects power cord and reduces overheating
- 1800W, 120V



IC-1800WN 15½" l x 12" w x 4¾" h



## Round Induction Chafer

- Vented glass top, mirror polished stainless steel
- Built-in slam resistant mechanism
- Rear stabilizer leg



ICH-21 14.18" dia, 6 qt

## Butane Stove

- Automatic piezo electronic ignition
- In line regulator with pressure-sensing shut off
- For indoor and outdoor commercial use
- For outdoor use only for camping

90235 12,000 BTU

## Insulated Food Carrier

- 1" padded foam insulation with water repellent nylon lining
- Features outside identity pocket
- Comfortable padded handles
- Zipper closure
- Red



FC2212-RD 22" w x 12" d x 12" h



### Idol™ Urn

- Elegant 18/10 stainless steel
- Includes base and fuel holder

WI12LU 3.2 Gallon Capacity



### Idol™ Chafer Kit

- 18/10 stainless steel
- Self closing, vented glass lids keep food presentations from drying out
- The body removed from the stand can be used on an induction table
- Magnetic steel clad bottoms ensure excellent heating
- Complete with chafer body, glass top lid, food pan, spoon holder, burner stand and 1 fuel cup



WI6LGL Round, 7 qt



### Lunar™ Full Size Chafers

- Adds elegance to any buffet
- Simple open function to 90°
- 8 qt capacity

L8HL Hammered Lid  
L8ML Mirror Polished Lid



### Chafer w/Folding Frame

- Lift-off cover
- Folding frame allows for easy transport and saves storage space
- Handy lid clips hold lid in place during service
- Elegant mirror finish

C-1080 Full Size, 8 qt



601

### Madison Chafers

- 18/8 stainless steel, mirror finished
- Roll-top cover can stop at any angle

602 Round, 6 qt  
603 Oval, 8 qt  
601 Full Size, 8 qt



603

Hollowick offers a full range of cooking fuels including various chafing fuels, butane fuels and high quality butane fuel accessories.



# BUFFET & CATERING



Mirror Finish

## Eclipse Serving Utensils

- 18/8 stainless steel
- "Stay cool" tapered, hollow handles
- Lengthy curved handle reduces slippage into chafing dishes

Ready to learn more about these great products?

**PLAY VIDEO** 



### Mirror Finish

- 573183 Pie Server, 10" long
- 573171 Solid Turner, 14¾" long
- 573172 Slotted Turner, 14¾" long
- 573182 Fork, 3 Tine, 10" long
- 573175 Fork, 2 Tine, 14" long
- 573180 Solid Serving Spoon, 10" long
- 573173 Solid Spoon, 13½" long
- 573181 Slotted Spoon, 10" long
- 573174 Slotted Spoon, 13½" long
- 573190 Wide Tongs, 12" long
- 573184 Ladle, 1 oz, 10" long

- 573185 Ladle, 1 oz, 12" long
- 573170 Ladle, 6 oz, 15" long
- 573192 Pom Tongs, 6" long
- 573194 Pom Tongs, 9" long
- 57540 Bar Tongs, 7" long
- 573186 Tongs, 6" long
- 573187 Tongs, 9½" long
- 573188 Tongs, 12" long
- 57567 Offset Tongs, 9" long
- 57568 Offset Tongs, 12" long

### Satin Finish

- 573283 Pie Server, 10" long
- 573271 Solid Turner, 14" long
- 573272 Slotted Turner, 14" long
- 573280 Solid Spoon, 10" long
- 573273 Solid Spoon, 13" long
- 573281 Slotted Spoon, 10" long
- 573274 Slotted Spoon, 13" long

- 573284 Ladle, 1 oz, 10" long
- 573270 Ladle, 6 oz, 14" long
- 573286 Tongs, 6" long
- 573287 Tongs, 9½" long
- 573288 Tongs, 12" long

### Satin Finish

573288



## Silicone & Stainless Steel Utensils

- Safe to use with coated cast aluminum items
- Heat safe to 400°F
- Black

- 39100 Tongs, 7"
- 39101 Tongs, 9"
- 39102 Tongs, 12"
- 39103 Spoon, ½ oz, 8"
- 39104 Spoon, 1 oz, 9½"
- 39105 Spoon, 2 oz, 10¾"



## Bamboo Knot Picks

- Eco-friendly picks enhance presentations from tabletop to buffet
- 100 per poly bag

BAMK45 4½" long





## Brickhouse Collection™ Serving Ware

- Stainless steel with brick pattern texture, these pieces are perfect for shareable sides, entrees, and beverages
- Easy to clean, dishwasher safe
- Bags and liners for convenient clean-up are available for pails and platters (sold separately)



### Ramekins

GRSS1	2½" dia x 1", 1½ oz
GRSS2	2¼" dia x 1¼", 2½ oz
GRSS3	2¾" dia x 1¼", 3 oz

### Fry Cups

GTSS28	Slanted Round, 3¼" dia x 4½", 9½ oz
GTSS375	Slanted Round, 3¼" dia x 4¾", 10 oz
GTSS31	Round, 3½" dia x 3½", 13 oz
GTSS4	Tapered Square, 3⅞" x 3⅞" x 3⅞", 20 oz
GTSS45	Round, 4" dia x 4½", 23 oz

### Round Pails w/Handle

GTSS33	3" dia x 3¼", 9 oz
GTSS44	4" dia x 3¾", 16½ oz
GTSS87	8" dia x 7", 1¼ gal

### Platters

GPSS8	Round, 8½" dia x 1⅝"
GPSS10	Round, 10½" dia x 1⅝"
GPSS90	Rectangular, 9½" x 6½" x 1½"
GPSS120	Rectangular, 12" x 9" x 1⅝"
GPSS96	Oval, 9½" x 6" x 2"
GPSS129	Oval, 12" x 9" x 1⅝"

### Rectangular Flatware Caddy

GPSSCADDY	10¾" x 8¾" x 4¾"
-----------	------------------



## Gastronorm Wood Crates

- Create a farm-fresh feel with gastro-sized wooden crates
- Perfect for buffet, display, or table top



CRATE13	Third Size, 12¾" x 7" x 2¾", Acacia Wood
CRATE13BK	Third Size, 12¾" x 7" x 2¾", Black Painted Wood
CRATE14	Fourth Size, 10⅝" x 6½" x 2¾", Acacia Wood
CRATE14BK	Fourth Size, 10⅝" x 6½" x 2¾", Black Painted Wood



## Cooler Cart

- Hinged lid opens on both sides for easy access
- Features stainless steel bottle opener, drain plug and removable cap catcher
- 3" locking casters

CC-65B 65 qt

## Brickhouse Collection™ Beverage Tub Set

- Stainless steel construction with brick pattern texture
- Includes 12¾ gallon Beverage Tub, Black Metal Stand, and 23¾" x 12¾" Condensation Tray



GTSS2313N 27½" w x 15" d x 32" h w/Stand



# BUFFET & CATERING



## Settlement Bistro™ Dinnerware

- Transport guests to a popular neighborhood café with this European-inspired melamine dinnerware
- Blend the lines of classic and contemporary
- Commercial dishwasher safe

Available in White with Black (-W/BK) or Cobalt Blue (-W/CB) Trim

CS-800	Bread Plate, 8"
CS-900	Round Plate, 9"
CS-1100	Round Plate, 11"
OP-960	Oval Plate, 9" x 6¼"
OP-1291	Oval Coupe Plate, 12¼" x 9"
CS-1280	Rectangular Platter, 11¾" x 7¾"
B-60	Shallow Bowl, 6 oz, 5¾" x 5¼"
B-100	Shallow Bowl, 10 oz, 7" x 6¾"
B-30	Small Round Side Dish Bowl, 3 oz, 3¾"
B-50	Small Round Side Dish Bowl, 4½ oz, 5"
B-140	Round Salad, Soup Bowl, 14 oz, 5½"
B-110	Salad/Pasta Bowl, 10 oz, 9"
B-220	Salad/Pasta Bowl, 24 oz, 11"



Available in Manilla (MA), American White (AW) or Black (BK)

BF-710	Round Plate, 7"
OP-1080	Oval Coupe Platter, 10" x 7¾"
OP-1300	Oval Coupe Platter, 12" x 9½"
OP-1411	Oval Coupe Platter, 14" x 10½"
B-46	Bowl, 1.7 qt, 9"
B-453	Bowl, 4½ oz, 4½"
B-44	Bowl, 10 oz, 4¾"
B-524	Bowl, 16 oz, 5¼"



## Stainless Steel Deli Pan

- Smooth, fully welded hemmed edge is easy to clean
- Each pan has two fold-down handles for carrying and compact space storage
- Great for both hot and cold food presentation

SW0915 6"w x 15"l x 2"d



Onyx

White Shadow



Sequoia



## Melamine Serving Boards

- The contemporary look of natural materials with the convenience of melamine make these boards perfect for any presentation
- Patterns: Onyx Series (N), Sequoia Series (S) or White Shadow Series (W)

SB514	14¾" x 8¾"
SB520	20¾" x 6¼"

With Handle

SB608	8½" x 7"
SB612	12½" x 5½"



## Frozen Beverage Machines

- Pre-cooling in the hopper means these models are approved for dairy; varying the menu with yummy options like shakes, smoothies, fruit juices, coffees, cappuccinos, margaritas, daiquiris and tea slush beverages
- Automatic consistency control allows serving a wide variety of beverages at the desired thickness
- Analog control system automatically regulates and maintains consistent product quality
- Floor standing model comes on convenient locking caster wheels
- The hopper agitator will stir product throughout the day, saving time and ensuring an even cool in the hopper
- Air-cooled



6650



6455H

	L x D x H	Hoppers	Volts	Flavors	8 oz Servings/hr
<b>Countertop</b>					
6650	15.2" x 27.1" x 31.7"	(1) 15.85 qt	110-120	1	120
6455H	18.8" x 25.7" x 32.7"	(2) 8.5 qt	115-120	2	140
6690H	17.9" x 26" x 33"	(1) 26.4 qt	208-230	1	236
6695H	21" x 25.7" x 38.3"	(2) 15.9 qt	208-230	2	338
<b>Floor</b>					
6795H	21.8" x 25.8" x 57.8"	(2) 15.9 qt	208-230	2	465



OASIS2

eurolib

### Frozen Drink Machines

- 2½ gal bowl
- Simple-to-use dispensing system
- Forced air-cooled compressor
- LED cover
- Stainless steel and plastic construction for chassis and panels provides strength for heavy use
- Disassemble and assemble the tank without tools

OASIS1	1 Tank, 10¾" w x 20¾" d x 33" h
OASIS2	2 Tanks, 16" w x 21" d x 33" h
OASIS3	3 Tanks, 24" w x 21" d x 33" h

## Juice Dispensers

- Fully hermetically sealed motor compressor
- Motor with automatic re-starter
- Forced air condenser
- Automatic thermostat
- Stainless steel body with clear polycarbonate bowls and lids
- 3 gallon bowls
- S/S tap and paddle system to avoid froth and oxidation
- 16½" d x 23½" h
- 110V (220V also available)

eurolib

CD1J	1 Bowl, ½ hp, 8¼" w
CD2J	2 Bowls, ½ hp, 15¼" w
CD3J	3 Bowls, ¼ hp, 23¼" w
CD4J	4 Bowls, 2 x ¼ hp, 31" w



CD2J



OFS30

## Granita Dispensers

- Lighted top panel to illuminate products
- Clear and durable polycarbonate containers
- Stainless steel cooling cylinder, frame, and front panel
- Continuous agitator stirs product and keeps it fresh
- 18½" d x 33¼" h
- 115V
- 1 year limited parts and labor warranty with an additional 4 years on the compressor

Omega

By Legacy



OFS20	(2) 3 Gallon Bowls, ½ hp, 15" w
OFS30	(3) 3 Gallon Bowls, ½ hp, 24" w

# BEVERAGE SERVICE

## Crathco® Frozen Beverage Dispensers

- Serve frozen smoothies, cappuccinos or lattes, granitas, fruit juices, lemonades, or cocktails
- Freezing cylinder keeps product available - no need to wait for product to re-freeze
- Patented FlavorLight™ illuminates the frozen product with your choice of eye catching back-lit signs
- Air-cooled
- 29"d, 120V
- 2 year parts & 1 year labor warranty

- 3311 Single, 1½ Gallon Frozen, 5 Gallon Storage, 13"w x 28½"h  
 3312 Double, 1½ Gallon Frozen, 2¼ Gallon Storage Per Side, 18½"w x 26¾"h



3312

3311



## GRINDMASTER



D35-3

D25-3

Models shown have plastic panels and drip tray.



## Crathco® Classic Bubblers™ Premix Cold Beverage Dispensers

- 5 gallon bowl has measuring marks
- Full beverage cooling to the dispense point, and right down to the last drink, with cup height up to 8¼"
- Two-piece, stainless steel dripless dispense valve
- Stainless steel side panels and drip tray
- Strong, polycarbonate bowl and cover
- Unique evaporator and high efficiency pump cools faster and more efficiently for quick start-up
- Includes spray and agitation circulation options
- 15"d x 27¼"h
- 120V
- 2 year parts & 1 year labor warranty

- D25-3 (2) 5 Gallon Bowls, 17½"w  
 D35-3 (3) 5 Gallon Bowls, 25½"w



## Stainless Steel Iced Tea Dispensers

- Stainless steel construction and faucet connection
- 3 gallon capacity
- Completely passivated inside and out to preserve flavor
- Fits most competitors' brewers
- Tall faucet for ease of use
- No liner required
- 22" x 6" x 13½"
- 90 day warranty

## GRINDMASTER

- GTD3-FOT Tomlinson® front valve  
 GTD3-TP Tomlinson® front valve with pinch tube  
 GTD3-FOT





**FOCUS**  
FOODSERVICE  
A CROWN BRANDS COMPANY



**BEVERAGE SERVICE**

**Cold Beverage Dispensers**

- Hollow stainless steel ice tube to keep beverages cool
- Removable drip tray
- Large 8.5 quart (8 liter) capacity per server

KPW9500 Single, 14<sup>1</sup>/<sub>4</sub>" x 10<sup>5</sup>/<sub>16</sub>" x 1<sup>3</sup>/<sub>4</sub>"  
 KPW9502 Double, 21<sup>1</sup>/<sub>2</sub>" x 14<sup>1</sup>/<sub>4</sub>" x 1<sup>3</sup>/<sub>4</sub>"



**Cold Beverage Dispensers**

- Brushed stainless steel base with BPA free Tritan™ reservoir
- Stainless steel removable infuser and center ice core (do not freeze core)

2<sup>1</sup>/<sub>2</sub> Gallon  
 75 10<sup>3</sup>/<sub>4</sub>" x 11<sup>1</sup>/<sub>2</sub>" x 19<sup>1</sup>/<sub>2</sub>"  
 5 Gallon  
 85 12<sup>1</sup>/<sub>4</sub>" x 13<sup>1</sup>/<sub>4</sub>" x 24<sup>1</sup>/<sub>2</sub>"



**Glass Beverage Dispensers**

- Decorative chrome-plated faucet
- Includes chalkboard necklace for attractive, easy labeling
- Dishwasher safe



Beehive™ - 2<sup>1</sup>/<sub>2</sub> Gallon  
 BDG1000 9" x 10<sup>3</sup>/<sub>4</sub>" x 14<sup>1</sup>/<sub>2</sub>", w/Ice Core & Infuser

Rustic Country™ - 2<sup>1</sup>/<sub>2</sub> Gallon  
 BDG2000 8<sup>1</sup>/<sub>4</sub>" x 10<sup>1</sup>/<sub>2</sub>" x 14" BDG2000

Mason Jar - 2 Gallon  
 BDG3000 7<sup>3</sup>/<sub>4</sub>" x 10<sup>1</sup>/<sub>4</sub>" x 12<sup>1</sup>/<sub>2</sub>", w/Ice Core & Infuser



**Upscale Beverage Dispenser**

- Brushed stainless steel double wall base with BPA-free Tritan™ reservoir
- Includes removable stainless steel infuser & ice core

1<sup>1</sup>/<sub>4</sub> Gallon  
 7515 8<sup>1</sup>/<sub>4</sub>" x 9" x 17<sup>3</sup>/<sub>4</sub>"



# BEVERAGE SERVICE

## Mobile Cup Dispensing Cart

- Stainless steel cabinet with 4 SLR-2L cup dispensers
- ABS cup dispensers hold 8 oz to 44 oz cups
- Recessed handles and removable bumper guards make transport easy
- 4 swivel casters with locks



MCDC-SLR4X1 12"w x 33"d x 35"h  
 MCDC-SLR2X2 17"w x 17"d x 35"h  
 MCDC-SLR4X2 17½"w x 33"d x 35"h

MCDC-SLR2X2



## Countertop Cup, Lid, Straw & Condiment Organizer

- Polystyrene construction
- 8 compartments to hold cups, lids, condiments, straws or stirrers
- Includes 1 SLR-2S cup dispenser for use with 3" to 4½" dia cups

SLR-SCL-1BT 9½"w x 18½"d x 14¼"h

## Cup, Lid & Straw Organizers

- Towers dispense 6 oz to 44 oz paper, plastic or foam cups with rim diameters between 2½"-4¾"
- Durable polystyrene or reinforced wire welded construction

### Vertical Polystyrene, Angled, NSF

LID-3BT 3 Sections, 5¼"w x 17"d x 16½"h  
 LID-4BT 4 Sections, 5¼"w x 20¾"d x 19½"h  
 LID-5BT 5 Sections, 5¼"w x 24½"d x 23"h

### Horizontal Wire

WR-3 3 Sections, 14½"w x 5"d x 8½"h  
 WR-4 4 Sections, 18½"w x 5"d x 8½"h  
 WR-5 5 Sections, 23"w x 5"d x 8½"h



LID-3BT

WR-5

## Countertop Boxed Cone Dispenser

- For use with all sizes of cone boxes up to 6" x 6"
- This cone dispenser can be used in either a countertop or wall-mount application
- Unit includes interchangeable baffle plates and collar adapters to ensure compatibility with all manufacturers' boxed cone sizes
- A hinged door closes when not in use to prolong cone freshness
- A lower crumb tray is included to allow for simple and fast clean-up

BCDS-BFL 9"w x 11¼"d x 15½"h



## Portion Cup/Lid Organizer

- Polystyrene construction
- Can be placed on the countertop or mounted to any vertical surface utilizing the rear facing key holes
- Accommodates portion cups or lids up to 3" rim diameter

CTCO-4BT 4 Compartments, 13¼"w x 3½"d x 9½"h



## Revolving Cup & Lid Organizers

- Black polystyrene construction
- 4 compartments

RCLO-SM-4BT Fits Portion Cups & Lids up to 3" dia, 7" sq x 13¼"h  
 RCLO-LG-4BT Fits Cups & Lids up to 4¼" dia, 9½" sq x 18¼"h



RCLO-SM-4BT

## Cup Holder/Organizer

- Countertop ABS plastic organizer
- 4 compartments hold cups, plastic bottles, thermoses and mugs
- Accommodates containers with 3½" maximum bottom diameter

PCH-4B 20"w x 5"d x 5"h





## Stainless Steel Pull-Type Cup Dispensers

- Accommodates cups with rim diameters from 2<sup>7</sup>/<sub>32</sub>" to 4<sup>7</sup>/<sub>8</sub>"
- Patented adjustable collar easily conforms to each cup size, ensuring optimal dispensing without damaging cups
- Counter and surface mount dispensers can be mounted in horizontal, vertical or 45° position
- Pull-type dispenser is top-loaded and gravity fed
- Dispensers have different springs for each type of application
- Available for foam, paper or plastic cups

- C3200P Series 6-10 oz Cup Size  
 C3400P Series 12-24 oz Cup Size  
 C3500P Series 32-46 oz Cup Size



BEVERAGE SERVICE



## Bulk Straw Dispensers

- High capacity straw organization
- Removable lid and tray for easy cleaning; dishwasher safe
- 10"w x 8"h



- ST250 Single-Sided, Holds 250 Straws, 4<sup>1</sup>/<sub>4</sub>"d  
 ST500 Double-Sided, Holds 500 Straws, 7<sup>7</sup>/<sub>8</sub>"d



## EZ-Fit® Cup Dispenser Cabinets

- One-size-fits-all cup dispenser inserts in a black polystyrene cabinet
- Fingerprint resistant for low maintenance
- Available with metal finish or black trim rings (add BK)
- 7<sup>3</sup>/<sub>4</sub>"w x 23<sup>3</sup>/<sub>4</sub>"d



C2902BK

C2901

- C2901 1 Insert, 7<sup>3</sup>/<sub>4</sub>"h  
 C2902 2 Inserts, 15"h  
 C2903 3 Inserts, 22<sup>3</sup>/<sub>8</sub>"h



## Lid Towers

- Wall mount
- Stainless steel
- 5<sup>1</sup>/<sub>2</sub>"w x 13"d
- 23<sup>1</sup>/<sub>2</sub>" tube

- L3500 Holds 32-46 oz Lids  
 L3502 Double Stack, Holds 24-46 oz Lids



L3500

L3502



## One-Size-Fits-All EZ-Fit® Cup Dispenser

- Patented EZ-Fit® design fits any size of disposable cup
- Gasket design works with paper, plastic and foam beverage cups
- Includes 4 pre-cut gaskets to accommodate 8-46 oz beverage cups, with rim diameters ranging from 2<sup>7</sup>/<sub>8</sub>" to 4<sup>3</sup>/<sub>4</sub>"
- Mount vertically or horizontally
- High-impact plastic construction
- Counter hole diameter 5<sup>3</sup>/<sub>4</sub>"



- C2410C In-Counter Mount, 23<sup>1</sup>/<sub>4</sub>" Tube





## Venue® In-Counter Napkin Dispenser

- Control face provides one-at-a-time dispensing
- Holds over 750 napkins
- Clear face plate with stainless steel trim
- 8<sup>13</sup>/<sub>16</sub>"l x 7<sup>1</sup>/<sub>4</sub>"w x 20"h

H2005CLSC



## In-Counter Cup Dispenser

- Durable stainless steel
- Easily adjusts to a wide range of cup diameters
- One-at-a-time dispensing of paper, plastic and foam cups



Counter Hole Cut-Out

C6200C	4 <sup>19</sup> / <sub>100</sub> "
C6400C	4 <sup>69</sup> / <sub>100</sub> "
C6500C	5 <sup>1</sup> / <sub>3</sub> "

## Adjustable Lid Organizers

- Lid organizers are 22-gauge stainless steel
- Can be placed on countertop or wall mounted
- Each compartment is adjustable to adapt to the lid size
- Comes with straw caddy (L1035) that can be attached to either side of the dispenser
- Anti-slip feet ensure that unit will stay in place during countertop use
- Stirrer & straw caddy are high impact plastic



L1014	3 Stacks, 17 <sup>1</sup> / <sub>8</sub> "w x 5 <sup>1</sup> / <sub>8</sub> "d x 6 <sup>1</sup> / <sub>2</sub> "h
L1022	5 Stacks, 25 <sup>1</sup> / <sub>4</sub> "w x 5 <sup>1</sup> / <sub>8</sub> "d x 6 <sup>1</sup> / <sub>2</sub> "h



## Venue® Tabletop Napkin Dispenser

- Napkin dispensing that combines attractive design with versatility for any venue
- Transparent design makes monitoring napkin levels easier
- Advertising insert space for in-house promotions
- Push plate allows for smooth, precise one-at-a-time dispensing
- Holds 200 fullfold napkins
- Black Pearl



H4005TBK 7<sup>1</sup>/<sub>2</sub>"w x 6<sup>1</sup>/<sub>8</sub>"d x 6<sup>1</sup>/<sub>4</sub>"h



## Venue® Napkin Dispenser

- Impact resistant plastic
- One-at-a-time dispensing
- Holds 450 fullfold napkins
- Translucent Black Pearl
- 8"w x 13"d x 17<sup>3</sup>/<sub>8</sub>"h



H5005STBK







## Super Auto Espresso Machines

- Make unlimited customized drinks with easy, touch screen operation
- Automated steam and foaming wand
- 2 bean hoppers with 3.75 and 2.6 lb bean capacity
- 2 precision grinders with 64 mm and 80 mm Mahlkonig burrs
- 1.66 gal capacity per brewer
- 240V
- 24"d x 32"h



	Capacity	Width
ACE	240 Cups/hr, 2-Step Brewer	18"
ST Duo	400 Cups/hr, 2-Step w/Dual Brewers	24"

ACE



## UNIC

### Pony Pod Super Auto Espresso Machine

- Stainless steel panels and welded steel framework
- Fully programmable coffee volume buttons
- Automated daily cleaning
- Hot water dispenser with flow regulation
- Automatic refill and cup warmer
- 120V
- 14"w x 23"d x 26"h



Pony 2 120 Cups/hr, 2 Heads, 1.66 gal Capacity



Twin MIRA

### Mira Traditional Espresso Makers

- Stainless steel panels and welded steel framework
- Fully programmable coffee volume buttons
- Automated daily cleaning
- Hot water dispenser with flow regulation
- Automatic refill and cup warmer
- Unlimited steam boiler
- 23"d x 23"h



## UNIC

	Capacity	Width	Volts
MIRA	120 Cups/hr, 1 Head, 1.66 gal	14"	120
Twin MIRA	240 Cups/hr, 2 Head, 2.6 gal	25"	230



PBC-2A

### PrecisionBrew™ Air-Heated Shuttle® Brewers

## GRINDMASTER

- Single and twin virtual sight glass models
- Brews into 1.5 gallon air-heated shuttles (not included)
- 3 independent brew volumes
- 3.2 gallon heating tanks
- 240V
- 25.75"d x 30.88"h



PBC-1A	Single Brewer, 9.13"w
PBC-2A	Twin Brewer, 18.13"w

## Sure Tamp™ Espresso Machines

A profitable espresso beverage program that delights your customers requires equipment that is embraced by staff, safe to use, intuitive, consistent and easily maintained.

- Milk Texturing Fusion™ delivers rich, creamy milk
- Large 7" touchscreen for easy-to-use Build-A-Drink™ control console
- Display guides the operator step-by-step through proper cleaning techniques with Picture Prompted Cleaning™
- Machine self-monitors and provides status alerts with on-screen diagnostics
- BUNNlink™ enables cloud-based service support
- 208V/20.4 amps, 4300 total watts
- 30.06"h x 12.4"w x 25.28"d



43400.0024  
Sure Tamp™ Steam, 2-Step



*Intellisteam™ wand is engineered for the barista but designed for staff with varying levels of experience*



Self Serve or Crew Serve



Barista Created

43400.0500  
Sure Tamp™ Auto, 1-Step



*Milk Texturing Fusion™ technology produces effortless rich and creamy milk*



## Jumbo Airtop

- Brushed stainless steel body with unbreakable stainless steel liner
- Lever-top
- Complete with color-coded hang tags & content stickers for quick at-a-glance content identification

JAL-37 1 Gallon



## Thermal Gravity Dispenser

- Break-resistant vacuum insulated S/S liner
- Built-in sight glass and brew-through lid
- Drip tray and base are removable for use with satellite brewers
- Manual Dial Time indicator to track beverage holding times

TGD-15GT 1½ Gallon





FCMCS100



FCMAA100



### Contemporary Stainless Steel Coffeemakers

- Non-drip spigot
- Stay-cool phenolic handles and knob
- Twist-to-secure cover
- Interior water level markings
- Cup capacity is based on 5 oz cup
- 2 year limited warranty
- 110/120V



FCMCS060 60 Cup Capacity  
FCMCS100 100 Cup Capacity

### Aluminum Coffeemakers

- Automatically brew perfect coffee and hold it at the ideal serving temperature
- Non-drip spigot
- Stay-cool phenolic handles and knob
- Signal light that indicates when coffee is brewed
- 3 prong grounded plug
- Cup capacity is based on 5 oz cup
- 2 year warranty
- 110/120V

FCMLA030 30 Cup Capacity  
FCMAA055 55 Cup Capacity  
FCMAA100 100 Cup Capacity

### Insulated Beverage Dispensers

- Stainless steel interior and exterior
- Drop handle for easy carrying, pivots out of the way while in use
- Screw-on lid eliminates spills
- Foam insulated to maintain desired temperature longer
- Locking lever feature allows for quicker, hands-free dispensing
- Legs allow for larger capacity cups
- Legs fold down for compact storage

BD95SS 10 qt (9.5L)  
BD14SS 14.8 qt (14L)



# TABLETOP

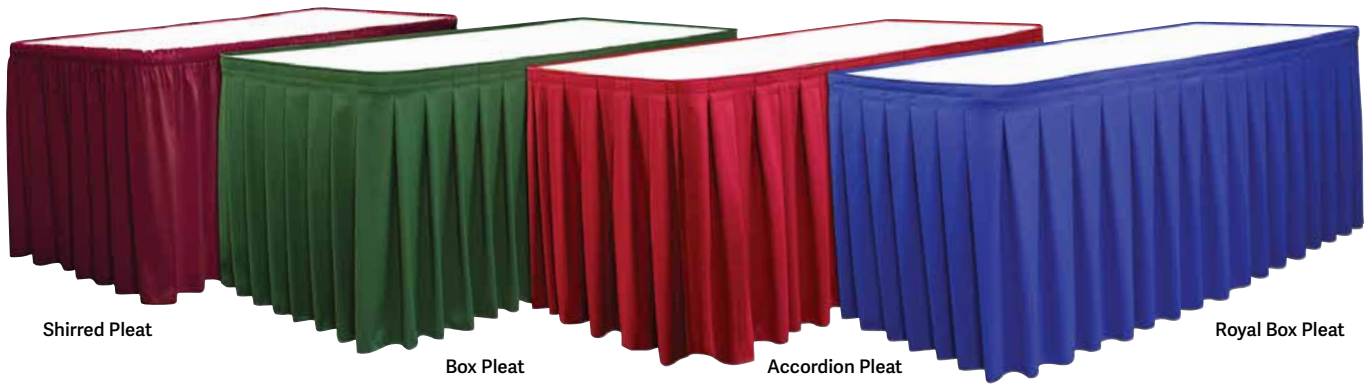

Shirred Pleat

Box Pleat

Accordion Pleat

Royal Box Pleat

## Table Skirting

- Complete line of fabrics in a virtual rainbow of colors
- Available in 100% polyester Twill fabric that is durable and wrinkle-free
- Other fabrics and colors available for special order (minimum quantity applies)
- Flame retardant

### Standard Skirt Sizes

- 13' x 29" h - For 6' & 8' Tables on 3 Sides
- 17'6" x 29" h - For 6' x 30" Tables on 4 Sides
- 21'6" x 29" h - For 8' x 30" Tables on 4 Sides

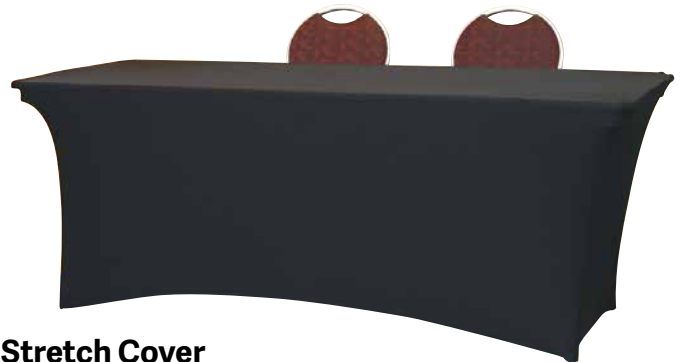

## Stretch Cover

- Made from a highly stretchable fabric that form fits to the table and eliminates any wrinkles

## Skirt Clips



Omni Clip  
w/Valance Tab



1/2" Clip  
w/Valance Tab



Velcro Clip



Lifetime  
Clip



3/4" Clip  
w/Valance Tab

## Beverage Dispenser, Bus Tub, Tray, Tray Stand & Trash Can Covers

- 100% polyester fabric
- 4 styles and a rainbow of colors (see swatches)
- NFPA 701 & CA Flame Retardant
- Machine washable
- Made in the USA



## Cart Skirting

- Elegant skirting hides slide racks, reels, unsightly wires and power strips
- 100% polyester fabric in 4 styles and a rainbow of colors
- NFPA 701 & CA Flame Retardant
- Machine washable
- Made in the USA

## Mobile Caddy & Skirt Hanger

- Stainless steel

## Round Table Covers & Toppers

- 100% polyester, a rainbow of colors and sizes





## GuestChecks™

- Improve customer satisfaction and save time with more efficient and effective service
- Less expensive than scratch pads
- Green tint
- 3½" x 6¾"

Jackson & Associates  
Presents...



- 1 Part**
- G3616** 16 Line, Single Copy Paper (Bond), 100 Checks/Book, 50 bks/cs
- G3632** 15 Line, Single Copy Cardboard, 50 Checks/Book, 50 bks/cs
- 2 Part**
- G6000** 17 Line, Carbon, 50 Sets/Book, 50 bks/cs
- G7000** 17 line, Carbonless, 50 Sets/Book, 50 bks/cs
- 1 Part - White tint - 3½" x 5½"**
- 3516SP** 13 Line, Single Copy Paper, 100 Checks/Book, 100 bks/cs

## Liner Tissue & Take-Away Cones

- Crafted with 100% food-safe materials
- Add flair to your menu presentation
- Take-away cones feature perforated back that easily folds closed to keep food fresh and hot



- 12" x 12" Liner Tissue, 1000/cs**
- 4-TY1200** New York Tabloid Print
- 4-TN1000** London Royal Times Print
- 4-TG1080** Sports Wrap Print
- 4-TE1050** Cuban 50's Print
- 4-TF1600** La Vue Print

4-81844 Basket shown with 4-TA-500 Cone

- Take-Away Cones, 500/cs**
- 4-TA-500** White, 11" x 4½"
- 4-TA-540** Brown, 11" x 4½"
- 4-TAJ-50** Brown, 9" x 3¾"



TABLETOP



## Treadlite™ Trays

- Fiberglass reinforced polyester lightweight tray has a molded in non-skid surface
- Non-skid surface ensures items stay in place during service
- Reinforced edges provide superior strength and protection
- Stacking lugs enhance air circulation for quick, effective drying and perfect stacking
- Available in Black Satin (110) and Tavern Tan (138)

**1400TL** 14" dia  
**1600TL** 16" dia

**CAMBRO**  
TRUSTED FOR GENERATIONS™



## Serving Cones & Baskets

- Stainless steel, 4-32800 is Black powder-coated iron

- 4-32800** Round Fry Cone, 7" dia x 7"
- 4-81844** Square Fry Cone, 5¼" x 2½"
- 4-81860** Mini Square Fry Basket, 4" x 3¼"
- 4-835809** Rectangular Grid Basket, 9" x 7"



## Tray Stands

- 774** Standard, Chrome
- 775** Deluxe, Chrome
- 772** 38" Wood
- 773** 32" Wood

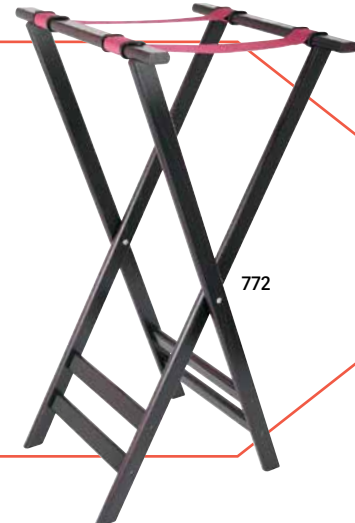

**ROYAL INDUSTRIES**  
Foodservice & Hospitality Products

# TABLETOP



## Stackable Gravy Boats

- 18/8 stainless steel with brushed exterior

9803	3 oz
9805	5 oz
9808	8 oz
9812	12 oz



DCFP-4S



DCSC-3S



DCSP-3C



DCCR-3C

## Mini Cookware

- Tri-ply construction works on all heat sources
- 18/8 stainless steel cookware surface for superior cooking performance
- Aluminum core provides efficient heat distribution
- Add suffix for stainless steel (S) or copper (C) exterior

DCSC-3	Saucier, 5 oz
DCSP-3	Sauce Pan, 11 oz
DCCR-3	Casserole, 15 oz
DCFP-4	Fry Pan, 4" dia



## Serving Platter & Underliner Sets

- Pre-seasoned skillets with wood underliners
- 10" x 7"

1024974	With 5" Handle
1024975	Without Handle



By Crown Brands





SK-11-B



**TABLETOP**



FPS-12-B



SP-12-BC

**Coal Bakeware**

- Perfect for cooking and serving
- Attractive black matte finish
- Oven safe to 450°F
- 3-year chip warranty



CAS-60-B

CAS-6-B

**Casserole Dishes**

- CAS-6-B 16 oz, 6" with Handles
- CAS-40-B 16 oz, 4¾" with Handles & Lid
- CAS-60-B 24 oz, 6" with Handles & Lid

**Crème Brûlée**

- OB-55-B 8 oz, 5¼"

**Serving Skillets**

- SK-8-B 12 oz, 8¾"
- SK-11-B 24 oz, 11¾"

**Soup Crock**

- OSC-55-B 10 oz, 5"
- SP-12-BC 12 oz, 4½"

**Fry Pan Skillets**

- FPS-12-B 10¾"
- FPS-18-B 11¾"
- FPS-24-B 13¾"

**Oval Welsh Rarebit**

- WRO-8-BC 8 oz, 8½"



OB-55-B



WRO-8-BC



## Saturn™ Holloware

- 18/10 stainless steel in bright finish for hotel or restaurant use
- Saturn's classic coffee pot outline features a gooseneck spout for ease and accuracy in pouring
- AW = argon welded

9-201LD	Sugar Bowl Lid for 8 oz
9-201BX	Sugar Bowl w/o Lid, 8 oz
9-201LBX	Sugar Bowl w/Lid, 8 oz
9-202BX	Creamer, 8 oz
9-214	Creamer, 12 oz
9-212	Covered Server, 12 oz
9-236AW	Covered Tea Pot, 12 oz
9-237AW	Covered Tea Pot, 21 oz
9-231AW	Coffee Server, 12 oz
9-232AW	Covered Coffee Server, 21 oz
9-235AW	Covered Coffee Server, 70 oz
9-218G	Water Pitcher w/Ice Guard, 70 oz
9-218	Water Pitcher w/o Ice Guard, 70 oz



## Venus™ Holloware

- 18/10 mirror finish stainless steel
- Argon welded for heavy hotel banquet use

P-Z403LD	Sugar Bowl Lid for 8 oz
P-Z403	Sugar Bowl w/o Lid, 8 oz
P-Z403L	Sugar Bowl w/Lid, 8 oz
P-Z404	Creamer, 8 oz
P-WC391	Covered Server, 12 oz
P-T381	Tea Pot, 12 oz
P-C381	Coffee Server, 12 oz
P-C382	Coffee Server, 20 oz
P-XC384	Coffee Server w/o Base, 60 oz
P-XW389-G	Water Pitcher, 60 oz



Ready to learn more about these great products?  
**PLAY VIDEO** 



CHEF SPECIALTIES

### Professional Series

- Stainless steel grinding mechanisms
- Acrylic mills come filled with black pepper and salt
- Lifetime guarantee on grinding mechanisms

#### Pepper Mills

- 06350 6" Salem Pepper Mill, Ebony Finish
- 10150 10" Imperial Wood Pepper Mill, Walnut Finish
- 11880 11" Pueblo Wood Pepper Mill, Mocha Finish
- 12401 12" Prentiss S/S Pepper Mill, Brushed Finish
- 18100 18" Monarch Wood Pepper Mill, Walnut Finish

#### Shaker Sets

- 29910 4" Futura S/S Pepper Mill and Salt Mill Set, Brushed Finish
- 04100 4" Capstan Wood Pepper Mill and Salt Shaker Set, Walnut Finish
- 29190 5" Laurel Acrylic Pepper Mill and Salt Shaker Set
- 90055 5½" Burnished Pepper Mill and Salt Shaker Set, Dark Copper, Sturdy Metal Holder Included

#### Replacement Knob

- 36098 Replacement Top Knob for Professional Wood Pepper Mills



### CHEF SPECIALTIES

#### HomeCookin' Series

- Durable ceramic grinding mechanisms
- Adjustable from fine to coarse
- Come filled with black peppercorns and sea salt



### Flameless Lighting

Hollowick is proud to offer flameless candles that stand at the forefront of commercial LED lighting. Increasing demands by foodservice professionals for exceptional performance and lifelike ambience drives innovation and enhancement to the Hollowick Flameless line. The industry-leading flicker technology, battery life and warranties illustrate a firm commitment to improving customer service, product satisfaction and the overall guest experience.



Nexis® Flameless Rechargeable Set



LED Battery Tealights



Real Wax LED Flameless Pillar Candles



TABLETOP

# TABLETOP

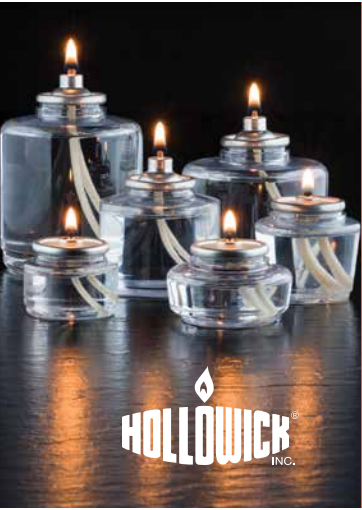

## Disposable Liquid Fuel Cells

Using Hollowick disposable fuel cells is the most convenient way to operate your lamps and is preferred by most users today. These fuel cells eliminate the wax mess and thermal shock glass breakage problems of solid wax candles. No maintenance or adjustments necessary. These fuel cells are safe to use, odorless, non-staining, and have true burn times. More items available; please contact your salesperson for details.

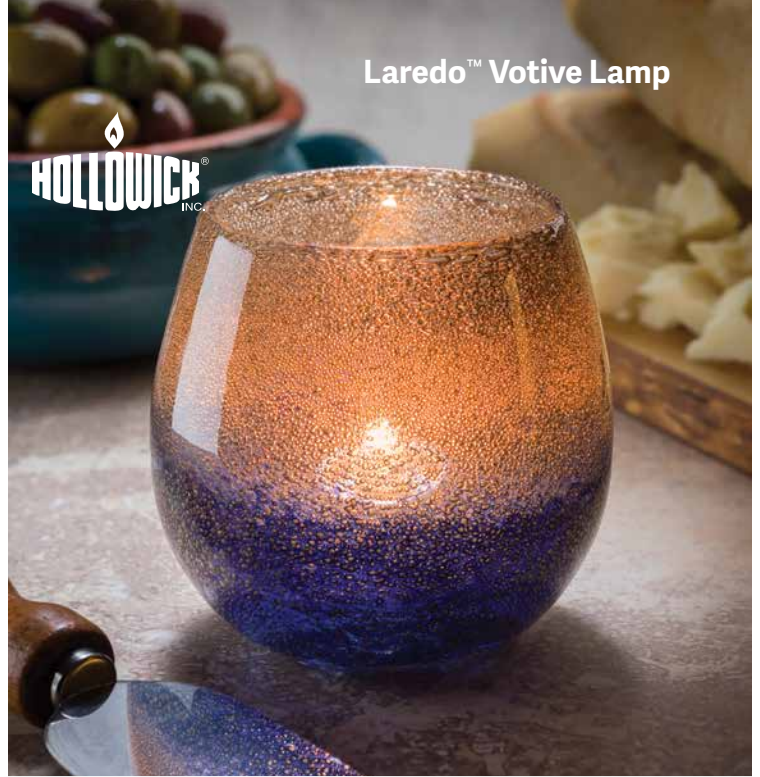

## Laredo™ Votive Lamp

Hollowick lamps are available in a wide variety of shapes and sizes. More items available. Please contact your salesperson for details.



## Sussex™ Tealight Lamp



## Monarch™ Votive Lamp



## Brady™ Modern Metal Frame

Shown with cylinder lamp (sold separately)



CaterLite™ Disposable Candle

## Select Wax® Solid Wax Candles

Hollowick's Select Wax® solid wax candles offer the finest quality and reliability in foodservice. Using a special wax blend designed to withstand foodservice storage and service conditions. Choose from a wide variety: everything from tealights and votives, to pillars and even birthday candles. More items available; please contact your salesperson for details.





## Luna™ Dinnerware

- Handcrafted, non-geometric shapes with organic flair
- Microwave & dishwasher safe
- Lead free porcelain
- Hand painted glaze finish
- Add suffix for color: Ash (AS), Midnight Blue (-MI) or Terracotta (-TA)

		Pk
LU-77	Square Plate, 7"	2 dz
LU-22	Square Plate, 10"	1 dz
LU-7	Plate, 7"	2 dz
LU-8	Plate, 9"	1 dz
LU-16	Plate, 10½"	1 dz
LU-21	Plate, 12"	1 dz
LU-12	Platter, 10" x 5½"	2 dz
LU-14	Platter, 12½" x 6½"	1 dz
LU-64	Rectangular Platter, 6" x 4"	3 dz
LU-133	Rectangular Platter, 13" x 6½"	1 dz
LU-18	Nappie Bowl, 5⅝", 14 oz	1 dz
LU-43	Bowl, 7 oz	2 dz
LU-3	Rim Bowl, 8½", 20 oz	1 dz
LU-2	Saucer, 5¾"	2 dz
LU-1	Cup, 9 oz	2 dz

Ash Glaze



Terracotta Glaze



**TABLETOP**

## Slope Dinnerware

- Bright white porcelain
- Available in squares and rectangles
- Perfect canvas for any culinary creation



		Pk
SP-5	Square Plate, 5"	3 dz
SP-6	Square Plate, 6"	3 dz
SP-7	Square Plate, 7"	3 dz
SP-8	Square Plate, 8"	2 dz
SP-9	Square Plate, 9"	2 dz
SP-10	Square Plate, 10"	1 dz
SP-20	Square Plate, 11¼"	1 dz
SP-21	Square Plate, 12"	1 dz
SP-12	Rectangular Platter, 10" x 5¼"	2 dz
SP-13	Rectangular Platter, 11½" x 6½"	1 dz
SP-14	Rectangular Platter, 13⅞" x 7"	1 dz
SP-50	Rectangular Platter, 14½" x 8¼"	1 dz
SP-15	Square Bowl, 7 oz, 3½"	3 dz
SP-66	Square Bowl, 16 oz, 6¼"	2 dz
SP-88	Square Bowl, 46 oz, 8"	2 dz
SP-2	Saucer, 6¼"	3 dz
SP-1	Tall Cup, 9 oz	3 dz



# TABLETOP



## Bristol™ Dinnerware

- Bright white porcelain
- Rolled edge
- Fully vitrified
- Microwave & dishwasher safe
- Lead free

		Pk
BL-6	Plate, 6¼"	3 dz
BL-7	Plate, 7"	3 dz
BL-88	Plate, 9"	2 dz
BL-16	Plate, 10½"	2 dz
BL-21	Plate, 12"	1 dz
BL-34	Platter, 9¼" x 6¾"	2 dz
BL-12	Platter, 10½" x 7½"	2 dz
BL-41	Platter, 13½" x 9¾"	1 dz
BL-2100	Fish Platter, 21"	1 dz
BL-11	Fruit Bowl, 6 oz, 5¼"	3 dz
BL-15	Fruit Bowl, 10½ oz, 6¾"	3 dz
BL-25	Soup Bowl, 10 oz, 7"	3 dz
BL-26	Soup Bowl, 16 oz, 8"	3 dz
BL-1200	Deep Pasta Bowl, 18 oz	1 dz
BL-120	Pasta Bowl 24 oz, 12½"	1 dz
BL-115	Pasta Bowl, 32 oz, 10½"	1 dz
BL-210	Stadium Bowl, 44 oz, 10½"	1 dz
BL-209	Stadium Bowl, 28 oz, 9"	1 dz
BL-2	Saucer, 6⅛"	3 dz
BL-1	Tall Cup, 12 oz	2 dz
BL-23	Stacking Cup, 9 oz	3 dz



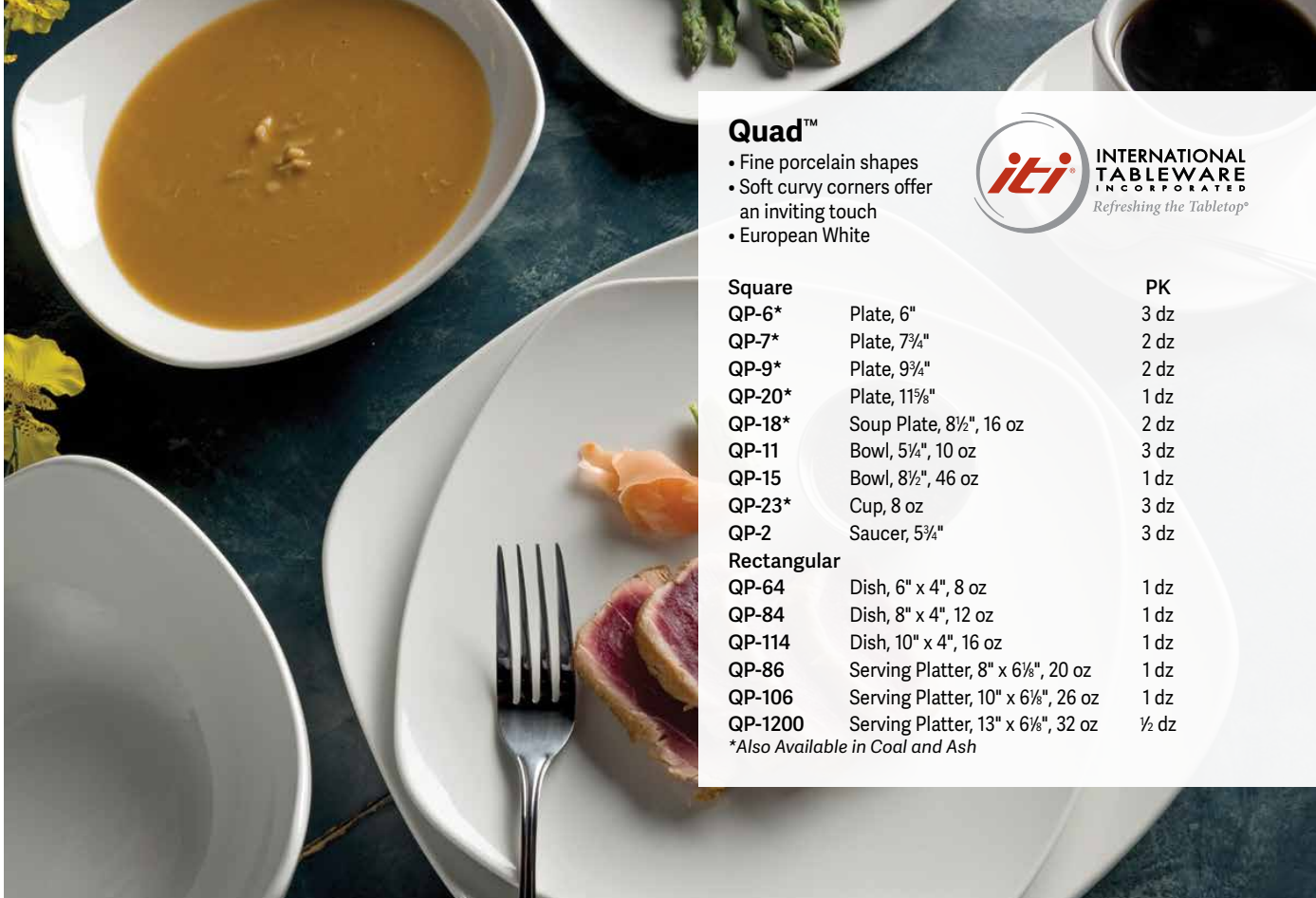

## Quad™

- Fine porcelain shapes
- Soft curvy corners offer an inviting touch
- European White



**INTERNATIONAL  
TABLEWARE  
INCORPORATED**  
*Refreshing the Tabletop®*

		PK
<b>Square</b>		
QP-6*	Plate, 6"	3 dz
QP-7*	Plate, 7 $\frac{3}{4}$ "	2 dz
QP-9*	Plate, 9 $\frac{3}{4}$ "	2 dz
QP-20*	Plate, 11 $\frac{5}{8}$ "	1 dz
QP-18*	Soup Plate, 8 $\frac{1}{2}$ ", 16 oz	2 dz
QP-11	Bowl, 5 $\frac{1}{4}$ ", 10 oz	3 dz
QP-15	Bowl, 8 $\frac{1}{2}$ ", 46 oz	1 dz
QP-23*	Cup, 8 oz	3 dz
QP-2	Saucer, 5 $\frac{3}{4}$ "	3 dz
<b>Rectangular</b>		
QP-64	Dish, 6" x 4", 8 oz	1 dz
QP-84	Dish, 8" x 4", 12 oz	1 dz
QP-114	Dish, 10" x 4", 16 oz	1 dz
QP-86	Serving Platter, 8" x 6 $\frac{1}{8}$ ", 20 oz	1 dz
QP-106	Serving Platter, 10" x 6 $\frac{1}{8}$ ", 26 oz	1 dz
QP-1200	Serving Platter, 13" x 6 $\frac{1}{8}$ ", 32 oz	$\frac{1}{2}$ dz

\*Also Available in Coal and Ash



**TABLETOP**



## Dresden™

- Woven lines embossed pattern
- Bright White porcelain

		PK
DR-6	Plate, 6 $\frac{1}{4}$ "	3 dz
DR-22	Plate, 8 $\frac{3}{8}$ "	2 dz
DR-16	Plate, 10 $\frac{3}{8}$ "	2 dz
DR-21	Plate, 11 $\frac{1}{4}$ "	1 dz
DRN-6	Plate, Narrow Rim, 6 $\frac{1}{4}$ "	3 dz
DRN-22	Plate, Narrow Rim, 8 $\frac{3}{8}$ "	2 dz
DRN-8	Plate, Narrow Rim, 9"	2 dz
DRN-16	Plate, Narrow Rim, 10 $\frac{3}{8}$ "	2 dz
DR-12	Platter, 10 $\frac{1}{8}$ " x 7"	1 dz
DR-14	Platter, 12 $\frac{1}{8}$ " x 8 $\frac{1}{2}$ "	1 dz
DR-51	Platter, 14 $\frac{1}{8}$ " x 9 $\frac{7}{8}$ "	1 dz
DR-10	Grapefruit Bowl, 7", 10 oz	2 dz
DR-11	Fruit Bowl, 4 $\frac{3}{8}$ ", 12 oz	3 dz
DR-15	Salad Bowl, 5 $\frac{1}{2}$ ", 18 oz	2 dz
DR-120	Pasta Bowl, 12 $\frac{1}{2}$ ", 24 oz	1 dz
DR-3	Deep Rim Bowl, 8 $\frac{3}{4}$ ", 10 oz	2 dz
DR-37	A.D. Cup, 4 oz	3 dz
DR-38	Saucer for A.D. Cup, 4 $\frac{3}{4}$ "	3 dz
DR-23	Stacking Cup, 9 oz	3 dz
DR-2	Saucer for Stacking Cup, 6 $\frac{1}{2}$ "	3 dz
DR-100	Creamer, 8 oz	1 dz
DR-101	S&P Shakers, 2" dia, 2 $\frac{5}{8}$ "h	1 dz sets
DR-225	Sugar Packet Holder, 3 $\frac{3}{8}$ " x 2 $\frac{3}{8}$ "	3 dz



## Brighton™

- Porcelain narrow rim
- European White



**INTERNATIONAL  
TABLEWARE  
INCORPORATED**  
*Refreshing the Tabletop®*

		PK
BR-7	Plate, 7 $\frac{1}{4}$ "	3 dz
BR-8	Plate, 9"	2 dz
BR-16	Plate, 10 $\frac{3}{8}$ "	2 dz
BR-12	Platter, 9 $\frac{3}{4}$ " x 7 $\frac{7}{16}$ "	2 dz
BR-13	Platter, 11 $\frac{1}{2}$ " x 9"	1 dz
BR-14	Platter, 13 $\frac{1}{4}$ " x 10"	1 dz
BR-11	Fruit Bowl, 4 $\frac{3}{4}$ oz	3 dz
87241	Toledo Mug, 8 $\frac{1}{2}$ oz	3 dz
BR-2	Saucer, 5 $\frac{1}{2}$ "	3 dz

Additional pieces available upon request

# TABLETOP

## Dover™

- Porcelain
- Rolled edge
- White



		PK
DO-7	Plate, 7½"	3 dz
DO-8	Plate, 9"	2 dz
DO-16	Plate, 10½"	1 dz
DO-83	WR Platter, 11½" x 8¼"	1 dz
DO-13	Coupe Platter, 11¾" x 8"	1 dz
DO-84	WR Platter, 12½" x 9"	1 dz
DO-4	Bouillon, 7 oz	3 dz
DO-11	Fruit Bowl, 4¾ oz	3 dz
DO-120	Pasta Bowl, 11⅞", 20 oz	1 dz
DO-3	Deep Soup Bowl, 9", 13 oz	3 dz
DO-1	Tall Cup, 7 oz	3 dz
DO-2	Saucer, 6"	3 dz



## Torino™

- Porcelain
- Coupe shape
- European White

		PK
TN-7*	Coupe Plate, 7"	3 dz
TN-9	Coupe Plate, 9"	2 dz
TN-16*	Coupe Plate, 10"	2 dz
TN-21*	Coupe Plate, 12"	1 dz
TN-306*	Deep Coupe Plate, 6"	3 dz
TN-307	Deep Coupe Plate, 7½"	3 dz
TN-309	Deep Coupe Plate, 9"	2 dz
TN-310	Deep Coupe Plate, 10"	1 dz
TN-55	Stacking Plate, 5"	3 dz
TN-77	Stacking Plate, 7¾"	3 dz
TN-88	Stacking Plate, 9"	1 dz
TN-100*	Stacking Plate, 10¼"	1 dz
TN-4	Sauce Dish, 3", 2 oz	4 dz
TN-107	Pasta Plate, 7⅞"	2 dz
TN-108	Pasta Plate, 8"	1 dz
TN-109	Pasta Plate, 8⅞"	2 dz
TN-110*	Pasta Plate, 10"	1 dz
TN-34	Coupe Platter, 9⅝" x 7½"	1 dz
TN-12	Coupe Platter, 10¼" x 8"	2 dz
TN-13	Coupe Platter, 11¾" x 8"	1 dz
TN-14	Coupe Platter, 13¼" x 9⅞"	1 dz
TN-51	Coupe Platter, 15½" x 11¼"	½ dz
TN-205	Ellipse Bowl, 5⅞", 10 oz	1 dz
TN-207*	Coupe Bowl, 6¾", 20 oz	1 dz
TN-208	Coupe Bowl, 8", 32 oz	1 dz
TN-210	Coupe Bowl, 10", 60 oz	1 dz
9696W	Stacking Mug, 12 oz	3 dz

\*Also Available in Coal and Ash





## Great Wall Dinnerware



- Bone White porcelain
- Glazed foot
- Microwave, oven and dishwasher safe

		PK
GW-5	Plate, 5½"	3 dz
GW-6	Plate, 6½"	3 dz
GW-7	Plate, 7¼"	3 dz
GW-8	Plate, 9"	2 dz
GW-9	Plate, 9¾"	2 dz
GW-16	Plate, 10½"	1 dz
GW-3	Soup Plate, 10 oz, 9"	2 dz
GW-12	Oval Platter, 10¼"	2 dz
GW-13	Oval Platter, 11½"	1 dz
GW-14	Oval Platter, 12½"	1 dz
GW-48	Stacking Bouillon, 12 oz, 4"	3 dz
GW-32	Fruit Bowl, 3½ oz, 4½"	3 dz
GW-V3	Soup Bowl, 4 oz, 3½"	4 dz
GW-105	Pasta Bowl, 16 oz, 10¼"	1 dz
GW-130	Pasta Bowl, 26 oz, 12"	1 dz
GW-36	Saucer, 4½"	3 dz
GW-2	Saucer, 5¾"	3 dz
GW-35	Cup, 3½ oz	3 dz
GW-1	Tall Cup, 7½ oz	3 dz
GW-56	Cappuccino Cup, 14 oz	3 dz
GW-TM8	Tierra Mug, 8 oz	3 dz

*Additional pieces available upon request*



**TABLETOP**



Jackson & Associates Presents...

**WORLD**<sup>®</sup>  
TABLEWARE

## Slate Dinnerware

- This Bright White china is perfect for dinner, appetizers or tapas
- Durable, porcelain body
- Special Order - Allow 2 weeks, freight additional

		PK
SL-10	Square Plate, 10⅝"	1 dz
SL-11	Square Fruit Bowl, 5", 5½ oz	3 dz
SL-12	Square Grapefruit, 7", 12 oz	2 dz
SL-2	Square Saucer, 5⅞" dia, fits SL-1	3 dz
SL-1	Tall Cup, 9 oz, Fits saucer SL-2	3 dz



## Grass Valley Collection

- The distinctive embossed "grass" rim organically frames your cuisine
- Adds a fresh look to your tabletop
- Versatile European styling
- 1 year chip warranty



## Opera Collection

Fits smartly into any application

- Bright White porcelain
- Rolled edge rim



## Alpine Collection

Crisp, clean and modern

- Alpine features fresh-white dishware for a crisp, clean tabletop
- Simple shapes with graceful wide rims
- Suitable for everything from a casual breakfast to an elegant dinner
- 5 different varieties of trim available
- 1 year chip warranty







### Orbit Collection

- True black porcelain provides a dramatic backdrop for all your presentations
- Trend setting curved coupe shape and extremely unique accessory items
- Strong bodies with thermal properties
- Super matte finish and still very scratch resistant



### Argyle & Catalina Collection

- Bright European white body
- Argyle features a traditional wide rim
- Catalina has a standard narrow rim
- Catalina is microwave and dishwasher safe, and lead free FDA approved



TABLETOP

### London Moonstone Collection

- London Moonstone is completely unique with a reactive glaze making each piece elegantly different
- Hand painted
- Dark matte finish
- Glazed foot and alumina body



# TABLETOP



## Jazz Dinnerware

- Break-resistant melamine
- Commercial dishwasher safe - top rack

		PK			PK
DM005J	WR Plate, 5½"	8 dz	DM209J	Platter, 9½" x 7¼"	4 dz
DM006J	WR Plate, 6½"	8 dz	DM212J	Platter, 12" x 9"	4 dz
DM007J	WR Plate, 7⅞"	6 dz	DM213J	Platter, 13½" x 10½"	3 dz
DM009J	WR Plate, 9¼"	4 dz	DM5044J	Salad Bowl, 4 oz, 4¾"	8 dz
DM010J	WR Plate, 10½"	4 dz	DM5608J	Salad Bowl, 8 oz, 6"	8 dz
DM012J	WR Plate, 11¾"	4 dz	DM5807J	Salad Bowl, 32 oz, 7½"	4 dz
			DM5811J	Pasta Bowl, 16 oz, 11¼"	3 dz



## Graham Dinnerware

- Serving and display
- Break-resistant melamine
- Commercial dishwasher safe - top rack



		PK			PK			PK
DM005H	WR Plate, 16 oz, 5½"	8 dz	DM5608H	Salad Bowl, 8 oz, 6"	8 dz	SD3216H	Square Plate, 16"	12 ea
DM006H	WR Plate, 6½"	8 dz	DM5807H	Salad Bowl, 32 oz, 7½"	4 dz	SD3314H	Tray, 13¾" x 9½"	24 ea
DM007H	WR Plate, 7⅞"	6 dz	DM5811H	Pasta Bowl, 16 oz, 11¼"	3 dz	SD3318H	Tray, 17½" x 6¾"	24 ea
DM009H	WR Plate, 9¼"	4 dz	SD2118H	Oval Platter, 18" x 13½"	12 ea	SD3324H	Rectangular Tray, 24" x 18"	24 ea
DM010H	WR Plate, 10½"	4 dz	SD2121H	Oval Platter, 21" x 15"	12 ea	SD5609H	Deep Bowl, 1 qt, 9" x 2½"	24 ea
DM012H	WR Plate, 11¾"	4 dz	SD3206H	Square Plate, 6"	48 ea	SD5612H	Deep Bowl, 2 qt, 12½" x 3"	24 ea
DM209H	Platter, 9½" x 7¼"	4 dz	SD3208H	Square Plate, 8"	48 ea	SD5613H	Deep Bowl, 3 qt, 13½" x 3¼"	24 ea
DM212H	Platter, 12" x 9"	4 dz	SD3210H	Square Plate, 10"	48 ea	SD5614H	Deep Bowl, 4 qt, 14" x 3¼"	12 ea
DM213H	Platter, 13½" x 10½"	3 dz	SD3212H	Square Plate, 12"	24 ea	SD6015H	Deep Bowl, 6 qt, 15" x 5"	12 ea
DM5044H	Salad Bowl, 4 oz, 4¾"	8 dz	SD3214H	Square Plate, 14"	12 ea	SD6018H	Deep Bowl, 10 qt, 18" x 6"	12 ea



## Urban Mill™ Dinnerware

- Premium melamine with a glazed surface
- Hand-made appearance in a rustic color and irregular shapes



B-8-UM	Irregular Bowl, 8 oz	PK
B-18-UM	Irregular Bowl, 16 oz	2 dz
B-22-UM	Irregular Bowl, 22 oz	1 dz
B-43-UM	Irregular Bowl, 28 oz	1 dz
B-42-UM	Irregular Bowl, 1.3 qt	1 dz
CS-10-UM	Irregular Round Coupe Plate, 10½"	1 dz
CS-117-UM	Irregular Rectangular Platter, 12" x 7½"	1 dz
CS-1412-UM	Irregular Rectangular Platter, 14" x 11½"	6 ea
CS-146-UM	Irregular Rectangular Platter, 14" x 5½"	12 ea
CS-7-UM	Irregular Round Coupe Plate, 7"	1 dz
CS-9-UM	Irregular Round Coupe Plate, 9"	1 dz



TABLETOP

CAC®



### Phoenix Flatware

- 18/0 stainless steel
- Heavy weight
- Packed 1 dz

3001-01	Teaspoon
3001-04	Bouillon Spoon
3001-02	Iced Tea Spoon
3001-09	Demitasse Spoon
3001-10	Tablespoon
3001-03	Dinner Spoon
3001-05	Dinner Fork
3001-07	Oyster Fork
3001-06	Salad Fork
3001-08	Dinner Knife
3001-12	Butter Spreader

CAC®



### Prime Flatware

- 18/0 stainless steel
- Extra heavy weight
- Packed 1 dz

3002-01	Teaspoon
3002-04	Bouillon Spoon
3002-02	Iced Tea Spoon
3002-09	Demitasse Spoon
3002-10	Tablespoon
3002-03	Dinner Spoon
3002-05	Dinner Fork
3002-07	Oyster Fork
3002-06	Salad Fork
3002-08	Dinner Knife



### Dakota Satin Flatware

- 18/0 stainless steel
- Heavy weight 2-2.2 mm
- Packed 1 dz

SLDK102	Teaspoon
SLDK103	Bouillon Spoon
SLDK105	Iced Tea Spoon
SLDK106	Dinner Fork
SLDK107	Salad Fork
SLDK109	Dinner Knife



### Jewel Flatware

- 18/0 stainless steel
- Heavy weight 2.2mm
- Packed 1 dz

SLNP002	Teaspoon
SLNP003	Bouillon Spoon
SLNP005	Iced Tea Spoon
SLNP006	Dinner Fork
SLNP007	Salad Fork
SLNP009	Dinner Knife



### Domilion Flatware

- 18/0 stainless steel
- Packed 1 dz

#### Medium Weight-1.5 mm

SLDO002	Teaspoon
SLDO003	Bouillon Spoon
SLDO005	Ice Tea Spoon
SLDO006	Dinner Fork
SLDO007	Salad Fork
SLDO009	Dinner Knife

#### Heavy Weight-2.5 mm

SLDO102	Teaspoon
SLDO103	Bouillon Spoon
SLDO105	Iced Tea Spoon
SLDO106	Dinner Fork
SLDO107	Salad Fork
SLDO109	Dinner Knife



### Legend Flatware

- 18/0 stainless steel
- Heavy weight 2.5-3mm
- Packed 1 dz

SLGD002	Teaspoon
SLGD003	Bouillon Spoon
SLGD005	Iced Tea Spoon
SLGD006	Dinner Fork
SLGD007	Salad Fork
SLGD009	Dinner Knife



### Esquire Flatware

- 18/0 stainless steel
- Heavy weight 2-2.2 mm
- Packed 1 dz

SLES102	Teaspoon
SLES103	Bouillon Spoon
SLES105	Iced Tea Spoon
SLES106	Dinner Fork
SLES107	Salad Fork
SLES109	Dinner Knife



### Tahoe Flatware

- 18/0 stainless steel
- Heavy weight 2-2.2 mm
- Packed 1 dz

SLTE102	Teaspoon
SLTE103	Bouillon Spoon
SLTE106	Dinner Fork
SLTE107	Salad Fork
SLTE109	Dinner Knife



### Salem Flatware

- 18/0 stainless steel
- Heavy weight 2-2.2 mm
- Packed 1 dz

SLAM102	Teaspoon
SLAM103	Bouillon Spoon
SLAM105	Iced Tea Spoon
SLAM106	Dinner Fork
SLAM107	Salad Fork
SLAM109	Dinner Knife



### Sunflower Flatware

- 18/0 stainless steel
- Heavy weight 1.8-2 mm
- Packed 1 dz

SLSF112	Teaspoon
SLSF113	Bouillon Spoon
SLSF115	Iced Tea Spoon
SLSF116	Dinner Fork
SLSF117	Salad Fork
SLSF119	Dinner Knife

## Windsor Flatware

- 18/0 stainless steel
- 1.5 mm
- Packed 1 dz

### Medium Weight-1.5 mm

- SLWD002 Teaspoon
- SLWD003 Bouillon Spoon
- SLWD005 Iced Tea Spoon
- SLWD006 Dinner Fork
- SLWD007 Salad Fork
- SLWD009 Dinner Knife

### Heavy Weight-2.5 mm

- SLWD102 Teaspoon
- SLWD103 Bouillon Spoon
- SLWD105 Iced Tea Spoon
- SLWD106 Dinner Fork
- SLWD107 Salad Fork
- SLWD109 Dinner Knife



## Sea Shell Flatware

- 18/0 stainless steel
- Heavy weight 2.5-3 mm
- Packed 1 dz

- SLSS002 Teaspoon
- SLSS003 Bouillon Spoon
- SLSS005 Iced Tea Spoon
- SLSS006 Dinner Fork
- SLSS007 Salad Fork
- SLSS009 Dinner Knife



TABLETOP

## Atlantic Flatware

- 18/10 stainless steel
- Packed 1 dz

- SLAT202 Teaspoon
- SLAT203 Bouillon Spoon
- SLAT205 Iced Tea Spoon
- SLAT206 Dinner Fork
- SLAT207 Salad Fork
- SLAT209 Dinner Knife



## Diamond Flatware

- 18/10 stainless steel
- Packed 1 dz

- SLDM202 Teaspoon
- SLDM203 Bouillon Spoon
- SLDM205 Iced Tea Spoon
- SLDM206 Dinner Fork
- SLDM207 Salad Fork
- SLDM209 Dinner Knife



## Elizabeth Flatware

- 18/10 stainless steel
- Packed 1 dz

- SLEL202 Teaspoon
- SLEL203 Bouillon Spoon
- SLEL205 Iced Tea Spoon
- SLEL206 Dinner Fork
- SLEL207 Salad Fork
- SLEL209 Dinner Knife

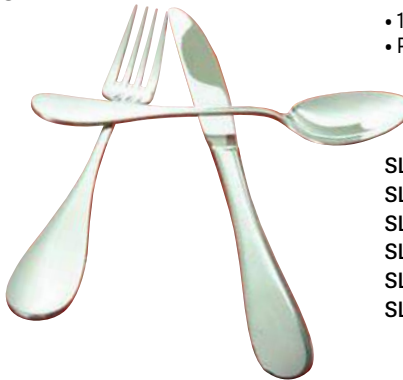

## York Flatware

- 18/10 stainless steel
- Packed 1 dz

- SLYK202 Teaspoon
- SLYK203 Bouillon Spoon
- SLYK205 Iced Tea Spoon
- SLYK206 Dinner Fork
- SLYK207 Salad Fork
- SLYK209 Dinner Knife



## Simplcity Flatware

- 18/10 stainless steel
- Packed 1 dz

- SLSM202 Teaspoon
- SLSM203 Bouillon Spoon
- SLSM205 Iced Tea Spoon
- SLSM206 Dinner Fork
- SLSM207 Salad Fork
- SLSM209 Dinner Knife



## Wilshire Flatware

- 18/10 stainless steel
- 2.2 mm
- Packed 1 dz

- SLWH202 Teaspoon
- SLWH203 Bouillon Spoon
- SLWH205 Iced Tea Spoon
- SLWH206 Dinner Fork
- SLWH207 Salad Fork
- SLWH209 Dinner Knife

# TABLETOP

## Hallmark Collection 2000™ 18/10 Flatware



### Athenian™

- 2601 Teaspoon
- 2604 Iced Tea Spoon
- 2605 Dinner Fork
- 2606 Salad Fork
- 2645 Knife, 1 Pc



### Modenaire™

- 2001 Teaspoon
- 2004 Iced Tea Spoon
- 2005 Dinner Fork
- 2006 Salad Fork
- 2045 Knife, 1 Pc



### Dramatique™

- 2201 Teaspoon
- 2204 Iced Tea Spoon
- 2205 Dinner Fork
- 2206 Salad Fork
- 2245 Knife, 1 Pc



### Soprano™

- 5201 Teaspoon
- 5204 Iced Tea Spoon
- 5205 Dinner Fork
- 5215 Cocktail Fork
- 52451 Knife, European, S.H.



### Vogue™

- 2501 Teaspoon
- 2504 Iced Tea Spoon
- 2505 Dinner Fork
- 2506 Salad Fork
- 2545 Knife, 1 Pc



## MAKE YOUR FLATWARE LAST

- Never allow flatware to remain soiled overnight
- Always presoak flatware immediately after use - wash flatware immediately after presoak and dry after rinsing
- Always change presoak solution frequently
- Never presoak flatware for longer than 15 minutes
- Always dissolve liquid and powder presoak compounds completely before adding flatware
- Always wash flatware in a vertical position in temperatures above 135°F - rinse in clean water at 180°F
- Always use only plastic or stainless steel containers for presoaking flatware
- Always use a non-abrasive, non-corrosive cleaning agent and a water softener or wetting agent



**Illustra™**

- 9101 Teaspoon
- 9104 Iced Tea Spoon
- 9105 Dinner Fork
- 9106 Salad Fork
- 9145 Knife, 1 Pc



**Bosa Nova - 18/0**

- 1801 Teaspoon
- 1804 Iced Tea Spoon
- 1805 Dinner Fork
- 1815 Cocktail Fork
- 18051 Table Fork



**18/10 Flatware**

**Soho™**

- 0701 Teaspoon
- 0704 Iced Tea Spoon
- 0705 Dinner Fork
- 07051 Euro Table Fork
- 0745 Dinner Knife



**Joreen™**

- 3001 Teaspoon
- 3004 Iced Tea Spoon
- 3005 Dinner Fork
- 30051 Table Fork
- 3045 Dinner Knife



**Goddess™**

- 2101 Teaspoon
- 2104 Iced Tea Spoon
- 2105 Dinner Fork
- 2106 Salad Fork
- 2145 Knife, 1 Pc



**Pacific Rim™**

- PAC01 Teaspoon
- PAC04 Iced Tea Spoon
- PAC05 Dinner Fork
- PAC06 Salad Fork
- PAC45 Knife, 1 Pc



**Hyannis™**

- 4901 Teaspoon
- 4904 Iced Tea Spoon
- 4905 Dinner Fork
- 4906 Salad Fork
- 4945 Knife, 1 Pc



**Napa™**

- 8101 Teaspoon
- 8104 Iced Tea Spoon
- 8105 Dinner Fork
- 8106 Salad Fork
- 8145 Dinner Knife



# TABLETOP

## Sonnet™

• Premium 18/0 flatware

- 8201 Teaspoon
- 8204 Iced Tea Spoon
- 8205 Dinner Fork
- 8206 Salad Fork
- 8245 Knife, 1 Pc



## Fanfare™

• Premium 18/0 flatware

- 2801 Teaspoon
- 2804 Iced Tea Spoon
- 2805 Dinner Fork
- 2806 Salad Fork
- 2845 Knife, 1 Pc



## Accolade™

- 4501 Teaspoon
- 4504 Iced Tea Spoon
- 4505 Dinner Fork
- 4506 Salad Fork
- 4545 Knife, 1 Pc



## Patrician™

- 3801 Teaspoon
- 3804 Iced Tea Spoon
- 3805 Dinner Fork
- 3806 Salad Fork
- 3845 Knife, 1 Pc



## Barclay™

- 1101 Teaspoon
- 1104 Iced Tea Spoon
- 1105 Dinner Fork
- 1106 Salad Fork
- 1145 Knife, 1 Pc



## Royal Bristol™

- 5101 Teaspoon
- 5104 Iced Tea Spoon
- 5105 Dinner Fork
- 5106 Salad Fork
- 5145 Knife, 1 Pc



## Dominion™

• Medium weight

- 7401 Teaspoon
  - 7404 Iced Tea Spoon
  - 7405 Dinner Fork
  - 7406 Salad Fork
  - 7443 Knife, 1 Pc
- Also available in heavy weight



## Poise™

- 5501 Teaspoon
- 5504 Iced Tea Spoon
- 5505 Dinner Fork
- 5506 Salad Fork
- 5545 Knife, 1 Pc



## Windsor™

• Medium weight

- 7201 Teaspoon
  - 7204 Iced Tea Spoon
  - 7205 Dinner Fork
  - 7206 Salad Fork
  - 7224 Knife, 1 Pc
- Also available in heavy weight





## Steak Knives

- Stainless steel blades resist rust, corrosion and discoloration
- Cutting is easy with fine quality serrated blades
- Excellent choice of wood or polypropylene handles



- 620527 5" S/S Round Tip Blade, Jumbo With Polypropylene Handle  
 680527 Kansas City™, Delrin™ Plastic Handle  
 660537 Utica II™, Round Tip Blade, Jumbo With Lacquered Hardwood Handle  
 630527 5" S/S Round Tip Blade, Jumbo With Wood Handle  
 640527 5" S/S Pointed Tip Blade, Jumbo With Wood Handle  
 980527 Round Tip Blade, Delrin™ Plastic Handle, Heavy-Duty, Full Tang



620527

680527

660537

630527

640527

980527



TABLETOP

## Chateau

• 18/8 flatware

- 2610STSF Teaspoon  
 2610SITF Iced Tea Spoon  
 2610FRSF Dinner Fork  
 2610FSLF Salad Fork  
 2610KPVF Dinner Knife, 1 Pc



## Arbor Rose

• 18/10 flatware

- 2552STSF Teaspoon  
 2552SITF Iced Tea Spoon  
 2552FRSF Dinner Fork  
 2552FSLF Salad Fork  
 2552KPVF Dinner Knife, 1 Pc



# TABLETOP

## Vina™

		PK
7509	Balloon, 16 oz, H7 $\frac{7}{8}$ " D3 $\frac{3}{8}$ "	1 dz
7515	Diamond Balloon, 18 $\frac{1}{4}$ oz, H8 $\frac{1}{2}$ " D4"	1 dz
7516	Diamond Tall Wine, 12 $\frac{1}{2}$ oz, H8 $\frac{5}{8}$ " D3 $\frac{1}{4}$ "	1 dz
7502	Tall Wine, 12 oz, H8 $\frac{5}{8}$ " D3 $\frac{3}{8}$ "	1 dz
7512	Martini, 8 oz, H6 $\frac{7}{8}$ " D4 $\frac{1}{8}$ "	1 dz
7518	Martini, 10 oz, H7 $\frac{1}{4}$ " D4 $\frac{5}{8}$ "	1 dz
7510	Tall Wine, 16 oz, H9" D3 $\frac{1}{2}$ "	1 dz
7504	Tall Wine, 18 $\frac{1}{2}$ oz, H9 $\frac{1}{8}$ " D3 $\frac{5}{8}$ "	1 dz

Jackson & Associates Presents...



## Perception

		PK
3088	Cordial, 4 oz, H5 $\frac{5}{8}$ " D2 $\frac{3}{8}$ "	2 dz
3096	Flute, 5 $\frac{3}{4}$ oz, H8 $\frac{1}{2}$ " D2 $\frac{3}{4}$ "	1 dz
3061	Balloon, 20 oz, H8 $\frac{1}{2}$ " D4 $\frac{1}{8}$ "	1 dz
3010	Banquet Goblet, 14 oz, H6 $\frac{1}{2}$ " D3 $\frac{3}{8}$ "	2 dz
3011	Tall Goblet, 14 oz, H8 $\frac{1}{4}$ " D3 $\frac{3}{8}$ "	2 dz
3060	Tall Wine, 20 oz, H8 $\frac{7}{8}$ " D4 $\frac{1}{8}$ "	1 dz
3069	Red Wine, 6 $\frac{1}{2}$ oz, H6 $\frac{1}{2}$ " D3"	2 dz
3064	Red Wine, 8" oz, H7" D3 $\frac{3}{8}$ "	2 dz
3056	Red Wine, 10 oz, H7 $\frac{7}{8}$ " D3 $\frac{3}{8}$ "	2 dz
3014	Red Wine 13 $\frac{1}{2}$ oz, H7 $\frac{3}{4}$ " D3 $\frac{3}{8}$ "	2 dz
3058	White Wine 6 $\frac{1}{2}$ oz, H7" D2 $\frac{3}{4}$ "	2 dz
3065	Wine, 8 oz, H7 $\frac{1}{4}$ " D3"	2 dz
3057	Wine 11 oz, H7 $\frac{7}{8}$ " D3 $\frac{3}{8}$ "	2 dz
3055	Cocktail Coupe, 8 $\frac{1}{2}$ oz, H6" D4 $\frac{1}{8}$ "	1 dz

Jackson & Associates Presents...



## Perception Tumblers

		PK
2391	Rocks, 7 oz, H3 $\frac{3}{8}$ " D3"	2 dz
2392	Rocks, 9 oz, H3 $\frac{3}{8}$ " D3 $\frac{1}{8}$ "	2 dz
2394	Double Old Fashioned, 12 $\frac{1}{2}$ oz, H4 $\frac{1}{8}$ " D3 $\frac{1}{2}$ "	2 dz
2393	Beverage, 12 oz, H5 $\frac{3}{4}$ " D2 $\frac{1}{8}$ "	2 dz
2395	Beverage, 14 oz, H6 $\frac{1}{8}$ " D3"	2 dz
2396	Cooler, 16 oz, H6 $\frac{3}{8}$ " D3 $\frac{1}{8}$ "	2 dz



## Stemless

		PK
217	White Wine, 11 $\frac{1}{4}$ oz, H4" D3 $\frac{1}{4}$ "	1 dz
221	White Wine, 17 oz, H4 $\frac{1}{2}$ " D3"	1 dz
222	Red Wine, 16 $\frac{3}{8}$ oz, H3 $\frac{3}{8}$ " D3 $\frac{3}{8}$ "	1 dz
224	Martini, 13 $\frac{1}{2}$ oz, H3 $\frac{3}{2}$ " D4 $\frac{1}{2}$ "	1 dz
228	Flute, 8 $\frac{1}{2}$ oz, H5 $\frac{3}{4}$ " D2 $\frac{1}{4}$ "	1 dz

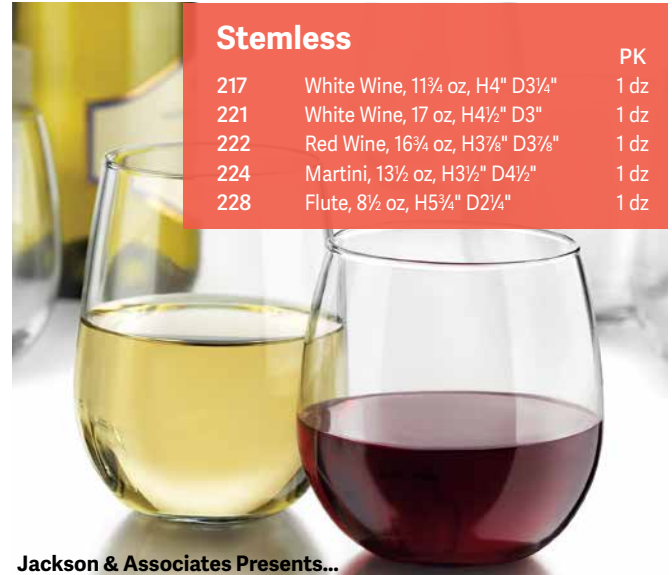

Jackson & Associates Presents...



## Series V Tumblers

• SheerRim/D.T.E.<sup>®</sup> (Dura Temp Edge)

11110722	Shooter, 2¼ oz, H2¾" D2¼"
11058021	Rocks, 8½ oz, H4½" D3½"
11106421	Rocks, 11 oz, H4¾" D3⅞"
11057822	Cocktail, 7½ oz, H3½" D4⅞"
11106520	Double Old Fashioned, 11⅞ oz, H4⅞" D3⅞"
11106721	Hi-Ball, 14¼ oz, H6¾" D3⅞"
11058521	Beverage, 14⅞ oz, H6⅞" D3¼"

Jackson & Associates Presents...



TABLETOP



Jackson & Associates Presents...



## Embassy<sup>®</sup>

- One-piece design for added strength and beauty
- Safedge<sup>®</sup> rim and foot guarantee



		PK			PK
3769	Wine, 6½ oz, H5⅞" D2⅞"	2 dz	3770	Cocktail, 4½ oz, H5⅞" D2⅞"	3 dz
3764	Wine, 8½ oz, H5⅞" D3⅞"	2 dz	3701	Mini Martini, 3 oz, H3¾" D3⅞"	1 dz
3757	Wine, 10½ oz, H6" D3⅞"	3 dz	3771	Cocktail, 5 oz, H5¼" D3¾"	3 dz
3766	Wine, 6½ oz, H6¼" D2⅞"	3 dz	3779	Martini, 9¼ oz, H6½" D4⅞"	1 dz
3765	Wine, 8½ oz, H6⅞" D2¾"	2 dz	3712	Banquet Goblet, 10½ oz, H5¼" D3⅞"	2 dz
3794	Flute, 4½ oz, H7⅞" D2½"	1 dz	3711	Goblet, 11½ oz, H6⅞" D3¼"	2 dz
3795	Flute, 6 oz, H8⅞" D2¾"	1 dz	3746	Footed Rocks, 5½ oz, H4½" D3⅞"	2 dz
3787	Champagne, 3½ oz, H4½" D3⅞"	3 dz	3747	Footed Rocks, 7 oz, H4¾" D3¼"	2 dz
3773	Champagne, 5½ oz, H4½" D3⅞"	3 dz	3736	Footed Hi-Ball, 8 oz, H 5⅞" D2¾"	2 dz
3790	Cordial, 1¼ oz, H4½" D1¼"	3 dz	3737	Footed Hi-Ball, 10 oz, H6" D2⅞"	2 dz
3792	Brandy, 2 oz, H4¼" D1¼"	1 dz	3725	Beer, 12 oz, H7⅞" D2¾"	3 dz
3788	Sherry, 3 oz, H4¾" D2⅞"	1 dz	3727	Beer, 10 oz, H6¾" D2¾"	2 dz
3702	Brandy, 5½ oz, H4½" D2⅞"	1 dz	3728	Beer, 12 oz, H7⅞" D2⅞"	2 dz
3705	Brandy, 11½ oz, H5" D3⅞"	2 dz			

# TABLETOP



## Cabernet

		PK
48024	Flute, 6 oz, H8 <sup>7</sup> / <sub>8</sub> " D2 <sup>3</sup> / <sub>4</sub> "	2 dz
D0796	Champagne Flute, 8 oz, H9 <sup>3</sup> / <sub>8</sub> " D2 <sup>3</sup> / <sub>4</sub> "	2 dz
50816	Tall Wine, 10 <sup>1</sup> / <sub>2</sub> oz, H7 <sup>3</sup> / <sub>4</sub> " D3 <sup>1</sup> / <sub>16</sub> "	2 dz
46973	Tall Wine, 12 oz, H8" D3 <sup>3</sup> / <sub>16</sub> "	2 dz
46961	Tall Wine, 16 oz, H8 <sup>5</sup> / <sub>8</sub> " D3 <sup>1</sup> / <sub>2</sub> "	2 dz
46888	Tall Wine, 19 <sup>1</sup> / <sub>4</sub> oz, H9 <sup>1</sup> / <sub>16</sub> " D3 <sup>11</sup> / <sub>16</sub> "	2 dz
47019	Balloon Wine, 12 oz, H7 <sup>3</sup> / <sub>16</sub> " D3 <sup>5</sup> / <sub>8</sub> "	2 dz
47017	Balloon Wine, 16 oz, H7 <sup>3</sup> / <sub>4</sub> " D3 <sup>7</sup> / <sub>8</sub> "	2 dz
14798	Port, 4 oz, H5 <sup>7</sup> / <sub>8</sub> " D2 <sup>1</sup> / <sub>8</sub> "	2 dz
G3570	Iced Tea, 16 oz, H7 <sup>1</sup> / <sub>16</sub> " D3 <sup>3</sup> / <sub>16</sub> "	2 dz

Jackson & Associates Presents...



## Durability & Style!

Cabernet stemware is the classic best seller. A wide variety of capacities and shapes makes it the perfect solution between trendy and traditional.

To learn more visit: [www.cardinalfoodservice.com](http://www.cardinalfoodservice.com)



## Grand Cépages All Purpose

• Packed 2 dz

G3573 13<sup>1</sup>/<sub>2</sub> oz, H6<sup>5</sup>/<sub>16</sub>" D3<sup>3</sup>/<sub>16</sub>"

Jackson & Associates Presents...



## Contour

- Superior performance and striking design
- Its unforgettable style thrives under rigorous uses

		PK
9231	Wine, 12 oz	1 dz
9152	Wine, 16 oz	1 dz
9234	Wine, 22 oz	1 dz

Jackson & Associates Presents...



## Distill Whiskey

- Round bowl with heavy base
- Stackable
- Sheer Rim® D.T.E.
- Packed 1 dz

Jackson & Associates Presents...



2999SR 10½ oz, H4⅞" D3⅜"



## Modernist

- Unassuming yet surprisingly bold, fits any venue
- High-performance durability

		PK
9033	Rocks, 7 oz	2 dz
9034	Rocks, 9 oz	2 dz
9035	Rocks, 10½ oz	2 dz
9036	DOF, 12 oz	2 dz
9038	Beverage, 12 oz	2 dz



Jackson & Associates Presents...



## Aruba Glassware

- Stunning cobalt blue foot and rim perfect for highlighting signature beverages

		PK
92301	Shooter, 3 oz, H4⅞" D1⅞"	1 dz
92302	Rocks, 12 oz, H3⅝" D3⅜"	1 dz
92303	Cooler, 16 oz, H5⅝" D3¼"	1 dz
92304	Zombie, 16 oz, H7¼" D2¾"	1 dz
92306	Cocktail, 15 oz, H7" D6"	1 dz
92307	Cocktail, 24 oz, H7⅝" D6⅞"	1 dz
92308	Margarita, 12 oz, H6⅝" D4⅝"	1 dz
92309	Round Cocktail, 16 oz, H7¼" D4¼"	1 dz

Jackson & Associates Presents...



# TABLETOP

Jackson & Associates  
Presents...

**ANCHOR  HOCKING™**

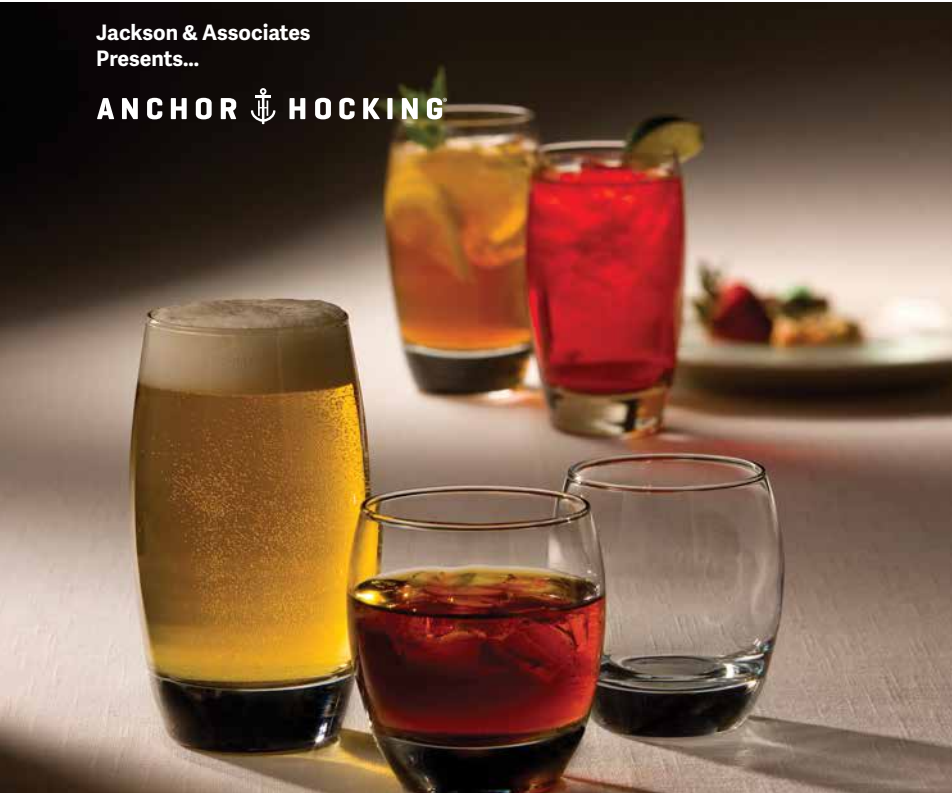

## Reality™

• Rim tempered

		PK
90044	Rocks, 10 oz, H3¾" D3¾"	2 dz
90045	Rocks, 12 oz, H3¾" D3½"	2 dz
90046	Tumbler, 14 oz, H5½" D3¼"	2 dz
90047	Cooler, 16 oz, H5½" D3¼"	2 dz
90048	Cooler, 20 oz, H6" D3½"	2 dz



Jackson & Associates Presents...

**ANCHOR  HOCKING™**

## Mixing Glasses

		PK
77174*	14 oz, H5½" D3½"	3 dz
176FU	16 oz, H5½" D3¼"	2 dz
7176FU*	16 oz, H5½" D3¼"	2 dz
77420*	20 oz, H6½" D3¾"	2 dz
77422*	22 oz, H6½" D3¾"	2 dz

\* Rim Tempered

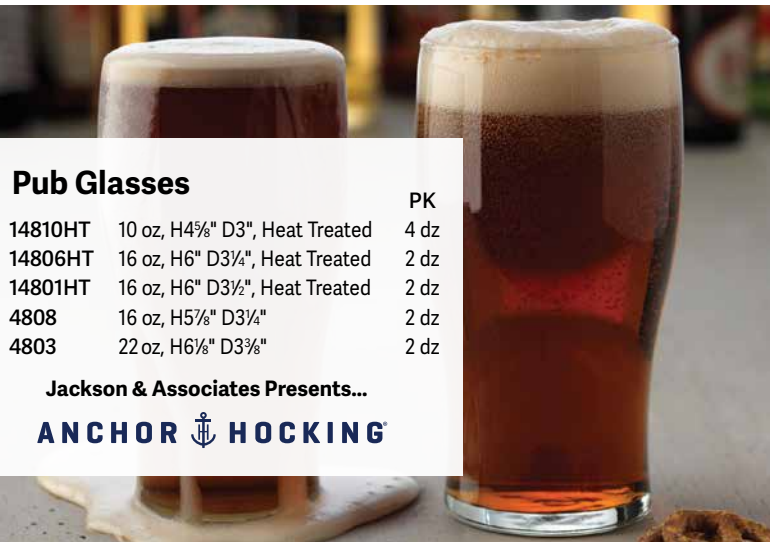

## Pub Glasses

		PK
14810HT	10 oz, H4¾" D3", Heat Treated	4 dz
14806HT	16 oz, H6" D3¼", Heat Treated	2 dz
14801HT	16 oz, H6" D3½", Heat Treated	2 dz
4808	16 oz, H5½" D3¼"	2 dz
4803	22 oz, H6½" D3¾"	2 dz

Jackson & Associates Presents...

**ANCHOR  HOCKING™**

## Paneled Steins

		PK
C1643	10 oz, H5½" D4¾"	1 dz
C1646	12 oz, H5½" D4¾"	3 dz

Jackson & Associates  
Presents...

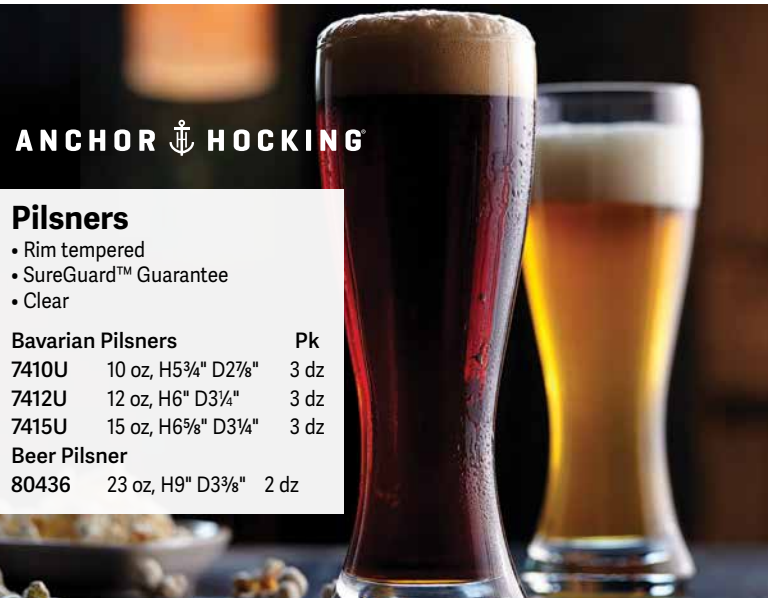

**ANCHOR  HOCKING™**

## Pilsners

- Rim tempered
- SureGuard™ Guarantee
- Clear

		Pk
7410U	10 oz, H5¾" D27/8"	3 dz
7412U	12 oz, H6" D3¼"	3 dz
7415U	15 oz, H6½" D3¼"	3 dz
<b>Beer Pilsner</b>		
80436	23 oz, H9" D3¾"	2 dz

## Specialty Drinking Jar

• Packed 1 dz

92103 16 oz, H5¼" D2⅝"



## Growler with Lid

• Allows customers to take home your craft beer and share with their friends  
• Packed 1 dz

70217 64 oz, H11" D5"

Jackson & Associates Presents...



TABLETOP

**Clarisse™ Stackable Tumblers**

- Rim tempered
- Packed 2 dz

90262	Rocks, 8 oz, H3½" D3¼"
90252	Rocks, 10 oz, H3⅝" D3½"
90253	DOF, 12 oz, H3⅝" D2⅞"
90254	Beverage, 14 oz, H5⅜" D3⅜"
90255	Cooler, 16 oz, H5¼" D3⅝"
90263	Cooler, 20 oz, H6⅝" D2⅝"

Jackson & Associates Presents...  
**ANCHOR HOCKING**

Jackson & Associates Presents...  
**ANCHOR HOCKING**

**New Orleans**

- SureGuard™ Guarantee

90004	Rocks, 4 oz, H3½" D2⅞"	PK
90005	Rocks, 5 oz, H3⅝" D2⅞"	3 dz
90009	Beverage, 10 oz, H3⅝" D3½"	3 dz
90010*	Double Rocks, 12 oz, H4¼" D3½"	3 dz
7732U*	Beverage, 12 oz, H4⅞" D3⅝"	3 dz
77746*	Cooler, 16 oz, H6⅝" D3⅝"	3 dz
77722*	Iced Tea, 22 oz, H7" D3¼"	2 dz

\* Rim Tempered

**Barbary Beer Collection**

- Use the serving paddle to serve a variety of shots and tasters to increase your beer sales and profits

93013A	Beer Glass, 4½ oz, H4" D2⅝"	PK
93012	Beer Glass, 13 oz, H6¼" D3"	2 dz
93011	Beer Glass, 16 oz, H6⅝" D3¼"	2 dz
90038	Serving Paddle, 14½"l x ⅝"h	1 dz

Jackson & Associates Presents...  
**ANCHOR HOCKING**

Jackson & Associates Presents...  
**ANCHOR HOCKING**

**Perfect Portions Mini Martini**

- Packed 3 dz

90063	2½ oz, H3¼" D3¼"
-------	------------------

Jackson & Associates Presents...  
**ANCHOR HOCKING**



## Lido Tumblers

- Easy to clean internal stacking ring promotes stable and space-efficient storage
- Prevent spills with tight fitting disposable Camlids®
- High temperature dishwasher safe
- Impact-resistant SAN material resists chips and breaks
- Lightweight with clear look of glass
- Packed 3 dz

LDT5	5 oz, H3 <sup>1</sup> / <sub>16</sub> " D2 <sup>5</sup> / <sub>16</sub> "	LDT12	12 oz, H4 <sup>15</sup> / <sub>16</sub> " D3"
LDT6	6 oz, H3 <sup>1</sup> / <sub>16</sub> " D2 <sup>1</sup> / <sub>16</sub> "	LDT16	16 oz, H5 <sup>5</sup> / <sub>16</sub> " D3 <sup>3</sup> / <sub>16</sub> "
LDT9	9 oz, H3 <sup>1</sup> / <sub>16</sub> " D3 <sup>3</sup> / <sub>16</sub> "	LDT22	22 oz, H6 <sup>7</sup> / <sub>8</sub> " D3 <sup>1</sup> / <sub>2</sub> "
LDT10	10 oz, H4 <sup>1</sup> / <sub>2</sub> " D2 <sup>7</sup> / <sub>8</sub> "		

**CAMBRO**  
TRUSTED FOR GENERATIONS™



## Clean Glassware!

Wash, store and safely transport stemware and tumblers in a revolutionary Camrack System that eliminates the need for rewashing.

To learn more visit: [www.cambro.com](http://www.cambro.com)

## Cirq™ Tumblers

- BPA-free SAN plastic
- Crystal-clear plastic with concentric circle pattern
- Break-resistant
- Stackable
- Commercial dishwasher safe

SW-1709-CL	9 oz
SW-1712-CL	12 oz
SW-1714-CL	10 oz
SW-1716-CL	16 oz
SW-1720-CL	20 oz





# Shining the **Spotlight** on Great Suppliers!

With every successful operation, there are a few common key factors including strategic marketing and investing in strong partnerships.

Creating a strong brand that can carry through to your marketing, advertising, signage, etc. is one way to set your operation apart from the crowd. By having a solid, strategic plan in place your operations and marketing efforts will align to your benefit.



Another important step is investing in strong partnerships with reliable suppliers. That's where our "**Supplier Spotlight**" comes in handy!

These suppliers are known for their extensive experience in the foodservice industry and take pride in working with dealers, like us, to maintain a strong relationship for years to come.

The right supplier brings state-of-the-art equipment and the latest trending smallwares. This means you and your staff have the best of both worlds, right at your fingertips!

To learn more visit: [buzztime.com/business](http://buzztime.com/business)



*Take a look at the variety of equipment and smallwares located on the following pages. Contact us and let us help guide you in making the right choices for your operation today!*

# SUPPLIER SPOTLIGHT

## Refrigerated Equipment Stands

- Heavy-duty bracing throughout
- Self-contained unit with balanced refrigeration system
- Self-closing drawers include 2 removable 12" x 20" x 4" deep polycarbonate pans
- 6" high removable legs

	Length	Drawers
3054-SR	54"	2
3076-SR	76"	4
3002-SR	102"	6



3076-SR  
Shown with optional casters

LAROSA

## Pizza Prep Tables

- 16 gauge stainless steel reinforced top
- Rigid polyurethane foam insulation
- Self contained unit
- Cold-wall construction on rail
- Condensate evaporator
- 6 1/4" removable swivel casters, front includes brakes
- Self closing door hinges
- Accommodates 1/2 size pans (not included)

	Length	Doors	Shelves	1/3 Pan Capacity
2562-PTB	62"	2	2	8
2586-PTB	86"	3	3	11
2510-PTB	112"	4	4	15
2067-PTB	67"	2	4	8
2093-PTB	93"	3	6	12
2096-PTB	96"	3	6	13



2586-PTB  
Shown with optional cutting board and pans, sold separately



## Glass Door Merchandisers

- Heavy-duty white coated steel interior and exterior
- Stainless steel floor
- CFC free foamed-in-place polyurethane insulation
- Double pane tempered glass door
- Adjustable screw down feet for leveling
- Forced air evaporator for quick temperature "Pull Down"
- Interior LED lighting
- 3 year parts and labor plus an additional 5 year warranty on compressor



Model	Doors/Shelves	Cu Ft	L x D x H	HP
<b>Countertop</b>				
DECK-10-HC	1/2	10	25.63" x 22.75" x 54"	1/4
DECK-12-HC	1/3	12	25.63" x 22.75" x 62"	1/4
<b>Hinged Glass Door</b>				
VR-7-HC	1/2	7	21.00" x 23.63" x 53.75"	1/5
VR-8-HC	1/3	8	21.00" x 23.63" x 59.13"	1/5
VR-10-HC*	1/3	10	22.75" x 25.63" x 54.00"	1/5
VR-12-HC*	1/3	12	25.63" x 22.75" x 62.00"	1/5
VR-15-HC	1/3	15	30.00" x 25.75" x 64.75"	1/4
VR-17-RE-HC	1/3	17	30.00" x 25.75" x 74.00"	1/4
VR-26-HC*	1/4	26	30.00" x 29.50" x 78.00"	1/3
VR-35-RE-HC	2/8	35	56.00" x 25.75" x 74.00"	1/3
CR-49-HC	2/8	49	60.00" x 29.50" x 78.00"	1/2
CR-65-HC	3/12	65	78.00" x 29.50" x 78.00"	3/4
<b>Sliding Glass Door</b>				
VR-45-SD-HC	2/8	45	51.00" x 29.75" x 78.00"	1/2

\*ENERGY STAR®



DECK-10-HC  
Bottom mounted self-contained refrigerated

DECK-12-HC

## Refrigerated Self-Serve High Profile Specialty Merchandisers

- Adjustable black metal shelves with price tag molding
- Top mounted fluorescent shielded light
- Electronic temperature control with on-demand defrost
- Choice of six standard laminates on exterior
- On demand PTC Condensate Evaporator
- Optional rear access doors
- Energy saving night curtain standard
- Attention getting design encourages impulse sales
- Available in 36", 47¼", 59¼" and 71¼" lengths



*The Signature of Quality*



### Convertible Service Over Refrigerated Self-Serve Merchandisers

- Display a variety of products with presentation in mind
- Available lengths include 36", 50", 59" and 77"



*Specialty Displays are customizable to your specifications and decor.*

*Choose from a variety of standard laminates or special order just the right color for your needs.*

*Contact your local sales representative for details.*

*Prepared Foods Merchandiser Self-Serve Refrigerator Shown*

## Italian Glass Display Cases

- Glass shelves adjust up and down and tilt in two positions
- 26" models have 2 tiers of shelves, 34" models have 3 tiers of shelves
- Tempered tilt-out front glass
- Straight glass for high visual product display
- Tempered glass top, ends, and doors
- Removable sliding rear doors
- Shielded 3500K LED top and shelf lights
- Steel base construction with choice of six standard laminates
- Stainless steel interior
- Leg levelers



Non-Refrigerated



Refrigerated



### Refrigerated Cases Additional Features:

- Rear air intake & discharge
- Condensate evaporator provided for a totally self-contained system
- Oversized coil and low-velocity fan system maintains high humidity and product freshness
- Easily accessible light switch, power switch, and electronic temperature control
- Average product temperature of 36° to 40°F
- DOE 2017 Compliant

# SUPPLIER SPOTLIGHT



SC-OD30E-4-LED

## Multipurpose Merchandisers

- Available in designer white, black or stainless steel
- High impact ABS bumper
- Removable ends for continuous lineups
- Three rows of lighted shelves
- Price tag molding on each shelf
- Energy efficient LED lighting systems
- Wide view Plexiglas front & sides
- Made in the USA

Open Ends - 30"d x 72"h	Length	HP
SC-OD30E-3-LED	39"	½
SC-OD30E-4-LED	51"	½
SC-OD30E-5-LED	63"	1
SC-OD30E-6-LED	75"	1
SC-OD30E-8-LED	99"	1
Sloped Ends - 34½"d x 78½"h		
SC-OD35E-3S-LED	39"	½
SC-OD35E-4S-LED	51"	¾
SC-OD35E-5S-LED	63"	1
SC-OD35E-6S-LED	75"	1



## Howard - McCray

### Ovations Multipurpose Open Merchandisers

- Available in designer white, black or stainless steel
- High impact ABS bumper
- Continuous lineup design
- Removable step shelf
- Wide view Plexiglas front & sides, curved or straight
- Maximum operating conditions - 75°F at 55% relative humidity
- 30"d x 44"h
- Made in the USA

	Length	HP
SC-OS30E-3	39"	½
SC-OS30E-4	51"	½
SC-OS30E-5	63"	¾
SC-OS30E-6	75"	¾



SC-OS30E-3



## 35 Series Open Produce Cases/Merchandisers

- Available in designer white, black or stainless steel
- Endless design allows for continuous line up
- Full length 24"h mirror to enhance product display
- Full length lighting at top of unit
- Telescoping display rack
- Self contained system (also available in remote, to order replace SC with R)
- 34½"d x 78½"h
- Made in the USA

## Howard - McCray

	Length	HP
SC-OP35E-3S-LED	39"	½
SC-OP35E-4S-LED	51"	¾
SC-OP35E-5S-LED	63"	1
SC-OP35E-6S-LED	75"	1
SC-OP35E-8S-LED	99"	1



## European-Design Gelato Display Cases

- Self-contained, air-cooled condensing unit
- LED lighting
- Steel chassis construction
- Standard creme front and side panels
- Roll down rear curtain
- Unique fan assisted airflow design
- Back and inside structure made of high gloss 304 stainless steel
- Heated front and side glass
- Hydraulic lift up front glass
- Stainless steel work surface
- Digital diagnostic control system with programmable defrosting
- 9° tilted display deck on gelato/ice cream showcases (Italiana)
- Multiplexing capability (Italiana)
- Available in linear and 30° curved designs (Italiana)
- Optional casters
- RAL custom color options
- Remotes available
- 220/60V

**ORION**  
by **CLABO**

By Howard McCray



ITA-G10-54-41-4P

Italiana, 35.25"d x 54"h	Pan Capacity	Length	HP
ITA-G10-54-41-4P	(10) 4 Liter	40.75"	¾
ITA-G10-54-41-5P	(7) 5 Liter	40.75"	¾
ITA-G16-54-41-4P	(16) 4 Liter	60.50"	1
ITA-G16-54-61-5P	(11) 5 Liter	60.50"	1
ITA-G22-54-80-4P	(22) 4 Liter	80.25"	1½
ITA-G22-54-80-5P	(16) 5 Liter	80.25"	1½

Evo, 41.72"d x 52.61"h	Pan Capacity	Length	HP
EVO-G6-53-47-5P	(12) 5 Liter	46.92"	1½
EVO-G6-53-47-12P	(8) 12 Liter	46.92"	1½
EVO-G9-53-66-5P	(18) 5 Liter	66.60"	2
EVO-G9-53-66-12P	(12) 12 Liter	66.60"	2
EVO-G12-53-86-5P	(24) 5 Liter	86.30"	2 x 1½
EVO-G12-53-86-12P	(16) 12 Liter	86.30"	2 x 1½



EVO-G6-53-47-12P

SUPPLIER SPOTLIGHT

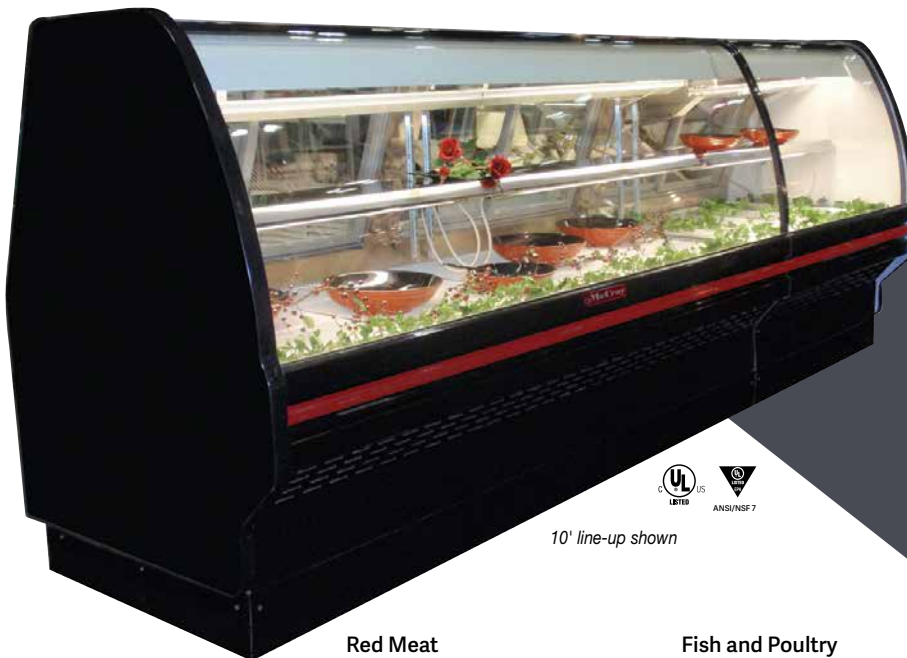

10' line-up shown

**Howard • McCray**

## Curved Glass Endless Design Service Cases

- Available in designer white, black or stainless steel exterior and white or stainless steel interior
- Epoxy coated main deck shelves
- Heavy-duty stainless steel top
- Extra wide double bend curved glass
- Endless design allows for continuous line ups
- Rear doors use the McGlide door system
- 1 row of LED lighting at top of unit
- Temperature and defrost electronically controlled
- 40"d x 53"h
- Available in remote (to order replace SC with R)
- Made in the USA

### Red Meat

- Self-contained - humidity coil
- SC-CMS40E-4C 51"w, ¼ hp
- SC-CMS40E-6C 75"w, ½ hp
- SC-CMS40E-8C 99"w, ½ hp

### Fish and Poultry

- Self-contained - S/S individual ice pans
- SC-CFS40E-4C 51"w, ¼ hp
- SC-CFS40E-6C 75"w, ¼ hp
- SC-CFS40E-8C 99"w, ½ hp

### Deli

- Self-contained - lighted mezzanine shelf
- SC-CDS40E-4C-LED 51"w, ¼ hp
- SC-CDS40E-6C-LED 75"w, ½ hp
- SC-CDS40E-8C-LED 99"w, ½ hp

# SUPPLIER SPOTLIGHT



Self-Contained, Remote and Dry models available

## KBD-CG Series Curved Glass Bakery Deli Case

- Medium temperature
- Case holds 36° to 40°F
- Forced air refrigeration
- Tempered tilt-out curved front glass
- LED lighting in canopy and under all shelves
- Digital controller with pressure alarm
- Removable rear tempered glass sliding door
- Anti-condensate system for front glass
- Height adjustable, tempered glass shelves can be tilted



Also available in Flat Glass

## KGL-OU Series Over/Under Combination

- Upper section operates refrigerated or dry
- Rear work shelf
- Open front, front loading lower section
- LED lighting under all shelves
- Silver colored PVC coated steel front panel
- PVC coated steel gray interior
- Wood laminate coated end panels
- CFC free injected foam insulation
- Height adjustable shelves can be tilted
- Removable condensate evaporating pan for easy cleaning
- Slide out condensing unit on self-contained units
- Temperature and defrost regulated by a digital controller
- 36" and 48" wide models available



## KGL-CH Series Grab-N-Go

- LED lighting under all shelves
- Silver colored PVC coated steel front panel
- PVC coated steel gray interior
- Wood laminate coated end panels
- CFC free injected foam insulation
- Height adjustable shelves can be tilted
- Removable condensate evaporating pan for easy cleaning
- Slide out condensing unit on self-contained units
- Temperature and defrost regulated by a digital controller
- 36", 48" and 60" wide models available



## KGV-MD Series High Volume Wall Case - Front Loading

- Refrigerated case holds 33° to 40°F
- Forced air refrigeration
- Front loading
- LED lighting in canopy and under shelves
- Silver colored PVC coated steel front panel
- CFC free injected foam insulation
- PVC coated steel gray interior
- Black steel kick plate
- Foamed polystyrene black end panels
- Height adjustable shelves can be tilted
- Temperature and defrost regulated by a digital controller
- Levelling feet
- Available from 2 to 6 doors
- 1 year parts and labor with an additional 4 years on the compressor (part only)



KGV-MR High Volume Front & Rear Loading; self-contained or remote available

KGV-MO High Volume Grab-N-Go Open Front; remote only



## KPM-FG Series Flat Glass Packaged Meat

- Tilt forward front-tempered glass
- Rear tempered sliding glass doors
- Digital controller
- LED canopy lighting
- Rear storage compartment
- Slide out condensation unit
- Anti-condensation system for front glass
- 60", 80", and 100" models available



Also available in Curved Glass, Self-Contained and Remote models available

## KFM-CG Series Curved Glass Fresh Meat Cases

- Tilt forward front-tempered glass
- Rear tempered sliding glass doors
- Digital controller
- LED canopy lighting
- Pull-out condensation unit
- Anti-condensation system for front glass
- Low velocity forced air refrigeration
- Stainless steel interior
- 48", 50", 60", 80", 100" and 120" models available



Also available in Flat Glass, Self-Contained and Remote models available



## Low & High Profile Open Merchandisers

- Refrigerated case holds 36° to 40°F
- Forced air refrigeration
- Pull-down night curtain
- Tempered side glass
- LED lighting in canopy and under all shelves
- Silver colored PVC coated steel front panel
- PVC coated steel gray interior
- CFC free injected foam insulation
- Foamed polystyrene black end panels
- Temperature and defrost regulated by a digital controller
- Digital thermometer
- Leveling feet

### KGL-OF Low Profile Cases

- 40", 50" and 60" wide models available

### KGH-OF High Profile Cases

- 30", 40", 50", 60", 80" and 100" wide models available

### KGH-ES Grab-N-Go High Profile Cases with Electric Shutter

- 30", 40", 50", 60", 80" and 100" wide models available



Low Profile



High Profile w/Electric Shutter



High Profile

Self-Contained and Remote models available

Dairy cases evolved! ➔

## KGL-RS Series Low Profile Grab-N-Go Cases

- Front and rear loading
- Electric or manual shutter
- Medium temperature
- Height adjustable shelves can be tilted
- LED lighting in canopy and under all shelves
- Temperature and defrost regulated by a digital controller
- Digital temperature data logger
- 40" and 60" models available



Manual Shutter also available



Rear Loading



Electric Shutter



# SUPPLIER SPOTLIGHT



## Back Bar Storage Coolers

- Sturdy, stainless steel top. Strong body with thick walls, injected with CFC free polyurethane foam
- Exterior cabinet made of pre-painted steel with baked polyester paint
- Interior lining made of acrylic-coated galvanized steel
- Forced air evaporator for quick temperature pull-down
- Fully sealed, reinforced 16 gauge galvanized steel base to prevent dirt accumulation underneath the unit
- Self-closing doors with safety stop at 120°, 1½" deep grip handles, incandescent interior lights
- 25"d x 36.5"h

	Length	Doors	Shelves	HP
MR-15-US	56.25"	2	4	¼
MR-15-GL	56.25"	2	4	¼
MR-25-US	69.13"	2	5	¼
MR-25-GL	69.13"	2	5	¼
MR-30-US	90.13"	3	6	½
MR-30-GL	90.13"	3	6	½



MR-15-US



## Bottle Coolers

- Wear resistant, textured baked enamel finish (black) with stainless steel countertop
- Galvanized steel interior
- Adjustable, heavy-duty epoxy coated steel wire storage bin dividers
- Heavy-duty bottle cap opener
- Holds 33° to 41°F
- Automatic, energy saving, non-electric condensate evaporator
- High density, non-CFC polyurethane foamed-in-place insulation
- 26½"d x 34¼"h

	Doors	Cu Ft	L x D x H	HP
BCX-50-DBST	2	14	50.00" x 26.50" x 33.19"	¼
BCX-65-DBST	2	19	65.00" x 26.50" x 33.19"	½
BCX-95-DBST	3	30	95.00" x 26.50" x 33.19"	½



BCX-65-DBST



## Beer Frosters

- Cabinet made of galvanized steel, internally reinforced to support the full weight of the beer bottles
- Full color decals to attract consumers at the point of sale
- Self contained heavy-duty condensing unit
- Forced-air evaporator for rapid temperature "Pull Down"

### Vertical Beer Frosters

- Heavy-duty hinges with automatic return and built-in door handle
- Modern high impact plastic front grill
- Curved foamed-in-place door made of galvanized steel (FROSTER 280)
- Modern thermoformed design of top header sign, door and grill stand out at the point of sale

### Horizontal Beer Frosters

- Stainless steel top and sliding doors



Vertical Beer Frosters	Doors	12 oz Bottles	Cu Ft	L x D x H	HP
FROSTER-B-280-HC	1 Solid	280	18	28.25" x 27.25" x 79.00"	⅓
FROSTER-B-18-HC	1 Glass	280	18	28.25" x 27.25" x 79.00"	⅓
FROSTER-B-30-HC	2 Glass	490	30	43.50" x 25.75" x 79.00"	2 x ¼
Horizontal Beer Frosters	Doors	12 oz Bottles	Cu Ft	L x D x H	HP
FROSTER-B-25-HC	1 Solid	96	5	26.00" x 27.25" x 33.63"	⅓
FROSTER-B-50-HC	2 Solid	336	15	51.25" x 27.25" x 33.63"	⅓
FROSTER-B-65-HC	3 Solid	480	21	66.25" x 27.25" x 33.63"	½
FROSTER-B-95-HC	4 Solid	720	31	96.00" x 27.25" x 33.63"	¾



FROSTER-B-280-HC



## Arctic Blue Line Series

- Foamed-in-place class 1 urethane panels with tongue and groove profile, cam lock connections and integral gasket
- 34" x 78" doors are centered, foamed-in-place, self-closing and flush mounted
- Doors include 24" high diamond tread kick-plates (int. & ext.)
- Key-lock handle
- Inside safety release
- Digital thermometer and light switch
- Vapor-proof door light centered over door
- Floorless models include NSF approved, coved base vinyl screens, pre-cut and mitered
- Available with self-contained or remote pre-assembled refrigeration
- 15 year panel warranty, 1 year refrigeration labor warranty, 1 year parts warranty, 5 year compressor warranty
- Quick ship product



All Arctic walk-ins certified and labeled to NSF STD 7 & UL STD 471



## Arctic Series 3000

- Foamed-in-place class 1 urethane panels with tongue and groove profile, cam lock connections and integral gasket
- 4" and 5 1/2" thick panel profiles available
- One piece corners
- Pre-assembled, inspected and photographed prior to all shipments
- 34" self-closing, in fitting, flush mounted door
- 36" high aluminum diamond tread kick plates interior and exterior
- Center mounted, factory installed vapor proof light fixture with safety night light
- LED digital thermometer with light switch
- Inside safety release
- 15 year panel warranty, 1 year refrigeration labor warranty, 1 year parts warranty, 5 year compressor warranty



SUPPLIER SPOTLIGHT



## Cold Pan Drop-In Units

- One-piece stainless steel top and interior
- Galvanized steel exterior housing
- High-density closed cell polyurethane insulation
- Sides and bottom are wrapped with refrigerated lines
- Mechanically cooled drop-in cold pan
- Condensing unit is suspended below cold pan
- Recessed openings can accommodate fractional sized pans up to 6"d
- Adapter bars provided for 12" x 20" pans (pans not included)

	Width	Cut-Out (W x D)	Full-Size Pan Capacity
4119-MCDB	18 7/8"	17 7/8" x 25 1/2"	1
4132-MCDB	31 5/8"	30 1/8" x 25 1/2"	2
4144-MCDB	44 3/8"	42 7/8" x 25 1/2"	3
4157-MCDB	57 7/8"	55 5/8" x 25 1/2"	4
4170-MCDB	69 7/8"	68 3/8" x 25 1/2"	5
4183-MCDB	82 5/8"	81 1/8" x 25 1/2"	6

# SUPPLIER SPOTLIGHT

CHEFTOP MIND.Maps™ PLUS is the intelligent combi oven that grills, fries, roasts, brown, smokes, cooks with steam and much more. Featuring automatic cooking cycles and intelligent functions to create impeccable and consistent results.



XACC-0513-EPRM



XAVC-1011-GPRM



XAVC-16FS-GPRM

Ready to learn more about these great products?  
**PLAY VIDEO**

## CHEFTOP MIND.Maps™ PLUS Combi Ovens

- AIR.MAXI™ technology ensures perfect distribution of air and heat within the cooking chamber
- 4 air speeds and 4 semi-static modes to perfectly cook a variety of menu items
- ADAPTIVE.Cooking™ technology interprets your settings, registers variations of humidity and temperature and gives you the perfect result
- Stainless steel interior & exterior

2½" Shelf Spacing			12" x 20"	
Electric	W x D x H	Voltage	Pan Capacity	
XACC-0513-EPRM	26⅛" x 33⅛" x 25⅜"⁄₄"	208/240	5	
XAVC-0511-EPRM	29⅞" x 30⅞" x 26⅞"	208/240	5	
XAVC-1011-EPRM	29⅞" x 30⅞" x 39⅜"⁄₄"	208/240	10	
Gas			BTU	
XAVC-0511-GPRM	29⅞" x 30⅞" x 26⅞"	51,182	5	
XAVC-1011-GPRM	29⅞" x 30⅞" x 39⅜"⁄₄"	75,067	10	
3⅞" Shelf Spacing			12" x 20"	
Electric	W x D x H	Voltage	Pan Capacity	
XAVC-06FS-EPRM	33⅞" x 37⅛"⁄₄" x 33¼"	208/240	12	
XAVC-10FS-EPRM	33⅞" x 37⅛"⁄₄" x 45⅜"⁄₄"	208/240	20	
XAVC-16FS-EPRM	34¼" x 41⅞" x 73½"	208/240	32	
Gas			BTU	
XAVC-06FS-GPRM	33⅞" x 37⅛"⁄₄" x 33¼"	81,891	12	
XAVC-10FS-GPRM	33⅞" x 37⅛"⁄₄" x 45⅜"⁄₄"	119,425	20	
XAVC-16FS-GPRM	34¼" x 41⅞" x 73½"	238,850	32	

## What is a combi oven?

Uses total or partial steam saturation to cook food, and it is able to recreate specific climatic conditions for each type of cooking, allowing you to:

- Cook with "dry" air (without humidity), which allows for higher heat cooking such as grilling, frying and browning, or delicate low temperature cooking such as dehydration of fruits and vegetables
- Cook with "mixed" air (with low percentages of humidity), which allows you to roast, cook at low temperature, braise, overnight cook and stew
- Steam cooking (with very high percentages of humidity) at any temperature like sous-vide cooking, regeneration, steaming, etc.

To learn more visit: [www.unox.com/us](http://www.unox.com/us)



**F330-2RB**  
Shown with optional casters

## Range Combos

- Custom specialty ranges
- Space saving (footprint and hood)
- Easy cleaning, corrosion resistant stainless steel finish, welded with angle iron and aluminized inner framing
- Industry's best insulation for efficiency

- Sturdy 6" heavy-duty stainless pipe legs with adjustable feet
- Made in USA



	Width	Burners	Configuration
F330-2RB	36"	2	(1) 31½" Oven, (1) 24" Broiler
F3430-24-1RB	48"	2	(1) 31½" Oven, (1) 24" Griddle, (1) 12" Broiler
F3226-30-1.5RB	60"	2	(2) 26½" Ovens, (1) 30" Griddle, (1) 18" Broiler
F3226-24-1RB	60"	4	(2) 26½" Ovens, (2) 24" Griddle, (1) 12" Broiler
2F330-1.5RB-30B	72"	4	(2) 31" Ovens, (1) 30" Raised Griddle, (1) 18" Charbroiler



**2F330-1.5RB-30B**  
Shown with optional casters



**F3430-24-1RB**  
Shown with optional casters

SUPPLIER SPOTLIGHT

## Gas Fryers

- Stainless steel fry tank and door, galvanized sides
- Tube type
- Snap action thermostat with standing pilot
- 6" stainless steel legs

	Oil Capacity	Width	BTU
GF120	(1) 50 lb	15½"	120,000
GF85	(1) 75 lb	21"	150,000
GF120T	(2) 25 lb	15"	120,000

GF120

GF120T

# SUPPLIER SPOTLIGHT



## Hot Food Serving Counter

- Electronic temperature controller for precise control of each hot well
- 6½" deep stainless steel wells with coved corners wrapped with 2" of high density fiberglass insulation
- Heavy-duty reinforced construction
- Armor Heat™ system for high efficiency
- Standard finish is stainless steel, a variety of powder coat colors available
- Standard with heavy-duty 5" casters
- 120V/1500W per well



HC46 3 Wells, 48"w x 30"d x 36"h



## Mobile Heated Cabinet

- Stainless steel interior and exterior
- Fully insulated
- Door louvered with adjustable damper
- Top mounted control
- 60° to 230°F temperature range
- Armor Heat™ system
- 5" casters
- Low power requirements
- 12 sets of universal angles hold 250 lb per pair, adjustable on 1½" centers, will accommodate (2) 12" x 20" pans or (1) 18" x 26" trays

M11UA12 25½"w x 35½"d x 71¾"h

## ServeWell® Hot Food Tables

- Stainless steel construction includes legs and undershelf
- One piece thermoset well cannot pit or rust
- Dome elements transfer energy directly into the water bath
- Four guide holes per side for Buffet Breath Guard attachment
- Equipped with standard 480W, 700W or 800W elements
- Each well is equipped with a brass drain valve
- Plate shelf and 8" wide cutting board on operator's side



120V/700W	120V/480W	208V/240V (600/800W)	Wells	Width
38102	38002	38116	2	32"
38103	38003	38117	3	46"
38104	38004	38118	4	61¼"
38105	38005	38119	5	76"



38103





**Hot Food Station**  
Shown in Granite



**Hot Food Station**  
Shown in Black



**All Affordable Portable™ food stations are available in Black, Walnut Woodgrain, Granite and Cherry Woodgrain. Ask your local sales representative for details.**

### Affordable Portable™ Food Stations

- A great value in mobile serving equipment
- Easy access, fully enclosed clear acrylic breath guard – 12" clearance
- Seamless one-piece 20 gauge, 300 series stainless steel work surface
- Stainless steel plate rest offers a wide, stable area – folds down for easy storage
- Optional storage with doors
- High density fiber glass insulation
- Scratch resistant vinyl clad steel in four colors
- All units 24"d x 35"h



**Cold Food Station**  
Shown in Black

#### Hot Food Stations

- Each well supplied with 120V element and infinite setting controls
- High density glass fiber insulation
- Spillage pans required – sold separately
- Infinite control switches
- Black

#### Cold Food Stations

- 20 gauge stainless steel work surface includes NSF2 buffet breath guard
- Non-refrigerated 6" deep well
- Foamed-in-place polyurethane foam insulation
- 1" drain makes cleanup easy
- Black

<b>3 Wells, 46"</b>	<b>4 Wells, 60"</b>	
38707	38710	Enclosed Base
38708	38711	Open Storage Base
38709	38712	Storage Base w/Doors

<b>3 Wells, 46"</b>	<b>4 Wells, 60"</b>	
38713	38716	Enclosed Base
38714	38717	Open Storage Base
38715	38718	Storage Base w/Doors

# SUPPLIER SPOTLIGHT

## Sealed Well Electric Steam Tables

- Electric hot food table with cutting board
- Thermostatic control (standard)
- Fiberglass insulated
- 18 gauge stainless steel undershelf
- Includes manifold drain assembly
- 22 $\frac{3}{8}$ "d x 34 $\frac{1}{8}$ "h

	Width	Wells	Watts	Volts
SW-2H-120	32"	2	1280	120
SW-3H-120	47 $\frac{1}{2}$ "	3	1920	120
SW-4H-120/208	62 $\frac{3}{4}$ "	4	2560	208
SW-5H-240/208	78 $\frac{1}{8}$ "	5	5500	208



SW-2H-120



WB3H



## Heavy-Duty Gas Wet Bath

- 20 gauge, Type 304 stainless steel
- STS gusset, STS square leg and STS feet
- Natural gas and LP compatible
- 30 $\frac{3}{8}$ "d x 34" h

	Width	Wells
WB2H	31 $\frac{3}{4}$ "	2
WB3H	47 $\frac{1}{2}$ "	3
WB4H	62 $\frac{1}{2}$ "	4
WB5H	77 $\frac{1}{2}$ "	5



HF4H

## Gas Steam Tables

- 304 stainless steel construction
- Individually-controlled wells
- Full length, 7" wide cutting board
- Open shelf base
- Water pans required (sold separately)
- Adjustable stainless steel feet

	Width	Wells	Burners	BTU
HF2H	30 $\frac{3}{8}$ "	2	2	6,400
HF3H	34 $\frac{3}{8}$ "	3	3	9,600
HF4H	58 $\frac{3}{8}$ "	4	4	12,800
HF5H	72 $\frac{3}{8}$ "	5	5	16,000

## Pop-Up Toasters

- Evenly toasts a variety of bread products including bagels, Texas toast, waffles and English muffins
- Four, 1 1/4" extra-wide self-centering slots
- Durable stainless steel construction
- Individual toasting controls
- Removable crumb tray for easy cleaning
- 120V/1800W

TPT-120 13 5/8"w x 12 3/8"d x 8 1/8"h



Nothing less than the best.®



## Toast-Qwik® Electric Conveyor Toasters

- Patented ColorGuard Sensing System monitors chamber temperature and adjusts conveyor speed to ensure consistent toast results
- Programmable Power Save mode activates manually or automatically
- Crumb tray is removable for easy cleaning
- Unique new toast delivery rack moves your product to the storage tray each and every time
- 120V/1780W

### TQ3-400:

- Stainless steel tray insert
- Dynamic new touchscreen controller that is easy to see and easier to use
- USB port for software updates

TQ3-10 14 1/2"w x 21 3/16"d x 16 3/16"h

TQ3-400 14 3/4"w x 20 3/8"d x 17 1/8"h



## Rice Cooker/Warmers

- Insulated, double wall stainless steel construction
- Automatically shifts to warm mode after cooking
- Moisture cup collects water for no-mess serving
- Trigger handle
- Easy-to-clean nonstick pot
- Also cooks grits, oatmeal and mac & cheese
- 120V
- 1 year warranty



**Proctor Silex**  
COMMERCIAL  
By Hamilton Beach



37540 40 Cups Cooked Rice  
37560R 60 Cups Cooked Rice, Heated Lid



## Glo-Ray® Infrared Food Warmers

- High wattage
- Tubular metal heater rod
- Aluminum construction
- S-hooks & chain
- Cord & attached plug
- 120V/60/1-ph
- Add suffix for controls: TCCS for built-in toggle switch, ICCS for built-in infinite switch

GRAH-24/AH24120 24"w, 500W

GRAH-30/AH30120 30"w, 660W

GRAH-36/AH36120 36"w, 800W

GRAH-48/AH48120 48"w, 1100W

GRAH-60/AH60120 60"w, 1400W

GRAH-72/AH72120 72"w, 1725W



Nothing less than the best.®



# SUPPLIER SPOTLIGHT

## Cayenne® Model 1001 Full Size Warmer

- Features Vollrath's exclusive direct contact heating system for energy efficiency and cool-to-touch exterior
- Thermostatic control supplies power only when needed for maximum efficiency
- Low-water indicator light eliminates guesswork
- Use with up to 4" d food pans
- 120V, 700W
- Made in USA

71001 13¾" w x 21¾" d x 9" h



## Mirage® Induction Rethermalizers

- Induction heating means no water required, faster retherm times and better temperature control
- Digital controls set temperature in °F and °C, or use presets for Soup, Crème Soup, Chili, Mac & Cheese
- Includes Vollrath induction ready inset and inset cover
- Requires use of Vollrath induction-ready inset—failure to use insets may damage the unit and will void the warranty
- Includes programmed retherm mode
- Available in Natural (10) or Red (40)
- 120V

**Induction Rethermalizers**  
 74701XX 7 qt  
 741101XX 11 qt

**Induction-Ready Insets**  
 88184 7 qt  
 88204 11 qt



## Countertop Glass Display Cabinets

- Inside lighting at the top of cabinet and under upper shelf creates optimum food display
- Dual fans circulate air throughout unit to ensure even temperature control
- Digitally controlled thermostat
- Triple-glazed front glass gives added strength and insulation
- Lift-and-remove rear sliding doors for easy display changes and end of day cleaning
- Refrigerated units: 36° to 46°F temperature range
- Heated units: 104° to 158°F temperature range
- Front access models have sliding doors
- Curved cabinets have 2 shelves, cubed have 3 shelves
- Note: these items must ship by truck
- 21¼" d x 37" h
- 120V cord and plug



40862



40881

### Refrigerated

**Cubed Front**  
 40862 36" w  
 40863 48" w  
 40864 60" w  
 40886 36" w, Front Access  
 40887 48" w, Front Access  
 40889 60" w, Front Access  
**Curved Front**  
 40880 36" w, Front Access  
 40881 48" w, Front Access  
 40882 60" w, Front Access

### Heated

**Cubed Front**  
 40865 36" w  
 40866 48" w  
 40867 60" w  
**Curved Front**  
 40890 36" w, Front Access  
 40891 48" w, Front Access  
 40892 60" w, Front Access





## Broilers

- Cast iron straight burners with heat reflector under-burner grease shield cast iron grates, each rated at 20,000 BTU
- Heavy-duty cast iron radiants
- Stainless steel splash guards
- Insulated stainless steel frame finish
- 4" stainless steel legs
- Two 20,000 BTU burners every 12"



	Width	Burners	BTU
CCHRB24	24"	4	80,000
CCHRB36	36"	6	120,000
CCHRB48	48"	8	160,000
CCHRB60	60"	10	200,000



## Countertop Gas Griddles

- Stainless steel finish
- 20,000 BTU burner every 12"
- Highly polished steel griddle plate
- 12" models feature a 3/4" thick plate, all other models are 1"
- 4" splash guard on back & ends
- 3" wide front grease trough
- Removable grease drawer
- 4" stainless steel legs
- Chrome & grooved tops available

Manual	Width	Burners	BTU
CCHG12	12"	1	30,000
CCHG24-1	24"	2	60,000
CCHG36-1	36"	3	90,000
CCHG48-1	48"	4	120,000
CCHG60-1	60"	5	150,000

Thermostat	Width	Burners	BTU
CCHG12T	12"	1	30,000
CCHG24T-1	24"	2	60,000
CCHG36T-1	36"	3	90,000
CCHG48T-1	48"	4	120,000
CCHG60T-1	60"	5	150,000

## UNIWORLD

### Gas Vertical Broilers

- Stainless steel body
- Heavy gauge frame construction
- 4 independent controls and pilot controller
- Adjustable burner panel
- Natural gas
- Sturdy skewer supports more than 35 lb of meat
- 50,000 BTU
- 21"w x 25 1/2"d x 39"h

VBR-2E Without Flaps  
VBR-2EF With Flaps

VBR-2EF



40716

### Cayenne® Electric Flat Top Griddles

- High output for busy kitchens
- Heavy-duty cooking surface for high heat retention
- 1/2" thick polished griddle plate
- Fast start-up to cooking temperatures
- Bottom mounted grease collection pan
- Thermostatically controlled
- Griddle plate is fully welded to base

40715 14 1/4"w, 110V

40716 24"w, 220V

40717 36"w, 220V



# SUPPLIER SPOTLIGHT

## Cayenne® Gas Charbroilers and Flat Top Griddles

- Stainless and aluminized steel with a fully welded construction
- Charbroilers have cast iron grates and a burner every 6"
- Griddles have ¾" polished steel plate and a burner every 12"
- Superior burners allow for fast recovery and improved heat distribution
- Shipped natural gas, includes conversion kit for LP
- 16" x 27"



### Radiant/Lava Rock Charbroilers

- 40728^ 12"w, 28,000 BTU
- 407292 18"w, 60,000 BTU
- 407302 24"w, 80,000 BTU
- 407312 36"w, 120,000 BTU
- 407372 48"w, 160,000 BTU
- 407382 60"w, 200,000 BTU

^12" unit has 1 burner

### Flat Top Griddles

- 40718 12"w, 28,000 BTU
- 40719^ 18"w, 28,000 BTU
- 40720 24"w, 56,000 BTU
- 40721 36"w, 84,000 BTU
- 40839 48"w, 112,000 BTU
- 40840 60"w, 140,000 BTU

^18" unit has 1 burner



PCG-GT

PCG-Base

## CRESTWARE

### Portable Commercial Griddle & Grill Box

- 4 independently controlled burners for constant, even heat distribution
- 15,000 BTU per burner
- Electronic ignition
- Large 36" x 20" cooking surface
- Legs fold for easy storage

- PCG-GT Steel Griddle Top
- PCG-Base Mobile Stainless Steel Base

- Optional Charbroiler
- S/S frame and wind guard
- 4" high wind guard on 3 sides

- PGB Optional Grill Box/Charbroiler



PGB



### Gas Griddle w/Manual Controls

- 1" thick highly polished steel griddle plate fully welded to a stainless steel frame
- 3 high-performance 30,000 BTU burners
- Stainless steel U-style burners provide flame every 6"
- Stainless steel, insulated double wall construction front, sides and back and extended cool-to-touch front edge
- Adjustable pilot for each burner
- Ships natural gas with LP conversion kit included
- Also available in 15", 24" and 48" widths
- 2 year parts & labor warranty
- cETLus, ETL

GG36G 36"w x 32<sup>17</sup>/<sub>32</sub>"d x 15<sup>3</sup>/<sub>4</sub>"h

### Gas Charbroiler

- Stainless steel, insulated double wall construction front and sides
- Stainless steel radiants
- Reversible cast-iron grates with drip flavor edge
- 40,000 BTU per burner with individual adjustable pilots
- Ships natural gas and includes LP conversion kit
- Also available in 15", 36" and 48" widths
- 2 year parts & labor warranty
- cETLus

GCB24G-SR 24"w x 30<sup>9</sup>/<sub>16</sub>"d x 15<sup>3</sup>/<sub>4</sub>"h



## Cayenne® Pizza Oven

- Stainless steel
- Two ceramic bake decks
- 15 minute timer function
- Heat setting: 140° to 750° F
- 208V - 240V



40848 23½" w x 25¾" d x 18⅞" h



40703



## Cayenne® Convection Ovens

- Custom baffle fan and specially designed diffuser plate creates even, reliable baking
- Insulated double-wall construction
- Temperature range: 150° - 570° F (66° - 299° C)
- Full size has steam inject for crispy bread crusts

40703 Half Size, 23⅞" w x 24½" d x 18⅞" h, 4 Shelves, 120V

40701 Half Size, 23⅞" w x 24½" d x 23¼" h, 3 Shelves, 230V

40702 Full Size, 32⅞" w x 29¾" d x 26⅞" h, 4 Shelves, 230V

## Deluxe Churro Makers

- Stainless steel construction
- Comes with 2 different stainless steel nozzle adapters: 1 for filling (hollow) and 1 for plain churros
- 2-gear speed system
- Portable and easy to operate
- Easy to clean



UCM-DL3 5 lb  
UCM-DL5 10 lb  
UCM-DL7 15 lb

UCM-DL5



## Electric Countertop Fryers

- Stainless steel construction
- 70° to 375° F thermostat
- Removable control box and element
- 2 nickel-plated fry baskets with insulated handles
- Swing up element and lift-out fry pot
- 3½" stainless steel adjustable feet
- Manual reset



	Capacity	W x D x H	Volt
PF10E Single Tank	10 lb Oil	11.6" x 17.5" x 14.8"	120
PF16E Single Tank	16 lb Oil	11.06" x 17.5" x 17"	208/240
PF32E Dual Tank	32 lb Oil	21.75" x 17.63" x 17.5"	208/240



PF32E

# SUPPLIER SPOTLIGHT



40831



40833

## In-Chamber Vacuum Pack Machines

- Stainless steel exterior and vacuum chambers
- Units feature Busch vacuum pump—best in the industry
- Removable seal bar is easy to clean and maintain
- Accommodates multiple bags at once
- Transparent, soft-open lid for monitoring

### 12" Seal Bar

- User definable vacuum setting and sealing time
- Can pack small products

### Dual 16" Seal Bars

- Can pack small products, liquids, and fine powders
- Ten programs include Liquid Control, Soft-Air and Vacuum Plus functions

40831 14½" x 17" x 4" Chamber

40833 16⅜" x 16½" x 5" Chamber

## In-Chamber Vacuum Pack Bags

- Pack of 100

### Regular

40815 8" x 12"  
40816 10" x 14"  
40817 12" x 16"  
40818 14" x 18"

### Boil-In

23850 6" x 8"  
23852 8" x 12"  
23854 12" x 16"



## Accuvide™ Immersion Circulator

- 1200 watt heater keeps up to 8 gallons of water at an even, consistent temperature
- Temperature range of 41°F (5°C) to 203°F (95°C) with display accuracy to 0.1 of a degree
- Cleaning cycle and reminder
- IPX7 construction prevents malfunction if accidentally dropped in water
- Dishwasher safe stainless steel housing
- Adjustable clamp
- 1 Year Expresscare Replacement Warranty

HSV1000

1200W



**Hamilton Beach**  
COMMERCIAL

Ready to learn more about these great products?

**PLAY VIDEO**



## Out-of-Chamber Vacuum Pack Machine

- Out-of-chamber vacuum packing – requires specific bag type
- Extends the shelf life of foods and cuts down on waste
- Not suited for use with liquids
- 12⅜" sealing bar

40858 14¾" w x 11⅞" d x 5⅞" h



## Out-of-Chamber Vacuum Pack Bags

40812 6" x 12"  
40813 8" x 12"  
40814 10" x 14"

## Prep it Right!

### Raw and cooked foods should be kept apart

- Use separate preparation areas (including sinks) for raw products like uncooked meat, poultry and seafood, and cooked or ready-to-eat foods.
- You should also have separate freezers and coolers. If you must store raw products in the same coolers and freezers, then you should store raw products well away from the prepared foods.

### All food should be covered while in storage

- Raw foods should be kept in separate containers that are well covered or have tight fitting lids.
- Always store raw products on a shelf lower than prepared foods.



Ready to learn more about these great products?

**PLAY VIDEO**



## PrimaVac™ In-Chamber Vacuum Sealers

- Powerful JetAire™ pump ensures 99.9% air evacuation
- 10 adjustable custom program settings
- Adjustable soft air, cooling and sealing time
- LED lights indicate each step in cycle
- Removable heat seal bar and filter plate
- Clear lid for viewing
- Gas flush (model HVC406 only)
- 3 year parts & labor warranty (when registered online)

### Seal Bar Length

	Seal Bar Length	W x D x H
HVC254	10"	13.27" x 17.95" x 14.85"
HVC305	12"	14.92" x 19.35" x 14.69"
HVC406	16"	19.45" x 24.25" x 19.13"

**Hamilton Beach**  
COMMERCIAL

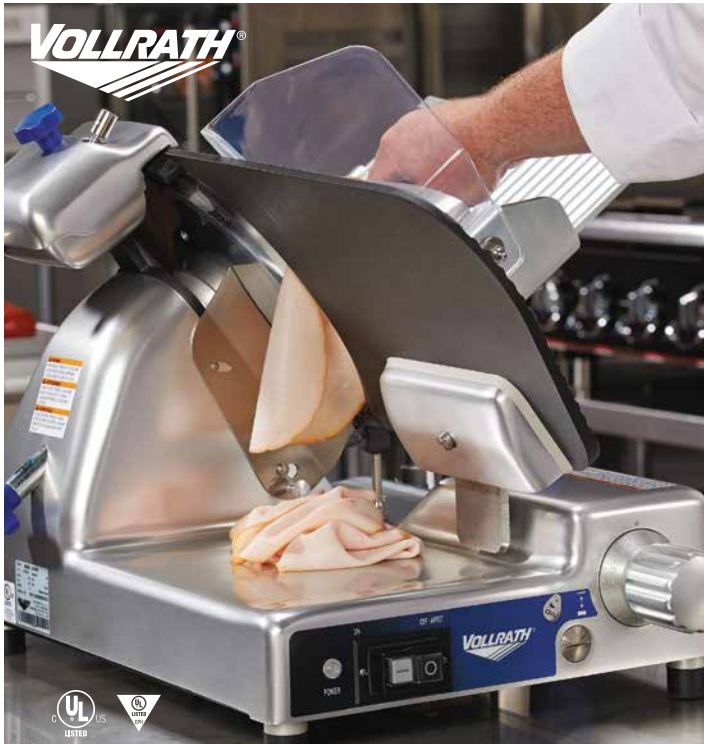

### Heavy-Duty Slicer

- Large receiving tray
- Safe blade removal tool
- Solid aluminum slice adjustment knob for precise and consistent slice thickness
- 35° gravity feed maximizes productivity by reducing operator fatigue and discomfort
- Permanent blade rim guard
- Removable carriage

40952 12" Blade, ½ hp

### Shredder/Slicer Attachments

- Highly polished precision machine aluminum housing
- All plates are stainless steel and are easy to mount, remove and clean
- Fits Hobart hub type power units

#### Grater/Shredder Attachment w/Disc Holder

UVS-9DHN #12  
UVS-922DHN #22

#### Vegetable Slicer Attachment w/"S" Knife

UVS-9SN #12  
UVS-922SN #22

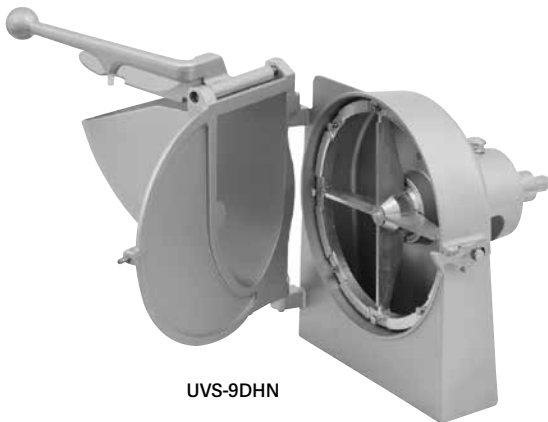

UVS-9DHN



40743



### Electric Meat Grinders

- Energy efficient motor and precision gear drive
- Supplied with ½" and ¾" grinder plates
- Sausage stuffer and feed stick accessories included
- Grinding head, pan, and attachments are dishwasher safe
- Stainless steel body, cylinder, worm gear, and ring

40743 #12 Grinds 264 lb/hour, 1 hp  
40744 #22 Grinds 528 lb/hour, 1½ hp



### Power Drive Units

- Powerful 1 HP fan-cooled motor
- Industry standard #12 attachment hub
- Brushed stainless steel construction with one-piece cast hub face
- Overload protection with manual reset button
- Non-scratch, non-slip feet
- 1 year parts and labor warranty
- 115V, 1 hp

GPD-L 200 RPM  
GPD-H 700 RPM



# SUPPLIER SPOTLIGHT



## Planetary Mixers

The perfect mix of performance, dependability and price!

- Gear-driven, high torque transmission
- Custom built motor
- Front mounted controls
- SP08 has 15 minute timer, 60-minute digital timer on 10 qt & larger mixers
- Heat-treated hardened steel alloy gears and shafts
- Rigid cast iron body (SP05 & SP08 are rigid cast aluminum)
- Stainless steel bowl guard (SP05 & SP08 have a polycarbonate splash cover)
- Includes stainless steel bowl, flat beater, wire whip and dough hook (SP60, SP80PL includes bowl truck; SP62P S/S bowl, dough hook & bowl truck)
- 2 year parts and labor warranty



Countertop Mixers	Capacity	Speeds	Motor
SP05	5 qt	10	800 watts
SP08	8 qt	3	¼ hp
SP10	10 qt	3	½ hp
Bench Mixers			
SP20	20 qt	3	½ hp
SP25	25 qt	3	¾ hp
Floor Mixers			
SP30	30 qt	3	1 hp
SP40	40 qt	3	2 hp
SP60	60 qt	3	3 hp
SP80PL	80 qt	4	3 hp
Pizza Mixers			
SP30P	30 qt	3	1½ hp
SP62P	60 qt	2	3 hp

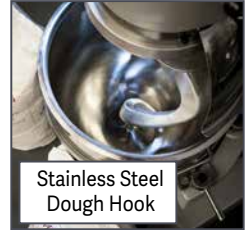

C12  
ETL Intertek

## ChefMate® by Globe Compact Manual Slicers

- For operations that slice one hour or less/day
- Anodized aluminum construction
- Removable top-mounted sharpener
- 0 to 3/16" slice thickness
- 1 year parts and labor warranty
- 115V

### C Models

- Hard chromed, special alloy hollow ground knife

### GC Model

- Stainless steel knife, food chute and slicer table



C9	9" Blade, ¼ hp
C10	10" Blade, ¼ hp
C12	12" Blade, ½ hp
GC512	12" Blade, ½ hp



G10  
ETL Intertek

## G Series Medium Duty Slicers

- Hard chromed, special alloy hollow ground knife
- Anodized aluminum construction
- Permanently attached knife ring guard
- Slices tissue thin to 3/16" thickness
- Extended rod, end weight and chute to accommodate product up to 10½" in length
- Full gravity feed food chute
- All metal knife sharpener
- 2 year parts and labor warranty



G10	10" Blade, ½ hp
G12	12" Blade, ½ hp
G12A	12" Blade, ½ hp, Auto
G14	14" Blade, ½ hp

## Planetary Mixers & Accessories

- Heavy-duty, precision crafted, versatile mixers are totally enclosed, permanently lubricated with a thermally protected motor
- Gear driven and has 3 pre-selected fixed speeds
- #12 taper hub front port
- Planetary mixing-action consistently blends, mixes and aerates all ingredients with satisfactory results
- Equipped with overload switch to protect the motor
- Heat treated carbon steel gears are fully sealed to allow durability and dependability with quiet operation
- A hardened steel worm and alloy bronze worm gear transmit power from motor to transmission
- Manual bowl lift is lever operated and self-locking in top position

- The stainless steel, wire front bowl guard opens easily for adding ingredients
- The safety guard prevents the unit from running if it is opened
- Includes S/S Bowl, Spiral Dough Hook, Flat Beater, and S/S Wire Whip
- 110V

Uniworld Mixer attachments also available. 

UPM-10E	10 qt, ½ hp
UPM-20E	20 qt, 1 hp
UPM-30E	30 qt, 2 hp

**UNIWORLD**

### Hobart Compatible Mixer Attachments\*

UM-20FB	Flat Beater for 20 qt Mixer	UM-30WW	S/S Wire Whip for 30 qt Mixer
UM-30FB	Flat Beater for 30 qt Mixer	UM-20B	Mixing Bowl for 20 qt Mixer
UM-20DH	Spiral Dough Hook for 20 qt Mixer	UM-30B	Mixing Bowl for 30 qt Mixer
UM-30DH	Spiral Dough Hook for 30 qt Mixer	UBT223	Bowl Dolly/Truck fits 60, 80 & 140 qt Bowls
UM-20WW	S/S Wire Whip for 20 qt Mixer		

\* Attachments also available for 60, 80 & 140 qt mixers



SUPPLIER SPOTLIGHT

## Planetary Mixer

- Includes S/S mixing bowl, wire whisk, dough hook, spatula and safety guard
- 30 min timer stops the mixer when the timer ends
- 3 speed gear transmission
- Safety cutoff switch automatically turns the unit off if gears are changed without stopping the mixer
- #12 hub
- 110V
- 2 year parts and 1 year labor warranty, 5 year warranty on belt

40757 20 qt Mixer

**VOLLRATH®**



 10, 30, 40 & 60 quart models also available.

## Food Prep Machine

- Made of cast aluminum, discs are made of stainless steel
- Grates cheese, cuts, slices, and shreds vegetables
- Magnetic cut-off switch
- 2 different feeders to cut food in different shapes, includes 2 slicing disks and a shredding disk
- 110/60/1, ¾ hp, 270 Disc RPM

FP-300A 22"l x 10½"w x 19"h



**UNIWORLD**

# SUPPLIER SPOTLIGHT

## Citrus Juicer

- Cast aluminum base with acid-resistant finish
- Extra-large stainless steel bowl
- Durable, polyacetal copolymer strainer
- 3 reinforced reamer sizes
- Each reamer has a stainless steel insert for long-term heavy-duty use
- Sealed on/off push button switch
- 2 year parts and labor ExpressCare Replacement Warranty

HCJ967 10¼" w x 10" d x 18½" h



## Manual Citrus Juicer

- Acid-resistant enamel and chrome finish
- Rack and pinion gearing
- 2000 lb pressure
- Heavy-duty gears for years of durability
- Maximum juice extraction with minimum pulp and skin oil
- Swing-out juice collector cup
- Removable strainer cone and funnel
- Sure Grip™ feet prevent skidding
- 1 year warranty

932 7" w x 9" d x 19½" h



## Citrus Juicer

- Heavy-duty, die-cast aluminum housing
- Long-lasting induction motor
- 6" high cup clearance
- 3 sizes of stainless steel reinforced reamers
- Removable bowl, strainer, and splash guard
- Illuminated on/off switch
- Tray removes to fit taller juice glasses
- 120V
- 1 year warranty

66900 8.6" w x 12.5" d x 16.1" h



## Otto™, The Juice Extractor

- Powerful, yet quiet brushless induction motor with dual cooling fans designed for continuous use
- Large, 3" feed chute reduces prep time
- Unique, funnel-shaped spout reduces juice splashes and drips
- Heavy-duty metal handle with safety lid-interlock
- Brushed stainless steel bowl
- Die-cast aluminum base
- Ergonomic Tritan™ food pusher
- Tritan™ BPA-free plastic lid
- Oversized, nonskid drip tray fits cups and blender jars
- Easy to take apart and clean
- 2 year parts & labor ExpressCare Replacement Warranty

HJE960



Ready to learn more about these great products?  
**PLAY VIDEO**

## Commercial Wheatgrass Juicer

- 304 grade stainless steel construction
- Extracts up to 150ml/minute compared to 60–100ml/minute models
- ½ hp, 70 rpm air-cooled motor for years of high volume usage
- Positive interlocking head system with adjustable resistance screw
- Forward and reverse motor operation
- Includes 2 screens, 2 gaskets, custom wrench, and wheatgrass pusher
- 1 year ExpressCare Replacement Warranty

HWG800 7" w x 19¼" d x 12" h



## Juice Extractor

- Ideal for anywhere juice is served
- Provides quiet and continuous juice production with an automatic pulp extractor
- Cast aluminum and stainless steel construction
- Automatic pulp extractor
- This unit features an adjustable spout (8 different positions) for convenient placement
- Simple and safe to operate
- Easy to dismantle for cleaning
- 1 hp, 3450 RPM

UJC-750E 17" l x 12" w x 19½" h





## Tomato Slicers

- Push handle features extra safety loop handle and thumb grip
- Green cutting board complies with Serv-Safe and local health department requirements
- Easy carry top handle
- Easy replacement blades
- 2 safety stops in key areas



SLT1 ¼" Cut Size  
SLT2 ⅜" Cut Size

**CRESTWARE**

## Immersion Blenders

- Removable stainless steel blending sticks and blades
- Variable speed, heavy-duty motor
- Interlocked power switch
- Overload protection
- 7½' power cord
- 1 year replacement warranty



	Watt	Blending Stick
GIB500-12	500	12"
GIB750-14	750	14"
GIB750-16	750	16"
GIB750-18	750	18"
GIB750-22	750	22"



GIB500-12



## Mix 'N Chill Commercial Drink Mixer

- ¾ hp power motor provides heavy-duty mixing action for shakes and candy mix ins
- Stainless steel shaft and agitator
- Rotary dial with variable speed control
- Removable splash pan and splash guard for easy cleaning
- Unit comes with base, spindle, splash shield, and Sure Grip Feet
- 1 year parts & labor Expresscare Replacement warranty



94950

10" w x 8¾" d x 25¾" h

## Expeditor™ Culinary Blenders

- Blend, puree, grind, chop and emulsify
  - Adjustable speed dial for variable speed functions (excluding HBF900S)
  - Lifetime warranty on all-metal drive coupling and stainless steel blades
  - Includes base, stackable container, dosing cup and lid
  - 120V
  - 3 year parts and labor warranty, 2 year Expresscare Replacement warranty
  - Lifetime warranty on motor drive and blades (HBF600, HBF600S, HBF900S, and HBF1100S)
- Models HBF500 and HBF500S:
- Wave-Action System™
  - 2 year parts & labor Expresscare Replacement warranty
- Models HBF600 and HBF600S:
- One-touch chopping, temperature gauge, jar pad sensor
- Model HBF900S:
- 3 speeds: Low, Med, High
- Model HBF1100S:
- Memory card for programming, temperature gauge, illuminated power light, preset timer button, weighted die-cast aluminum base



Ready to learn more about these great products?  
**PLAY VIDEO**



## Spindle Drink Mixers

- Ideal for high volume milk shakes, flashing bar drinks, blending eggs, pancake and waffle batters
- Two way motor activation with cup guide or toggle switch
- Removable cup guides pull out for easy cleaning
- 3 separate motors work independently with individual power switch (HMD400)
- Precision motors are balanced to minimize vibration, built to last with sealed, permanently lubricated ball bearings
- Stainless steel construction and agitator
- 3 speed toggle switch per spindle
- Automatic motor activation
- Stabilizer arm and Sure Grip™ feet
- Malt cup(s) included
- 1 year parts & labor warranty



HMD200 Single  
HMD400 Triple



HBF600S



HBF1100S

w/Stainless Steel Container

	Capacity	Control	HP
HBF500S	64 oz	Toggle	1
HBF600S	64 oz	Touchpad	3
HBF900S	1 gal	Rocker Switch	3½
HBF1100S	1 gal	Touchpad	3½

w/Polycarbonate Container

	Capacity	Control	HP
HBF500	48 oz	Toggle	1
HBF600	64 oz	Touchpad	3

# SUPPLIER SPOTLIGHT

## Heavy-Duty Stainless Steel Basting Spoons w/Ergo Grip™ Handles

- One-piece stainless steel construction is extremely durable and has no crevices to collect water or bacteria
- High-temperature patented nylon handles are heat resistant to 450°F
- Handle contains an all natural antimicrobial material
- Built-in stopper notch
- 3-sided spoons have one straight edge for cutting
- Lifetime warranty



	Black	White	Blue	Red	Yellow	Green	Length
Solid	64130	6414015	6414030	6414040	6414050	6414070	13 <sup>3</sup> / <sub>16</sub> "
Perforated	64132	6414215	6414230	6414240	6414250	6414270	13 <sup>3</sup> / <sub>16</sub> "
Slotted	64134	—	—	—	—	—	13 <sup>3</sup> / <sub>16</sub> "
3-Sided Solid	64136	—	—	—	—	—	13 <sup>3</sup> / <sub>16</sub> "
3-Sided Perforated	64138	—	—	—	—	—	13 <sup>3</sup> / <sub>16</sub> "



## One-Piece Heavy-Duty Ladles w/Color-Coded Kool-Touch® Handles

- Accurate bowl dimensions ensure consistent capacities
- Capacities clearly stamped on product for easy identification
- Handles contain an all natural antimicrobial material
- Lifetime warranty



	Color	Capacity	Bowl Dia	Handle Length
4980120	Black	1 oz	1 <sup>3</sup> / <sub>4</sub> "	9 <sup>7</sup> / <sub>8</sub> "
4980230	Blue	2 oz	2 <sup>3</sup> / <sub>8</sub> "	9 <sup>7</sup> / <sub>8</sub> "
4980335	Ivory	3 oz	2 <sup>7</sup> / <sub>8</sub> "	12 <sup>5</sup> / <sub>8</sub> "
4980445	Gray	4 oz	3 <sup>3</sup> / <sub>8</sub> "	12 <sup>5</sup> / <sub>8</sub> "
4980655	Teal	6 oz	3 <sup>1</sup> / <sub>2</sub> "	12 <sup>3</sup> / <sub>8</sub> "
4980865	Orange	8 oz	4"	12 <sup>5</sup> / <sub>8</sub> "

## Cutlery

- High carbon German steel blades
- Polypropylene handles



- A. KN01 Peeling Knife, 2<sup>3</sup>/<sub>4</sub>"
- B. KN02 Paring Knife, 3<sup>1</sup>/<sub>2</sub>"
- KN04 Paring Knife, Twin Pack, 3<sup>1</sup>/<sub>2</sub>"
- C. KN03 Paring Knife, Serrated, 3<sup>1</sup>/<sub>2</sub>"
- D. KN06 Utility Knife, Serrated, 4<sup>1</sup>/<sub>2</sub>"
- E. KN42 Utility Knife, 9"
- F. KN40 Boning Knife, 6"
- G. KN41 Boning Knife, Curved, 6"
- H. KN60 Cleaver, 6"
- I. KN61 Santoku, Granton, 7"
- J. KN30 Cook's Knife, 8"
- KN31 Cook's Knife, 10"
- KN32 Cook's Knife, 12"
- K. KN20 Offset Bread Knife, 9"
- L. KN21 Bread Knife, Curved, 10"
- M. KN22 Bread Knife, Straight, 10"
- N. KN50 Slicer, 10"
- KN52 Slicer, 12"
- O. KN51 Slicer, Serrated, 10"
- KN53 Slicer, Serrated, 12"



## CRESTWARE

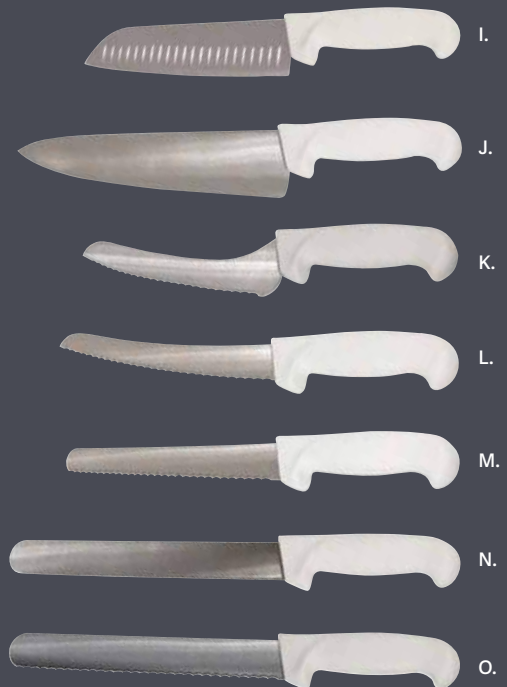



## StorPlus™ Food Pans & Lids

- Polycarbonate construction resists food acids and oils
- Easy and safe to use and clean
- Clear polycarbonate tolerates -40° to 212°F
- Reinforced corners
- Spoonable bottoms
- Capacity indicators in both quarts and liters
- Dishwasher safe
- Colors: Clear (07), Black (03)



SUPPLIER SPOTLIGHT



### Smart Lids™

- Polycarbonate
- Withstands high heat
- Unique inside seal design provides superior leak-resistance and keeps your food fresher, longer
- Blue



### EZ Access Hinged Universal Lids

- Allows people to serve themselves, without having to hold the lid open
- Withstands temperatures between -40° to 212°F
- Peg hole and handle for easy gripping
- Polycarbonate withstands tough use and resists food acids and oils



### Universal Lids

- Clear polycarbonate
- Fits Carlisle food pans as well as other major brands on the market
- Available in standard sizes
- Stack with themselves for easy storage
- Dishwasher safe
- High heat lids are also available – ask your salesperson for details

#### Full Size - 20¾" x 12¾"

- 10200B 2½" deep
- 10201B 4" deep
- 10202B 6" deep
- 10203B 8" deep
- 10210U Universal Handled Lid
- 10211U Universal Handled Lid, Notched
- 10216U Universal Flat Lid
- 10217U Universal Flat Lid, Notched
- 10215 Drain Shelf

#### Half Size Long - 20¾" x 6¼"

- 10240B 2½" deep
- 10241B 4" deep
- 10250U Universal Handled Lid
- 10256U Universal Flat Lid
- 10257U Universal Flat Lid, Notched

#### Half Size - 12¾" x 10⅞"

- 10220B 2½" deep
- 10221B 4" deep
- 10222B 6" deep
- 10223B 8" deep
- 10230U Universal Handled Lid
- 10231U Universal Handled Lid, Notched
- 10236U Universal Flat Lid
- 10237U Universal Flat Lid, Notched
- 10235 Drain Shelf

#### Third Size - 12¾" x 7"

- 30660 2½" deep
- 30661 4" deep
- 30662 6" deep
- 30669 8" deep
- 10270U Universal Handled Lid
- 10271U Universal Handled Lid, Notched
- 10276U Universal Flat Lid
- 10277U Universal Flat Lid, Notched
- 10278Z EZ Access Hinged Lid
- 10279Z EZ Access Hinged Lid, Notched
- 10280Z EZ Access Hinged Lid w/2 Notches
- 30580 Smart Lid™
- 30670 Drain Shelf

#### Quarter Size - 10¼" x 6⅝"

- 30680 2½" deep
- 30681 4" deep
- 30682 6" deep
- 10290U Universal Handled Lid
- 10291U Universal Handled Lid, Notched
- 10296U Universal Flat Lid
- 10297U Universal Flat Lid, Notched
- 30581 Smart Lid™
- 30695 Drain Shelf

#### Sixth Size - 6¾" x 6⅝"

- 30683 2½" deep
- 10310U Universal Handled Lid
- 10311U Universal Handled Lid, Notched
- 10316U Universal Flat Lid
- 10317U Universal Flat Lid, Notched
- 10318Z EZ Access Hinged Lid
- 10319Z EZ Access Hinged Lid, Notched

#### Smart Lid™

#### Drain Shelf

#### Ninth Size - 6¾" x 4¼"

- 30686 2½" deep
- 30687 4" deep
- 30688 6" deep
- 10336U Universal Flat Lid
- 10337U Universal Flat Lid, Notched
- 30583 Smart Lid™



# SUPPLIER SPOTLIGHT

## StorPlus™ Food Storage Boxes & Lids

- Clear polycarbonate provides easy visibility, superior resistance to food acids and oils
- Reinforced top and bottom corners on both box and lid
- Withstands temperatures from -40° to 212°F
- Easy grip handles
- Smooth interior surface
- Dishwasher safe

10610	Box, 12" x 18" x 3½"	10622	Box, 18" x 26" x 9"
10611	Box, 12" x 18" x 6"	10623	Box, 18" x 26" x 12"
10612	Box, 12" x 18" x 9"	10624	Box, 18" x 26" x 15"
10617	Lock Tight Lid, 12" x 18"	10627	Lock Tight Lid, 18" x 26"
10620	Box, 18" x 26" x 3½"	10628	Colander, 18" x 26" x 5"
10621	Box, 18" x 26" x 6"		



## StorPlus™ Square Food Storage Containers & Lids

- Capacity indicators are listed in both quarts and liters, and are color coded to match lids for quick identification
- Polycarbonate withstands temperatures from -40° to 212°F
- White polyethylene withstands temperatures from -40° to 180°F
- Dishwasher safe
- Colors: Clear Polycarbonate (07); White Polyethylene (02)



Containers		Capacity	Graduation	
Clear	White		Color	
10720	10730	2 qt	Forest Green	
10721	10731	4 qt	Forest Green	
10722	10732	6 qt	Red	
10723	10733	8 qt	Red	
10724	10734	12 qt	Blue	
10725	10735	18 qt	Blue	
10726	10736	22 qt	Blue	

Lids (fit both Clear & White containers)	
10740	Fits 2-4 qt, Forest Green (08)
10741	Fits 6-8 qt, Red (05)
10742	Fits 12, 18 & 22 qt, Blue (60)



## Food Storage Containers & Lids

- Square shape allows for practical storage
- Molded-in volume graduations indicate capacity
- Translucent polypropylene containers withstand temperatures from 32° to 170°F
- Economical White polyethylene containers withstand temperatures from -40° to 180°F
- Dishwasher safe
- Colors: Translucent Polypropylene (30), White Polyethylene (02)

Containers		
Translucent	White	Capacity
ST1532	1532	2 qt
ST1544	1544	4 qt
ST1556	1556	6 qt
ST1568	1568	8 qt
ST1629	1629	18 qt

Lids (all containers use Translucent Polypropylene lids)	
ST1573	Fits 2-4 qt Containers
ST1587	Fits 6-8 qt Containers
ST1630	Fits 18 qt Containers



## Optio™ Fry Pans

- High chrome construction distributes heat quickly and will not pit, discolor or carry flavors
- Aluminum-clad bottom provides quick and even distribution of heat
- Clad bottom is encapsulated by stainless steel to prevent denting and scratching
- Induction ready
- Made without PFOA

Natural Finish		Non-Stick Finish	
3808	8" dia	N3808	8" dia
3809	9½" dia	N3809	9½" dia
3811	11" dia	N3811	11" dia



## Heavy Gauge Aluminum Sauce Pans

- 3003 aluminum
- Covers sold separately
- Grip handles are heat resistant up to 350°F

Plain Handle	Grip Heat Handle	Capacity	Cover	Plain Handle	Grip Heat Handle	Capacity	Cover
PAN1	PAN1H	1½ qt	PANC1	PAN5	PAN5H	5½ qt	PANC5
PAN2	PAN2H	2½ qt	PANC2	PAN7	PAN7H	7 qt	PANC7
PAN3	PAN3H	3½ qt	PANC3	PAN8	PAN8H	8½ qt	PANC8
PAN4	PAN4H	4½ qt	PANC4	PAN10	PAN10H	10 qt	PANC10



## Extra Heavy Weight Aluminum Braziers w/ Covers

- ¼" thick
- 3003 aluminum
- Covers included

	Capacity		Capacity
BZR05	5 qt	BZR25	25 qt
BZR10	10 qt	BZR30	30 qt
BZR15	15 qt	BZR35	35 qt
BZR20	20 qt	BZR40	40 qt

## Aluminum Fry Pans

- 3004 aluminum
- Molded handle is heat resistant to 450°F
- Non-tip design
- Best coatings available
- Heavy 3-rivet design



- 'Black Pearl' Anodized
- Teflon™ PlatinumPro coating
- Molded handle

FRY07AXH	7½" dia
FRY08AXH	8½" dia
FRY10AXH	10¾" dia
FRY12AXH	12¾" dia
FRY14AXH	14¾" dia

### Heavy Weight Polished

Plain Handle	Molded Handle		
FRY07	FRY07H	7½" dia	
FRY08	FRY08H	8½" dia	
FRY10	FRY10H	10¾" dia	
FRY12	FRY12H	12¾" dia	
FRY14	FRY14H	14¾" dia	

### Teflon™ Xtra Coating

Plain Handle	Molded Handle		
FRY07S	FRY07SH	7½" dia	
FRY08S	FRY08SH	8½" dia	
FRY10S	FRY10SH	10¾" dia	
FRY12S	FRY12SH	12¾" dia	
FRY14S	FRY14SH	14¾" dia	

# SUPPLIER SPOTLIGHT

## Aluminum Pasta Cookers

- Stock pot and perforated insert with a formed shoulder
- Handles are fastened with rivets
- Cover fits both pot and inset

### One Compartment Cookers

PASTA12	12 qt, 3 Piece Cooker
PASTA20	20 qt, 3 Piece Cooker

### Four Compartment Cookers

PASTA20D	20 qt, Complete
PASTA20I	Stainless Inset Only

PASTA12

PASTA20D

## Double Boilers

- Heavy weight aluminum
- Complete with pot, inset and cover

	Size	Inset Capacity
DBL08	8 qt	6½ qt
DBL12	12 qt	11 qt
DBL16	16 qt	14 qt
DBL20	20 qt	17½ qt



## Steamer Baskets

BSK20	Fits 20 qt Pot
BSK30	Fits 30 qt Pot
BSK40	Fits 40 qt Pot
BSK50	Fits 50 qt Pot
BSK60	Fits 60 qt Pot
BSK80	Fits 80 qt Pot

## Heavy-Duty Stock Pots

- 5mm thick to withstand heavy use
- 3003 aluminum
- Covers sold separately

HPOT20	20 qt
HPOT30	30 qt
HPOT40	40 qt
HPOT60	60 qt



## CRESTWARE

## Aluminum Sauce Pots & Covers

- 3003 aluminum
- Covers sold separately



	Capacity	Cover		Capacity	Cover
SAU5	5 qt	SAUC5	SAU28	28 qt	SAUC28
SAU8	8 qt	SAUC8	SAU33	33 qt	SAUC33
SAU18	18 qt	SAUC18	SAU42	42 qt	SAUC42
SAU24	24 qt	SAUC24	SAU60	60 qt	SAUC60

## Aluminum Stock Pots & Covers

- 3003 aluminum
- Reinforced rim
- Anti-slip handle
- Consistent thickness
- Covers sold separately
- 80 to 160 qt pots are 5mm thick

Capacity	Cover	Capacity	Cover
POT08	8 qt	POTC08	POTC50
POT12	12 qt	POTC12	POTC60
POT16	16 qt	POTC16	POTC80
POT20	20 qt	POTC20	POTC100
POT24	24 qt	POTC24	POTC120
POT30	32 qt	POTC30	POTC160
POT40	40 qt	POTC40	
		POT50	
		POT60	
		POT80	
		POT100	
		POT120	
		POT160	

Constructed of pressed, not spun aluminum, giving a more even and faster heating time





Adjustable neck with grommet and chest pocket

ALWAQ024

ABAQ054



Adjustable cross-back ties with snap tab

ABX01



AWN01



APKBL

### Dorset Aprons

- 7.8 oz 100% cotton
- Antique washed finish
- Cell phone and notebook pockets with riveted ends
- One size fits most



ABAQ054 Bib Apron, 34"l x 30"w  
 ABCAQ004 Chef's Bib Apron, 40"l x 39"w  
 ALWAQ024 Bistro Apron, 31"l x 31"w  
 AHWAQ014 Half Bistro Apron, 19"l x 31"w

### Uptown Aprons

- 9.3 oz 75/25 cotton/poly textured crosshatch denim with artisan finish
- 3-part front pocket and cell phone pocket



ABX01 Cross-Back Bib Apron, 34"l x 30"w  
 AHN01 Half Bistro Apron, 18"l x 31"w  
 AWN01 Waste Apron, 12"l x 23"w

### Bib Apron

- Poly/cotton
- Soil release finish
- No pockets
- 33" x 28"

APKBL Black  
 APKDC White



### Boulder Aprons

- 10.8 oz 100% cotton denim with a waxed finish look
- Towel loop
- Reverse fabric ties
- Reinforced stress points
- Chefs apron features a tweezer chest pocket
- Double front pockets
- Available in Brown/Black (BNB) and Purple/Black (PUB)



ABCWT001 Chef's Bib Apron, 34"l x 30"w  
 ABWT051 Bib Apron, 18"l x 31"w  
 AHWWT001 Half Bistro Apron, 12"l x 23"w  
 ALWWT021 Bistro Apron, 12"l x 23"w



### Waist Apron

- 6.2 oz 65/35 poly/cotton
- 3 part pouch pockets
- See color options below

F9 12" x 23"



Additional colors available - please contact your local sales representative for details.

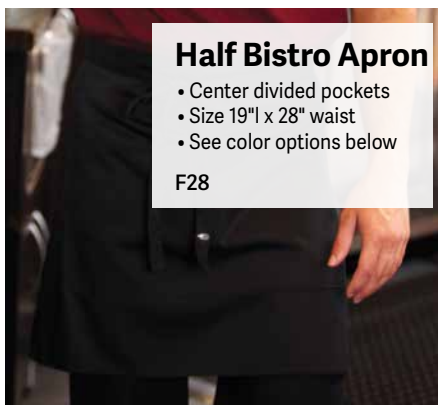

### Half Bistro Apron

- Center divided pockets
- Size 19"l x 28" waist
- See color options below

F28



Adjustable neck with overall clips

ABWT051



AHWWT001

# SUPPLIER SPOTLIGHT

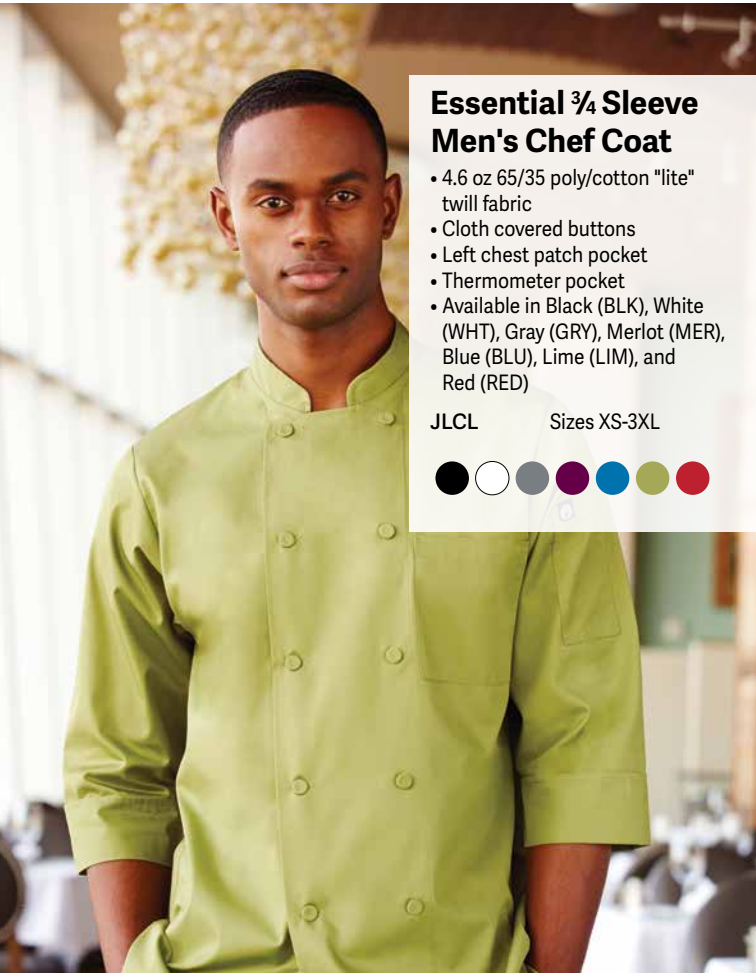

## Essential 3/4 Sleeve Men's Chef Coat

- 4.6 oz 65/35 poly/cotton "lite" twill fabric
- Cloth covered buttons
- Left chest patch pocket
- Thermometer pocket
- Available in Black (BLK), White (WHT), Gray (GRY), Merlot (MER), Blue (BLU), Lime (LIM), and Red (RED)

JLCL Sizes XS-3XL



## Essential Baggy Chef Pants

- 65/35 poly-cotton blend
- Two seam pockets, one back pocket
- Tapered legs
- Elastic waist with drawstring
- XS-4X

NBBP Black  
NBCP Small Check

## Cool Vent™ Beanies

- Two-way technology moves moisture away from the body while allowing cool air to filter back in
- One size fits most

DFBB Black  
DFWB White



## Springfield Chef Coats

- 4.6 oz 65/35 poly/cotton 'lite' twill fabric
- Cool Vent sides
- Short-sleeve
- Single-breasted
- Sizes XS-3XL
- Available in Gray (GRY), Purple (PUR), Black (BLK) and White (WHT)

BCWSZ006 Women  
BCSZ009\* Men

\*Also available in Brick (BRI), Ink Blue (INB) and Sky Blue (SKY)

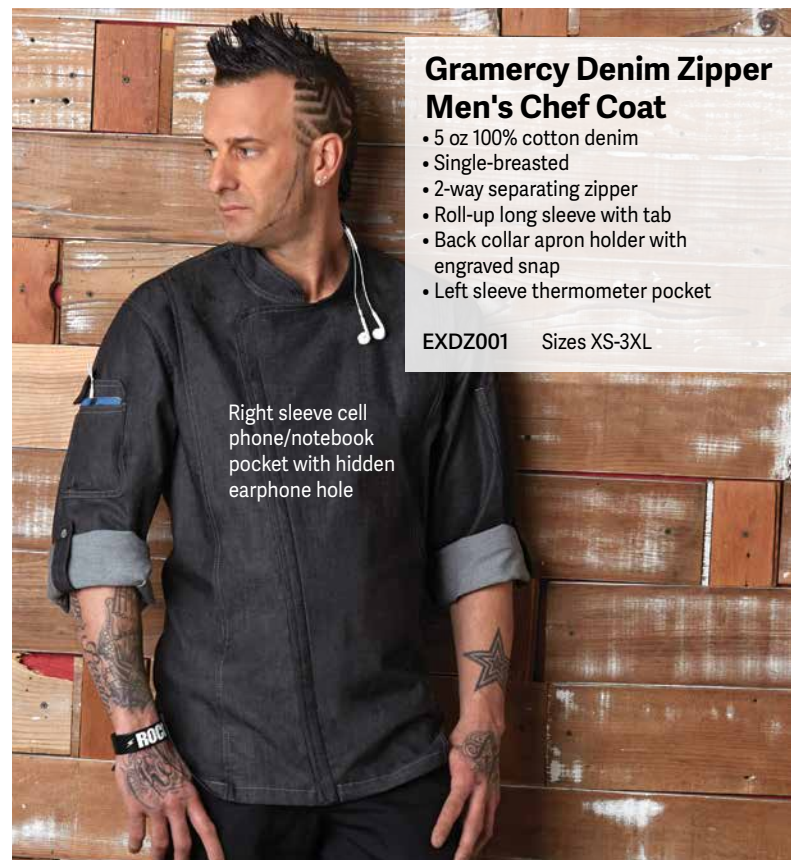

## Gramercy Denim Zipper Men's Chef Coat

- 5 oz 100% cotton denim
- Single-breasted
- 2-way separating zipper
- Roll-up long sleeve with tab
- Back collar apron holder with engraved snap
- Left sleeve thermometer pocket

EXDZ001 Sizes XS-3XL

Right sleeve cell phone/notebook pocket with hidden earphone hole





### Lansing Women's Chef Coat

- 4.7 oz. 65/35 poly/cotton 'lite' twill fabric
- Cool Vent™ back/side panels
- Roll-up long sleeve with tab
- Side seam slits
- Concealed snap front
- Left sleeve thermometer pocket

BCWMC007 Sizes XS-3XL



### Montreal Men's Chef Coat

- 4.6 oz poly/cotton "lite" fabric
- Cool Vent™ back inlay
- Cloth-covered buttons
- Left patch pocket
- Thermometer pocket
- Available in Black (BLK) or White (WHT)

JLCV Sizes XS-3XL



Single-breasted with 2-way separating zipper

Cool Vent

### Hartford Men's Chef Coat

- 4.7 oz 65/35 poly/cotton 'lite' fabric
- Cool Vent™ sides and side seam slits
- Roll-up long sleeve with tab
- Back collar apron holder
- Thermometer and cell phone/notebook pocket
- Available in Black (BLK), Blue (BLU), Graphite Gray (GHG), Gray (GRY) or White (WHT)

BCLZ008 Sizes XS-3XL

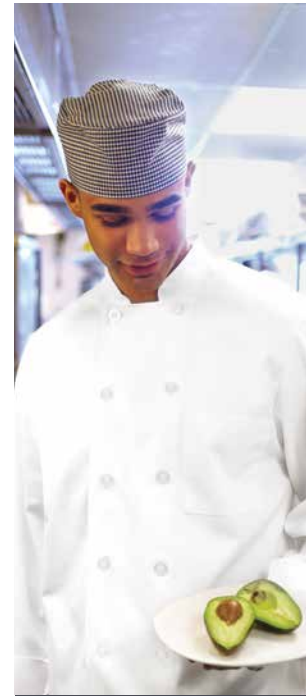

### Le Mans Basic Chef Coat

- 65/35 poly-cotton
- Left breast pocket and thermometer pocket
- Matching buttons
- Turned-back cuff

WCCW Sizes XS-8XL



### Bordeaux Basic Chef Coat

- Poly-cotton
- Left breast pocket and thermometer pocket
- Cloth-knot buttons
- Turned-back cuff

PKWC XS-6XL



### Volnay Basic Chef Coat

- Poly cotton
- Left breast pocket
- Short sleeve
- Pearl buttons

PCSS XS-4XL

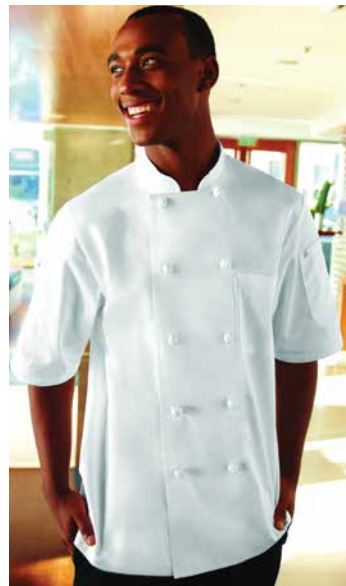

### Tivoli Basic Chef Coat

- Poly-cotton
- 6.3 oz fabric
- Short sleeve
- Left patch pocket and thermometer pocket
- Cloth-knot buttons

KNSS XS-XL



### Cool Vent™ Cook Shirt

- Poly-cotton blend
- Cool Vent™ panel under sleeve & down sides
- Pearl buttons
- Patch pocket
- Available in Black or White

CSCV Sizes XS-3XL

# SUPPLIER SPOTLIGHT

## Stainless Steel Cabinets

- All stainless steel construction
- Sliding doors
- Available with or without a middle shelf
- 6" legs



## Dish Cabinets

- 18 gauge stainless steel with 1½" edge 95° turn
- Two stainless steel shelves, 12" apart
- 35" working height
- 6" legs

DC-1536	15" x 36"
DC-1548	15" x 48"
DC-1560	15" x 60"
DC-1572	15" x 72"



w/o Backsplash	w/Backsplash	W x L
CB-2448	BCB-2448	24" x 48"
CB-2460	BCB-2460	24" x 60"
CB-2472	BCB-2472	24" x 72"
CB-3036	BCB-3036	30" x 36"
CB-3048	BCB-3048	30" x 48"
CB-3060	BCB-3060	30" x 60"
CB-3070	BCB-3070	30" x 70"



Ready to learn more about these great products?

**PLAY VIDEO**



# AERO...

## Quality You Can Trust!

The industry leader in stainless steel customized equipment.



All custom made by Union Craftsmen in the USA.



## Bussing Carts & Accessories

- Elegant styling is perfect for front of house serving, bussing, or even room service applications
- Durable construction will stand up to the toughest use
- Sturdy, textured shelves with raised edges
- Side panels help hide clutter
- 4" heavy-duty non-marking swivel casters
- Convenient knockdown design is easy to assemble
- 300 lb capacity

CC2036 Bussing Cart, 18" x 36"  
CC2243 Bussing Cart, 42" x 23"

CC11TH Trash Bin (not shown)  
CC11SH Flatware Bin (not shown)



SBC1521

## Fold 'N Go® Carts

- Folds and unfolds in one easy motion
- Durable construction, 3/4" solid aluminum legs add strength and rigidity
- Sturdy polyethylene shelves
- Ships fully assembled
- Up to 350 lb capacity
- Shelf colors: Black (03) and Dove Gray (23)

SBC1521 15" x 21"  
SBC2031 20" x 31"



## 3-Tier Carts

265 lb load capacity

- Extra durable poly
- Shipped knocked down - easy to assemble

RTROLLEY Regular, 36"l x 16 1/2"w x 24 1/2"h, Gray  
RBTROLLEY Regular, 36"l x 16 1/2"w x 24 1/2"h, Black  
LTROLLEY Large, 37"l x 19 1/2"w x 31"h, Gray  
LBTROLLEY Large, 37"l x 19 1/2"w x 31"h, Black  
RTB Refuse and Silverware Bin Set



RTROLLEY  
Shown with  
refuse and  
silverware bins

## CRESTWARE



## Heavy-Duty Bus Tubs & Lids

- Durable plastic
- Stackable with handles
- Ribbed interior surface
- 20 1/2" x 15 1/2"
- Colors: Black (BK), Brown (BR), Gray (GY) and White (WH)

BT5 5"d  
BT7 7"d  
BTLID Fits BT5 & BT7

# SUPPLIER SPOTLIGHT

## Dish Racks & Extenders

- Available open or with compartment dividers
- Compartment racks include full-height dividers and may be used with extenders
- Rack extenders are durable strong, and feature permanent, easy clip installation



## Dish Rack Dolly

- Extra thick base and heavy-duty casters
- Makes transporting dish racks quick, easy and safe

RDOLLY2 Rack Dolly w/Casters  
RHANDLE Handle for Rack Dolly



**CRESTWARE**

### Compartment Racks

RBC9 9-Compartment Rack Base  
RBC16 16-Compartment Rack Base  
RBC20 20-Compartment Rack Base  
RBC25 25-Compartment Rack Base  
RBC36 36-Compartment Rack Base  
RBC49 49-Compartment Rack Base

### Plate and Tray Racks

RBPT Plate & Tray Rack, Closed End  
RBPTO Plate & Tray Rack, Open End  
RBOC Open Cup Rack

### Cutlery Racks

RBFS Rack Base for Flatware  
RCH Cutlery Holders

### Rack Extenders

REO Open Rack Extender  
REC9 9-Compartment Rack Extender  
REC16 16-Compartment Rack Extender  
REC20 20-Compartment Rack Extender  
REC25 35-Compartment Rack Extender  
REC36 36-Compartment Rack Extender  
REC49 49-Compartment Rack Extender

**CARLISLE**  
FOODSERVICE PRODUCTS

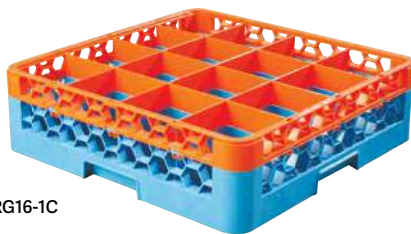

RG16-1C



NeWave™ glass racks reduce storage space, labor, needed rack inventory & chemical usage by up to 20%

Other sizes and accessories available, please contact your local sales representative for details.



RP

## OptiClean™ Racks

- Open construction allows maximum exposure to cleaning spray; full dividers in the base offer complete protection for delicate rims
- Quick draining – no flat surfaces to trap water or loose food particles
- Comfort Curve™ handles for easy handling



RW20-1

### Glass Racks

RG9-3 9-Compartment, 3 Extenders, 5 1/16" x 5 1/16"  
RG16-1C 16-Compartment w/1 Extender  
RG25 25-Compartment  
RG25-1C 25-Compartment w/1 Extender  
All Purpose Peg Rack  
RP Full Size, 1/4" Peg Size

- Color: Blue (14)
  - 19 3/4" x 19 3/4" outside measurement
- OptiClean™ NeWave™ Glass Racks**
- Compartment sizes are designed to fit the most popular sizes of glasses and tumblers

### NeWave™ Glass Racks

**20 Compartment-Holds Glasses Up to 3 3/8" dia**  
RW20 20-Compartment w/Integrated Extender  
RW20-1 20-Compartment w/2 Extenders  
**30 Compartment-Holds Glasses Up to 3 3/8" dia**  
RW30 30-Compartment w/Integrated Extender  
RW30-1 30-Compartment w/2 Extenders  
RW30-2 30-Compartment w/3 Extenders  
RW30-3 30-Compartment w/4 Extenders



Automatic Drain



### Hi-Temp Rack Conveyor Dishwasher

- 209 racks per hour
- Perpetual rack advance system, with intuitive jam alert, and drive protection
- Proportional rinse, delivering unmatched total ware coverage, utilizing digital pattern cloning, stainless steel nozzles
- 100 GPH with energy sentinel (idle pump shut-off)
- Prodigy series HMI display, intuitive condition alerts, with user friendly cleaning and operation visual guidance, multi-lingual, touch control
- Programmable machine dwell with automatic rack alignment into the optimal wash zone
- Single-piece stainless steel upper and lower wash arm manifolds
- Stainless steel heavy gauge construction including base, legs and feet
- 20" standard vertical clearance to accommodate 18" x 26" sheet pans
- 2 hp pump motor, with stainless steel impeller
- 1 year parts and labor warranty
- Made in USA

44 PRO 44"w x 25¾"d x 58¾"h

### Hi-Temp Door-Type Dishwasher

- 40 racks per hour
- Ventless heat recovery
- HMI – Operator Touch Screen Interface
- Field convertible
- Sleep Mode - All internal heaters shut off after 4 hours idle
- Door Interlock locks door closed during the vent fan cycle
- Built-in booster configured to ensure 180°F rinse
- Field convertible from straight to corner operation
- Rinse Sentry ensures 180°F final rinse
- Auto start starts unit when hood is closed
- High efficiency 2 hp pump
- Self draining pump
- 4 selectable cycles
- 27" extended clearance

DH-6000T-VHR

33.94"w x 31.63"d x 79"h



### Undercounter Dishwashers

- "Shear Energy" – a reduction in energy requirements while maximizing performance
- "Multi-Power" – includes "Multi-Volt" and "Multi-Phase" allowing for infield conversion to 208-240 volt and/or single to three phase with ease
- Wash Refresh™ – Fresh water rinse
- StemSure™ – Soft start to protect glasses and dishes from chipping and breaking
- Rinse Sentry – extends the cycle time to ensure 180°F/82°C final rinse
- Built-in electric booster for 180°F/82°C final rinse water (standard 40°F/22°C or optional 70°F/39°C rise)
- Detergent and rinse aid pumps
- Independent stainless steel interchangeable upper and lower wash and rinse arms
- Stainless steel top and side panels
- 90-second total cycle time
- Automatic drain cycle
- 1 hp motor
- Stainless steel construction
- 1 year parts and labor warranty

#### UH330B-Heat Recovery

- Cold water feed only with heat recovery
- Dry Assist dries wares faster

#### Without Booster

UH130B 141 Second Cycle, 25 Racks per hour, 1.8 gal/Rack

#### With Booster

UH230B\* 90 Second Cycle, 40 Racks per hour, 0.78 gal/Rack  
 UH330B\* Select 150/200/277 Second Cycles, 24/18/13 Racks Per Hour, 0.76 Gal/Rack, With Heat Recovery

\* ENERGY STAR®



UH130B





## Single Tank Conveyor Dishwasher

- High rack capacity—233 racks per hour
- Patented CrossFire® Wash System
- Easy glide door
- Front mounted tank = easy cleaning and maintenance
- Color-coded curtains
- Optional VRS ventless system
- SureFire® Start-Up and Check-Out Service
- 24/7 phone support

Admiral 44-4 43½" w x 31¼" d x 67¾" h

Energy efficient—0.63 gallon per rack final rinse consumption

## Quadjet Aqua-Scrubber™

- Automatic pot and pan washing system reduces labor costs up to 56%
- Specially designed patented nozzles scrub heavily soiled pots and pans
- 14 gauge type 304 stainless steel
- NEMA 4X control panel enclosure
- Heavy-duty pump with a 2 hp TEFC motor
- S/S utensil basket
- Seamless front skirt
- Fast flow mixing faucets
- Single point electrical connection: motor, controls, heater
- Basket style high capacity lever action waste drain
- Welded support legs with S/S feet
- Dual water temperature settings: 110°F low/130°F high
- 2.5 kW heater with low water protection and dual temperature control

Aqua-Scrubber Custom Build or Choose From Two Pre-Engineered Systems—The Dash 109 or The Marathon 140

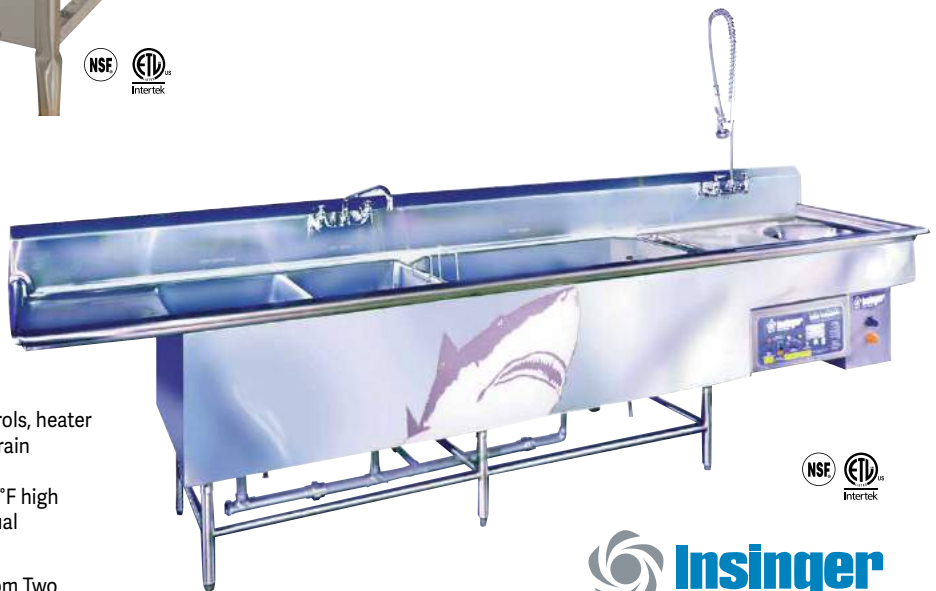

Basket style high capacity lever action waste drain



## Smart-Scrubber™

- The smart alternative to a standard 3 compartment sink
- 16 gauge stainless steel construction with rolled front edge and hemmed edge sides and 11" backsplash
- Automatic pot and pan washing system with six high velocity water jets to create a turbulent whirlpool action
- Simplified design
- SMART controls: pump on/off and heat on/off
- 1 hp pump motor and heat source that is not immersed in water
- Single point electrical connection
- Welded support legs with stainless steel feet
- 120V

Smart-Scrubber Available in 96", 112" or 136" Widths



### Automatic Triple Tank Tray Washer

- Tank heat: 16 kW electric immersion heater or steam injector
- Capillary thermometers for wash and rinse
- In-line thermometer for final rinse
- Vacuum breaker on all incoming water lines
- Manifold clean-out brush
- Vents with adjustable damper controls
- SureFire® Start-Up & Check-Out Service
- S/S frame, legs and feet
- S/S front enclosure panel
- Automatic tank fill
- Top mounted NEMA 12 control panel
- Wide insulated swing-out doors
- Standard frame TEFC motors
- Override switch for de-liming
- Tray unload table

TRAC 878 878 Trays/Hour



### Hi-Temp Door Type Dishwasher

- 65 racks per hour
- 17½ gal tank capacity
- Standard, extended and heavy soil wash cycles
- Quad-arm wash system
- Submerged booster recaptures radiant heat
- Heat-Save overflow reduces energy consumption
- 110° water inlet temperature
- Gas springs for smooth motion and safe removal
- Foot operated drain eliminates back strain
- Vertically mounted pump motor
- Hinged dishrack support swings up for tank and scrap screen access
- Dish rack guides nest and lock for storage

CX20 29" w x 38¾" d x 76⅞" h



### Hi-Temp Undercounter Dishwasher

- 30 racks per hour, 0.8 gal of water per rack
- Full stainless steel construction
- Revolving interchangeable stainless steel upper and lower wash/rinse arms
- Built-in detergent and rinse aid dispensers with EZ Prime system
- Built-in atmospheric booster with dedicated rinse pump provide consistent, constant 180°F hot water
- Three dedicated wash cycles
- Waterproof membrane control switches
- Automatic pumped drain with removable overflow tube
- Single step drain and clean system

CADET 23⅝" w x 20" d x 33½" h

# SUPPLIER SPOTLIGHT

## Hi-Lo Floor Scrub Brush

- Made with three different brush surfaces for cleaning at different angles
- The split shape is efficient for cleaning flat surfaces, under counters, around equipment and along baseboards
- Non absorbent foam block and synthetic bristles
- Color: White (02), Blue (14), Green (09), Red (05), Yellow (04)

40423 10" Brush, Specify Color



## Duo Pan™ Lobby Pan

- Pivoting bucket locks open for hands-free disposal
- Designed for use on both hard or soft floor surfaces

361410 12" Plastic Pan, 30" Metal Handle

## Duo-Sweep® Brooms

- Two handle holes: upright for general sweeping and angled for in corners, along walls and hard-to-reach areas
- Includes 30" long metal handle

36860 7½" Unflagged Straight Lobby Broom  
36865 12" Flagged Angle Broom



36860



36865



41881

41880



Angled pitch for fast, effective sweeping.

## Omni™ Floor Sweeps

- Combines the features of fine, medium, and heavy floor sweeps all in one convenient product
- Synthetic bristles have pitched angle for fast, effective sweeping on all types of floor surfaces
- Short, heavy bristles in front easily sweep up heavy debris
- Long, fine/medium bristles in back for sweeping fine dust and particles; can be used with sweeping compounds
- 40225 fiberglass handle available in Brown (01), White (02), Black (03), Yellow (04), Red (05), Green (09), Blue (14), Orange (24), Tan (25), Purple (68) to complement your HACCP program



41880 18" Hygienic Plastic Block  
41881 24" Hygienic Plastic Block  
40225 60" Threaded Handle w/Self Locking Tip



## Oven & Grill Brush

- Cleans hot grills quickly
- Will not scratch grills or lift cure
- 2 sided: extra stiff/semi-stiff stainless steel bristles

40290 30" long



## Sparta® Spectrum® Cutting Board Brushes

- Help reduce the risk of cross contamination and ensure proper sanitation with color codes to segregate brushes by task or work zone
- Colors: Blue (14)-Seafood, Green (09)-Produce, Red (05)-Raw Meat, Tan (25)-Cooked Meat, White (02)-Dairy, Yellow (04)-Poultry

41342 6" Cutting Board Brush, Assortment Pack\*  
40521 6" Cutting Board Brush, Specify Color  
\* Includes one of each color





## MaxiPlus® Lobby Dust Pan

- Rear wheels improve wear resistance
- Ultra thin edge makes sweeping up particles quick and easy
- Easy-Lock™ 33" handle securely locks handle in upright position; truly "hands free" emptying
- Swivel hang cap on handle allows product to be hung in any direction



96208 Lobby Dust Pan

## Cotton Cut-End Mops

- 1/4" narrow band

97613V #24  
97614V #32



## Quick Change™ Mopstick

- Durable yet lightweight 60" x 1" fiberglass handle
- Heavy-duty black plastic frame
- Easy trigger release
- Fits mopheads up to 32 oz

96516



## MaxiPlus® Professional Angle Brooms

- Fully washable, long-lasting synthetic PET bristles
- 48" metal handle with swivel hang cap
- 14" sweeping surface

91284 Red Unflagged Bristles  
91351 Tan Flagged Bristles



## Bi-Level Floor Scrub Brush w/Squeegee & Handle

- Scrubs baseboards and floors with one stroke
- Heavy-duty 10" plastic block will not crack, warp, or mildew
- Washable 2" red polypro bristles prevent spread of germs
- 54" black metal threaded handle

6615 10" Brush w/Squeegee Handle



## MaxiClean® Loop-End Mop

- High quality 4-ply cotton/synthetic blend yarn
- 5", 100% vinyl-coated mesh headband
- Tailband allows mop to spread evenly on the floor

97175 Small, White



## Floor Squeegee w/Handle

- 3" twin synthetic rubber blades
- Galvanized metal frame
- 54" handle included

6818 18" Squeegee w/Handle



## MaxiPlus® Mop Bucket w/Wringer

- Ergonomic wringer handle
- 3" non-marking swivel casters
- Green

6980 36 qt Bucket



# SUPPLIER SPOTLIGHT



## Bronco™ Round Waste Containers & Lids

- Heavy-duty construction with double-reinforced stress ribs and drag skids for ultimate durability
- Ergonomic Comfort Curve™ handles
- Reinforced stacking lids have tab locks to snap lids down tight
- NSF standard #2 (food contact and cleanability) and #21 listed
- BPA free
- Colors: White (02), Yellow (04), Red (05), Green (09), Blue (14), Gray (23) & Orange (24), Black (03)

Waste Containers	Lids	Fit
341010 10 Gallon	341011	10 Gallon
341020 20 Gallon	341021	20 Gallon
341032 32 Gallon	341033	32 Gallon
341044 44 Gallon	341045	44 Gallon
341055* 55 Gallon	341056	55 Gallon

\* Not available in Orange



## Cleaning & Sanitizing Buckets

- Green buckets for cleaning solutions
- Red buckets for sanitizing solutions

Green	Red	
BUCSG	BUCSR	3 qt
BUCMG	BUCMR	6 qt
BUCLG	BUCLR	8 qt

**CRESTWARE**



**CARLISLE**  
FOODSERVICE PRODUCTS

## TrimLine™ Waste Container, Lids & Dolly

- Heavy-duty plastic construction
- Fits neatly beside work tables or in narrow spaces
- Helper handle on the bottom makes lifting and dumping easier
- Corner tabs help keep trash bags secure
- Lids sold separately
- Colors: Beige (06), Black (03), Brown (69) and Gray (23), 342023 also available in Blue (14)

342023	23 Gallon Waste Container
342024	Swing Top Lid for Trimline Waste Containers
342025*	Handled Flat Lid for Trimline Waste Containers, Black
3692003*	Dolly for Trimline Waste Containers, Black

\* Available in Black only

## Round Container Dolly

- Dolly fits 20, 32, 44 and 55 gal containers for safe transport of heavy loads
- Simple twist-to-lock feature securely attaches dolly; containers can be pushed or lifted without accidentally coming off
- Standard Carlisle non-marking 3" swivel casters easily and cleanly roll over a variety of surfaces—indoors or out
- BPA free
- Black (03)

36911 17 1/4" x 6"

**CARLISLE**  
FOODSERVICE PRODUCTS



## Backwoods Series Table Tops

- Engineered wood panel construction with durable laminate top
- Laminate options have the look & feel of wood grain
- 1" Economy or 2" dropped edge Premium options
- Each top created is hand finished to order
- Laminate options include: Natural Sheesham, Smoked Oak, Natural Bamboo, Chili Powder, Gun Powder, Roble, Stormy Skies, Barn Wood Gray and Bengal Brown



## CTM Series Table Tops

- T-mold edge with 3" radius corners
- 1½" thick industrial grade particle board with high pressure laminate
- Formica and Wilson Art laminates standard, others available
- Rubber T-mold edge available in: White, Black, Brown, Wine, Hunter Green, HW Taupe and HW Smoke Gray



## Vinyl, Upholstered and Wood Booths

- Fully sculpted springless seat—no springs to break, sag or squeak
- Finished ends and back standard on vinyl/upholstered booths up to and including 72" long
- Wood booth outside back panel is unfinished—optional oak veneer finished back available for an upcharge
- One step black toe kick with poly corners, wood and metal leg option
- Countless styles available
- Pair with coordinating benches



## Woodland Series Table Tops

- 1" Red Oak faced table top with a 1½" solid wood dropped edge
- Clear coat or dark walnut stain options in stock
- Available with any in-house stain or color (subject to manufacturer lead times)
- Custom sizes & stains available



## Fortress Series Table Tops

- 1¼" industrial particle board core with ¾" dropped edge
- 11 gauge clear coated steel edge with exposed fasteners
- Available tops: Laminate, E\*wood, Charred Darkwash and Whitewash
- Standard and custom sizes available



DHC FURNITURE, INC.

## Solid Beech Chairs & Barstools

### Chairs

260 D-06 19¼" w x 22" d x 34¾" h, Natural Finish w/Black Cushion

260 D-17 19¼" w x 22" d x 34¾" h, Walnut Finish w/Sand Cushion

### Barstools

260B D-06 17" w x 20" d x 43½" h, Natural Finish w/Black Cushion



# SUPPLIER SPOTLIGHT



BM-234



CM-234



SC135C



SC135C-1

## Standard Ladderback Metal Chair & Barstool

- 1 1/4" steel tubing welded frame
- Premium black powder coat wrinkle finish
- Non-marring glides
- Vinyl seat options: Black (BLK), Buckskin (BUC), Espresso (ESP), Red (RED) and Wine (WINE)
- Wood seat options: Black (WB), Cherry (C), Mahogany (M), Natural (N), Walnut (WA) and Reclaimed Wood (RW) - add suffix to item number to specify

CM-234 Chair, 15 7/8" w x 15 3/16" d x 32 1/4" h  
 BM-234 Barstool, 15 7/8" w x 15 3/16" d x 42 1/4" h

## Clear Coat Ladderback Metal Chair & Barstool

- 1 1/4" steel tubing welded frame with plain or brass welds
- Non-marring glides
- Wooden seat finishes: Black (WB), Cherry (C), Mahogany (M), Natural (N), Walnut (WA) and Reclaimed Wood (RW)
- Vinyl seat options: Black (BLK), Buckskin (BUC), Red (RED), Wine (WINE) or Espresso (ESP) - add suffix to item number to specify
- Custom vinyl and upholstery also available

SL135C Chair, 15 3/4" w x 16" d x 32 1/2" h  
 SL135C-1 Barstool, 15 7/8" w x 15 3/4" d x 42 3/8" h



CM-234R



BM-234R

## Rustic Ladderback Metal Chair & Barstool

- 1 1/4" steel tubing welded frame
- Premium clear coat finish
- Non-marring glides
- Vinyl seat options: Black (BLK), Buckskin (BUC), Espresso (ESP), Red (RED) and Wine (WINE)
- Wood seat options: Black (WB), Cherry (C), Mahogany (M), Natural (N), Walnut (WA) and Reclaimed (RW) - add suffix to item number to specify
- Custom vinyl and upholstery also available

CM-234R Chair, 15 7/8" w x 15 3/4" d x 32 3/8" h  
 BM-234R Barstool, 15 7/8" w x 15 1/16" d x 42 3/8" h



SL2160



SL2301

## Premium Ladderback Metal Chair & Barstool

- Heavy gauge 1 1/4" steel tubing welded frame
- Premium black powder coat wrinkle finish
- Wood seat finish: Black (WB), Cherry (C), Mahogany (M), Natural (N), Walnut (WA) and Reclaimed Wood (RW)
- Vinyl seat options: Black (BLK), Espresso (ESP), Red (RED), Wine (WINE) and Buckskin (BUC) - add suffix to item number to specify

SL2160 Chair, 15 3/4" w x 15 3/4" d x 33 3/4" h  
 SL2301 Barstool, 15 7/8" w x 15 3/16" d x 44" h  
 SL2301-S Swivel Barstool, 16 1/8" w x 17" d x 46 1/4" h

## Budget Ladderback Metal Chair & Barstool

- 1 1/4" steel tubing welded frame
- Premium black powder coat wrinkle finish
- Non-marring glides
- Black vinyl seat
- 15 7/8" w x 15 3/16" d



CM-1160



BM-1301

CM-1160 Chair, 32 1/4" h  
 BM-1301 Barstool, 42 1/4" h

1430 WG-GRY



1431 WG-GLD



### Dining Chairs

- Powder coated steel frame
- Fully wood seat and back
- 17" w x 19" d x 32" h

1430 WG-GRY Black Frame, Grey Oak Laminated Back & Seat  
 1431 WG-GLD Silver Frame, Golden Oak Laminated Back & Seat

### Industrial Steel Chair

- Constructed of high quality 18 gauge steel tubing
- Antique Gray Finish
- Features an all steel frame with vinyl seat
- Fully welded

1589 GRY 17" w x 19" d x 33" h



### Dining Chairs

- Constructed of select solid European Beech Wood
- Black vinyl seat



245 D-19



279D-01

#### Ladder Back

245 D-19 17" w x 21 1/2" d x 34 1/2" h, Antique Walnut Finish, Black Vinyl

#### Upholstered Back

279 D-01 19" w x 20" d x 34" h, Mahogany Finish, Black Vinyl



### Steel Bar Stool

- All welded steel frame
- Silver powder coating finish
- Black vinyl seat
- Two hand bag hooks

3306 15 1/2" w x 14" d x 29 1/2" h



### Steel Dining Chairs

- Constructed of high quality 18 gauge steel tubing
- Fully welded



1459 BLK



1444 CLR

1459 BLK 17" w x 19" d x 32" h, Powder Coated Finish  
 1444 CLR 17" w x 19" d x 31 1/2" h, Clear Finish

### Rattan Patio Chairs

- Constructed of high quality aluminum tubing
- Stackable
- Fully welded



7075



7055-BR

7075 17" w x 19" d x 33" h, Outdoor Powder Coating, Black + White Rattan  
 7055 17" w x 19" d x 33" h, Outdoor Powder Coating, Brown + Natural Rattan

### Aluminum Patio Chairs

- High quality outdoor powder coating
- Stackable
- Colors: Brown (BRW) and Red (RED)



BROWN



RED

7907 17" w x 19" d x 33" h

# SUPPLIER SPOTLIGHT

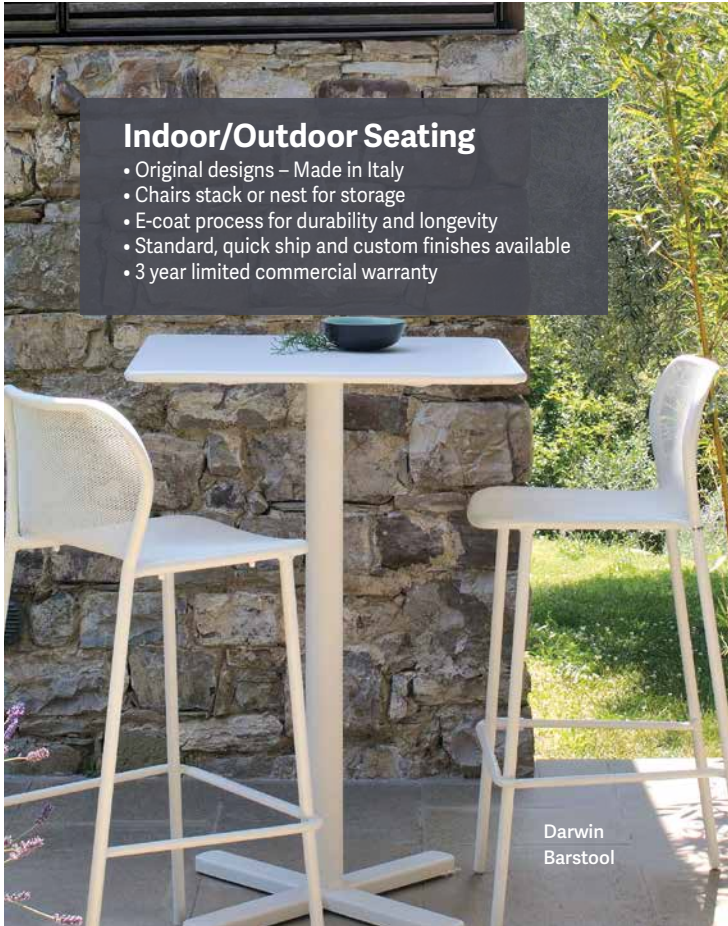

## Indoor/Outdoor Seating

- Original designs – Made in Italy
- Chairs stack or nest for storage
- E-coat process for durability and longevity
- Standard, quick ship and custom finishes available
- 3 year limited commercial warranty

Darwin  
Barstool

Other color options available, please ask your sales representative.

## Thor



657  
Thor Barstool



655  
Thor Side Chair



## Ronda



119  
Ronda Barstool



116HD  
Ronda Armchair



111  
Ronda Side Chair

## Darwin



523  
Darwin Barstool



522  
Darwin Armchair



521  
Darwin Side Chair



524  
Darwin Lounge Chair



526  
Darwin Low Table



## Mom Stacking Chairs

- Perfect for indoor or outdoor use
- Solid steel cut-out style back and seat
- Tubular steel frame
- E-coated powder coat finish

- 639 Side Chair, 21"w x 22"d x 30"h
- 640 Arm Chair, 23"w x 22"d x 30"h
- 649 Barstool, 22½"w x 22"d x 40"h





Umbrella Base  
Sold Separately

### EMU Shade

- One piece 1½" dia anodized aluminum pole
- Includes single vent canopy made of commercial grade fabric
- Fits on standard size umbrella bases
- Simple open/close system, self locking
- Available in Circus Red (5877), Black (5808) or Khaki (5822)

- 980 6½' Square w/Pole, 78½" w x 95" h
- 986 8½' Hexagon w/Pole, 98½" w x 94" h



### Outdoor Bistro Tables

- Solid top, solid steel base with tubular steel column
- E-coating process guarantees quality, durability and longevity
- 3 year structural, surface and finish limited warranty for outdoor commercial use
- Quick ship finishes available: Aluminum, Antique Iron, Antique Bronze, and Antique Black

- |     |                |                     |
|-----|----------------|---------------------|
| 900 | Round, 24" dia | <b>Bar Height</b>   |
| 901 | Square, 30" sq | 900H Round, 24" dia |
| 902 | Round, 32" dia | 902H Round, 32" dia |



SUPPLIER SPOTLIGHT



### Cambi Mesh-Top Outdoor Metal Tables

- Steel mesh top with tubular steel legs
- | With Umbrella Hole |                | Without Umbrella Hole |                           |
|--------------------|----------------|-----------------------|---------------------------|
| 813                | Round, 36" dia | 800                   | Square, 24" sq            |
| 803                | Round, 32" dia | 834                   | Rectangular, 24" x 32"    |
| 804                | Round, 42" dia | 820                   | Round Bar Height, 32" dia |
| 805                | Round, 48" dia |                       |                           |
| 801                | Square, 32" sq |                       |                           |
| 802                | Square, 36" sq |                       |                           |

# SUPPLIER SPOTLIGHT



## The Chemistry Collection

- Make some great concoctions with these new chemistry flasks and beakers
- Mixologists will have a blast with this collection that features capacities right on the glass

Flasks	Capacity	Dia x H
GF2	1 1/4 oz	2" x 3 3/4"
GF3	5 oz	3" x 4 3/4"
GF8	8 1/2 oz	3 1/2" x 5 3/4"
GF17	17 oz	4" x 7"
GF34	34 oz	5" x 8 3/4"
GF68	68 oz	6 1/2" x 11"

Beakers	Capacity	Dia x H
GBE2	1 1/4 oz	1 3/4" x 2 1/4"
GBE3	3 1/2 oz	2 1/2" x 3"
GBE8	8 1/2 oz	3" x 4"
GBE17	17 oz	3 3/4" x 5"
GBE34	34 oz	4 1/4" x 5 1/4"
GBE64	64 oz	5 1/4" x 7 1/2"



SMC18

Cool ice is really hot right now! Accent your cocktails with these trendy new ice molds!

## Ice Molds

- Made of dishwasher-safe, BPA-free, food-safe silicone
- Withstand temperatures from -4° to 392°F

SMSC4	Large Cube Mold w/Lid, (4) 2" Cubes, 4 1/2" w x 4 1/2" l x 2" h
SMSC8	Medium Cube Mold, (8) 2" Cubes, 4 1/2" w x 8 1/2" l x 2" h
SMSR8	Sphere Mold, (6) 1 1/2" dia Spheres, 4 5/8" w x 7" l x 1 1/2" h
SMSR4	Sphere Mold, (4) 2 1/2" dia Spheres, 6 1/8" w x 6 1/8" l x 2 1/2" h
SMC18	Small Cube Mold, (18) 1 1/4" Cubes, 10 3/4" w x 5 1/2" l x 1 1/2" h



SMSR8

SMSR4



SMSC4

SMSC8





HBB909

HBB908



### Bar Blenders

- Perfect for a variety of uses including salsas, dips, soups, cocktails, fruit smoothies and more
- 2-speed with pulse option
- Comes with stainless steel mixing blades and Sure Grip™ feet
- ½ hp motor, 120V
- 1 year parts and labor warranty

HBB909 With 32 oz Stainless Steel Container  
 HBB908 With 44 oz Poly Container

### Quantum™ 950 Blender



- Next generation brushless motor technology
- Endura™ motor technology is engineered to last 2.5 times longer
- Advanced Quiet Shield™ enclosure
- Wave-Action® system
- Over 30 pre-programmed cycles
- Touchpad controls
- USB port
- Stackable polycarbonate container
- 7 year parts and labor on motor, lifetime warranty on motor drive and blades
- 3 year parts and labor on all other parts, 2 year ExpressCare Replacement Warranty



Ready to learn more about these great products?  
**PLAY VIDEO**



HBH950 64 oz



### Glass Rimmer

- Provides a consistent and even coat of salt every time



GR10 Two Tier

### Precision Pour™ 3 Ball Liquor Pours

- Eliminates over pouring and spillage
- Speeds up drink production by allowing bartenders to pour liquor with one hand and mix with the other
- Eliminates need for shot glasses and jiggers
- Available in a number of configurations including a flip-top seal and a heavy cork for oversized bottle openings
- Available Colors: Amber, Blue, Clear, Green, Red, Purple and Chrome
- Shot sizes: ¼, ½, ⅔, ¾, 1, 1½, 1¾, 2 and 3 oz
- Made in the USA



- 100WR 3 Ball Pour, 1 oz, Watermelon Red
- 100WRF 3 Ball Pour w/Flip, 1 oz, Watermelon Red
- 100BLC 3 Ball Pour w/Collar, 16 oz, Blue
- 100BLCF 3 Ball Pour w/Collar & Flip, 16 oz, Blue
- 100CH 3 Ball Pour, 1 oz, Chrome
- 100CHC 3 Ball Pour w/Collar, 1 oz, Chrome



100CH

100CHC

SUPPLIER SPOTLIGHT

# SUPPLIER SPOTLIGHT

## Eclipse™ High Performance Blenders

- QuietBlend™ technology
- Advanced Quiet Shield™ enclosure
- Quiet Shield™ sensor turns off motor when operator lifts the shield
- Wave-Action® system
- Powerful 3 peak hp motor
- 100 pre-programmed cycles
- Stackable polycarbonate container
- Touchpad controls
- Unit can be converted to in-counter use
- 3 year parts and labor warranty, 2 year ExpressCare Replacement warranty and Lifetime warranty on motor drive and blades

HBH750 48 oz Container  
 HBH755 64 oz Container



Ready to learn more about these great products?

**PLAY VIDEO**



## RIO™ Bar Blenders

- Wave-Action® system continually forces mixture down into the blades
- 2 speed with pulse option
- Comes with Sure Grip™ feet, and blade assembly unit with stainless steel blades
- Perfect for bars serving 15-24 frozen drinks per day
- Blends a 16 oz daiquiri in just 20 seconds
- ¾ peak hp motor, 120V
- 2 year parts and labor warranty



HBB250R



HBB250R 44 oz Stackable Polycarbonate Container  
 HBB250SR 44 oz Stainless Steel Container

## TANGO™ Bar Blender

- Wave-Action® system continually forces mixture down into the blades
- Blends a 16 oz daiquiri in just 15 seconds
- 2 speed with pulse option
- Timer with automatic shutoff
- Comes with 4 durable stainless steel blades and Sure Grip™ feet
- Durable all metal clutch and motor drive
- 1 hp motor, 120V
- 2 years parts and labor warranty covered under Express Care Replacement Warranty program



HBH450R 48 oz Stackable Polycarbonate Container

## Fury™ High-Performance Blender

- 2 speeds, high/low/pulse with auto shut off timer
- Wave-Action® system continually forces mixture down into the blade for a creamy smooth drink profile
- All-metal drive coupling is built to last
- Timer automatically turns blender off after a preset time
- Stackable container
- 3 hp motor
- 3 year parts and labor warranty, 2 year Expresscare Replacement warranty and Lifetime warranty on motor drive and blades



Ready to learn more about these great products?  
**PLAY VIDEO**



HBH550 64 oz Stackable Polycarbonate Container



## Tempest High-Performance Blender

- 2 speeds, jump cycle, pulse and timer
- Wave-Action® system continually forces mixture down into the blade for a creamy smooth drink profile
- Timer with automatic shutoff
- Jar pad sensor turns off motor when container is not in place to prevent careless clutch grinding
- 120V, 3 hp
- 3 year parts & labor warranty, 2 year Expresscare Replacement warranty and Lifetime warranty on motor drive and blades



HBH650 64 oz Stackable Polycarbonate Container

## Serving Spoons

- One piece polycarbonate construction
- Dishwasher safe
- Recommended for temp. up to 212°F, withstands dry heat up to 270°F
- Notched handle rests on edge of food pan
- Slot at end for hanging

- Colors: All available in Black (03) and Clear (07), \*Exceptions: 4421 and 4431 only available in Black (03); Some available in Beige (06), Forest Green (08), Red (05) or White (02)

Solid	Perforated	
4410	4411	11" long
4420	4421*	13" long
4430	4431*	15" long



## Clear Tongs

- Break resistant polycarbonate
- For temperatures up to 212°F
- Dishwasher safe

4006	Salad Tongs, 6" long
4009	Salad Tongs, 9" long
4109	Utility Tongs, 9" long
4112	Utility Tongs, 12" long



## Classic™ Crocks

- Thick walled heavyweight design made of high quality SAN
- Excellent chemical resistance to food acids, dressings
- High gloss finish is scuff resistant
- 0° to 180°F temp. range

- Dishwasher safe
- Translucent snap on lids included
- Colors: Beige (06), Black (03), Clear (07), Brown (01) or White (02) \*0316 not available in White (02)

0301	1.2 quart
0316*	1.5 quart
0302	2.7 quart



## Poly-Tuf™ Crocks

- Resilient polypropylene
- Resists chipping and cracking
- 32° to 180°F temp. range
- Dishwasher safe
- Translucent snap on lids included
- Colors: Beige (06), Black (03) and Brown (01)

0341	1.2 quart
0343	1.5 quart
0342	2.7 quart



# SUPPLIER SPOTLIGHT

## Coldmaster® Ice Cream Server

- 12¼" dia, holds 3 gallon ice cream tubs
- Non-toxic refrigerant gel holds temperature longer than any other similar product
- Made of durable, high-impact ABS plastic
- Dishwasher safe
- Clear polycarbonate lid protects against contaminants; helps maintain cold temperature

CM1012 3 Gallon



## Coldmaster® Insulated Food Pans

- Fits standard sized food pan templates
- Will hold food temperatures at or below the ServSafe® 40°F for eight hours (based on pre-frozen for at least 8 hours, then filled directly with pre-chilled foods - ambient room temp. of 76°F)
- Eliminates the inconvenience and mess of ice
- Pans are 6" deep
- Colors: Black or White

CM1100 Full Size Pan  
 CM1101 Half Size Pan  
 CM1102 Third Size Pan  
 CM1103 Third Size Divided Pan  
 CM1104 Sixth Size Pan



## Coldmaster® CoolCheck™ Insulated Food Pans

- Same great features as Carlisle's standard Coldmaster products with the added element of color-changing technology
- Container holds food safely below 40°F for 6-8 hours
- Simply charge in the freezer overnight
- Eliminates the mess and inconvenience of ice
- Blue color indicates food safe temperatures below 41°F
- White color lets workers know when food temperatures are no longer safe
- FDA approved; dishwasher safe
- 6" deep



CM1100C1402 Full Size  
 CM1101C1402 Half Size  
 CM1102C1402 Third Size  
 CM1103C1402 Third Size Divided  
 CM1104C1402 Sixth Size  
 CM1105C1402 Sixth Size High Capacity



## Designer Coldmaster® Displayware

- Simply charge overnight to hold food temperatures at or below the ServSafe® 40°F for up to four hours
- Eliminates messy ice baths
- Made of high impact ABS material
- Clear polycarbonate lids are available to help preserve food freshness, especially when serving outdoors
- Dishwasher safe
- Available in your choice of White (02), Black (03), White/Pewter (440) or Black/Charcoal (441)

**Bowls**  
 CM1400 1 qt Flared Square  
 CM1401 2 qt Flared Square  
 CM1402 5 qt Flared Oval  
 CM1403 Solid Lid, 1 qt Container  
 CM1404 Notched Lid, 1 qt Container  
 CM1405 Solid Lid, 2 qt Container  
 CM1406 Notched Lid, 2 qt Container  
 CM1407 Solid Lid, 5 qt Container  
 CM1408 Notched Lid, 5 qt Container





### Cateraide™ Insulated Top Loaders

- Accommodates all third, half and full size pans
- Exclusive auto venting system eliminates unsanitary vent openings
- Nylex™ latches eliminate sharp edges; won't rust, bend or dent
- Colors: Black (03), Brown (01)

PC140N 12 qt, 4"d  
 PC160N 18 qt, 6"d



### Cateraide™ IT Beverage Dispenser

- Durable construction and reinforced corners
- Button-hole latch design offers convenient, one-hand operation
- Latches are field adjustable
- Integrated writing surface
- Featuring "spring action" faucet for no drip service
- Extra wide, sure-grip handles
- Colors: Black (03) and Tan (25)



IT500 5 Gallon



SUPPLIER SPOTLIGHT

### Cateraide™ Insulated End Loader

- Nylex™ latches eliminate sharp edges; won't rust, bend or dent
- Each food pan fits on its own track, no need to remove all pans to get to the one you want
- Colors: Brown (01), Black (03), Forest Green (08) and Slate (59)

PC300N Holds (5) 2½"d Pans



### Cateraide™ Beverage Dispensers

- Thick foam insulation retains temperatures
- Spring action faucet for dripless service
- Easy-grip, formed handles
- LD250N colors: Brown (01) and Black (03); LD500N available in Brown (01), Black (03), Forest Green (08) and Slate (59)

LD250N 2½ Gallon  
 LD500N 5 Gallon



# SUPPLIER SPOTLIGHT

## Cateraide™ IT Pan Carriers and Dolly



- Commercial foam insulation for superior food quality and safety
- Button-hole latch design offers convenient one hand operation and keeps the doors and lids closed tightly for better temperature retention
- Latches are field adjustable to ensure a secure seal for the life of the carrier
- Flat top that can be used as a prep surface when space is limited

- Built-in seal to eliminate gaskets
- Extra wide, sure-grip handles to promote a safe, stable two-person lift for easy loading, unloading
- End loader's exclusive double hinge opens 270° for easy loading and unloading and lies flat to save space
- Colors: Onyx (03) and Caramel (43), IT400 also available in Olive (62)

IT160 Top Loader, 6"d  
 IT400 End Loader, 6 Pan Capacity  
 IT41003 Dolly for IT400, Onyx



## Mirage® Cadet Countertop Induction Range

- Stainless case top
- G1 engine
- 20 power levels
- 100° to 450°F range
- Push button control with digital readout
- 14" max pan size
- 120V, 1.8kW



59300 12"w x 16"d x 3 3/8"h



## Mirage® Pro Countertop Induction Range

- Stainless case top
- G4 engine
- 100 power levels for precise cooking control
- 80° to 400°F range, featuring a lower range for chocolates
- Knob control with digital readout makes settings quick and clear
- Digital display
- Low-profile, modern case design
- 14" max pan size
- 120V, 1.8kW

59500P 14"w x 15 1/4"d x 3"h

← LED indicator lights on control panel and glass

## Mirage® Buffet Induction Warmers

- Connect up to 3 units together with included interconnect cords
- Subtle, low-profile, attractive design coordinates with any serving set-up
- Tempered black ceramic glass top
- Touch controls, 4 power settings
- 16 1/2" x 16 1/2" x 3 1/2"

59502DW Drop-In  
 5950280 Countertop, Natural  
 5950275 Countertop, Black





Nothing less than the best.®



### Rapid Cuisine® Countertop Induction Ranges

- Magnetic Power System delivers the highest power in its class
- Highest resolution TFT color display
- Large control knobs
- USB port for downloading updates
- IRNG-PC1-36 features a patterned, glass ceramic top that hides scratches

IRNG-PC1-18	13"w x 17"d x 3¾"h, 120V/1800W
IRNG-HC1-18	13"w x 17"d x 3¾"h, 120V/1800W
IRNG-PC1-36	13¾"w x 18½"d x 3¾"h, 240V/3600W



SUPPLIER SPOTLIGHT



Nothing less than the best.®



### Palletti™ Countertop Induction Warmers

- Elegant, contemporary, low-profile design with a bold black housing and durable, black glass-ceramic top that is easy to clean
- Pan Sense Technology (PST) activates the unit only when a suitable pan is placed on top
- Features a control panel with a standby key, temperature control arrow keys and temperature setting indicators
- Automatic shut-off to prevent overheating
- Low wattage warmers
- IWRM-CD1-03 can be interconnected with multiple units
- 13"w x 17¾"d x 2¼"h

IWRM-CD1-03	120V/360W
IWRM-C1-1317-06	120V/600W



# SUPPLIER SPOTLIGHT

## Pyramid Mobile Buffet

- Can be used as a rolling buffet or as tabletop risers
- Includes 5 pyramid shaped interlocking cubbies
- 10" slot on each side to insert shelving (shelves sold separately)
- Cubbies nest for storage
- Bamboo finished wood with stainless steel edging protectors
- 4 locking caster wheels on base cubby only



1805 17½"w x 76"h OA

**EASTERN**  
SINCE 1950



## Square Tabletop Display

- Heavy-duty brushed stainless steel
- One-piece construction
- Double-sided accessibility
- Shelves firmly set into stainless steel frame
- 8 glass shelves

ST1765 39½"w x 10"d x 31½"h

Stainless steel with polished finish

## Heat Lamp Warmers

- Self standing
- 120V
- 250W bulb(s)



9681

### Round-4 Star

9681 Single Lamp Warmer, Flexible Head, 33"h

9682 Double Lamp Warmer, Flexible Head, 33"h

### Square-4 Star

9611 Single Lamp Warmer, Full Swivel Neck, 33½"h

9612 Double Lamp Warmer, Full Swivel Neck, 33½"h

### Heavy Square-5 Star

9601 Single Lamp Warmer, Adjustable Locking Heights, Full Swivel, 22"h

9602 Double Lamp Warmer, Adjustable Locking Heights, Full Swivel, 23"h

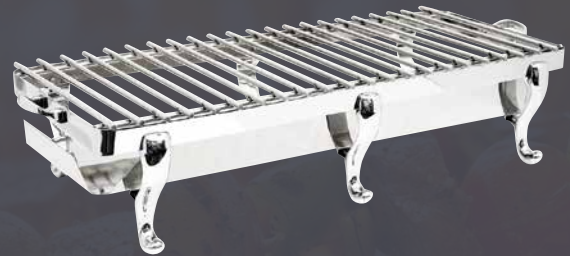

## Park Avenue Grill Stand

- Stainless steel with removable grill top
- Fits 2 butane burners or several fuel cans
- 41½"w x 11½"d x 10"h

3258G 41½"w x 11½"d x 10"h

## Mobile Buffet Cartwheel Displays

- Includes two half circle displays
- Heavy-duty 304/1810 stainless steel, one-piece construction
- Includes glass shelves, option of acrylic shelves
- 4 locking 5" casters
- Brushed finish helps minimize fingerprints
- Available in black, or coated in any custom color

ST1790 72½"w x 13¾"d x 72"h

Ready to learn more about these great products?

**PLAY VIDEO**



**EASTERN**  
SINCE 1950





### Coffee Urns

- One-hand dispensing
- Fast brewing - 1 cup per minute
- Tall base fits large 12 oz cups
- Coffee level indicator
- Dual heaters for brewing and gentle warming
- Boil dry protection
- Ready-to-serve light
- Brushed aluminum finish
- Locking lid
- Cool-touch handles
- 120V
- 1 year warranty

45040R 40 Cup

45060R 60 Cup

45100R 100 Cup



### Super Automatic Espresso Machines

- Capable of producing 14 different drinks
- Automatically cleans and rinses components every 15 minutes and after every drink
- Vacuum valve prevents milk from entering the boiler
- Intelliprogram™ smart features include programmable dosing, pre-infusion capabilities and management reporting
- Programmable on/off feature ensures machine powers up/down on time everyday
- Quiet internal motor with rotary-vane Procon pump
- Easy plumbed water connection & drain hook-up
- 22"w x 23"d x 38"h

SM111

Single Hopper

SM222

Double Hopper

Fully integrated refrigerator



**ASTRA**  
ARTFULLY ENGINEERED  
Espresso Machines & Steamers  
Stocked and Handcrafted  
in the USA

### Automatic Pourover Steamer

- Create an endless menu of specialty drinks including hot chocolate, juice, tea and smoothies
- Vacuum valve prevents milk from entering the boiler
- Vibration pump and low water safety system with alarm
- Lightweight, no plumbing required

STA1300

11"w x 18"d x 15"h



### Mega II Automatic Espresso Machine

- Deluxe two station espresso machine with a production capacity of 480 cups per hour
- Equipped with three steam wands and one hot water valve or two steam wands and two hot water valves
- 4500 watt heating element in 12 liter boiler
- Available in Silvertone, Coppertone, Black, Red and Blue
- 220V

M2012

27¼"w x 19½"d x 20"h

**ASTRA**  
ARTFULLY ENGINEERED  
Espresso Machines & Steamers  
Stocked and Handcrafted  
in the USA



# SUPPLIER SPOTLIGHT



## VersaPour™ Pitcher

- Made of break-resistant polycarbonate
- Ergonomic handle provides a sure comfortable grip
- Ice trap retains ice or beer foam
- Specially contoured lip design allows for easy pouring
- Dishwasher safe
- Colors: Amber (13), Clear (07)

5540 60 oz



5583

## Crystalite™ Pitchers

- Made of break-resistant polycarbonate
- Secure thumb hold on handle for better control when pouring
- Dishwasher safe
- Clear (07)

5583 48 oz  
5587 60 oz



5536

## Polycarbonate Pitchers

- Made of break-resistant polycarbonate for ultimate durability
- Ice trap retains ice or beer foam
- Dishwasher safe
- Clear (07)

5536 32 oz  
5538 48 oz



## Fry Cups

- Serve more than fries!
- Stainless steel in brushed and hammered finishes

**Straight Cups - 3 3/8" dia x 3 3/8" h**  
FFC337 Satin Finish  
FFHM37 Hammered Finish  
**Angled Cups - 2 7/8" dia x 4 1/2" h**  
FFCS45 Satin Finish  
FFHM45 Hammered Finish



## Mini Fry Baskets

- Just like their kitchen counterparts but a fraction of the size
- Stainless steel

FRYT433 Rectangular, 4 1/8" l x 3 3/8" w x 3" h  
FRYR375 Round, 3 1/2" dia x 2 3/4" h  
FRYS443 Square, 4" sq x 3" h

## Taco Holders

- Brushed stainless steel
- Great for presentation
- Invert each one to add another serving slot option

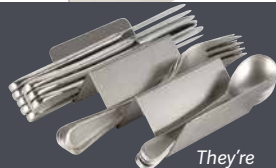

*They're versatile!*

### Taco Holders

TSH1 1 or 2 Compartments  
TSH3 2 or 3 Compartments  
TSH5 4 or 5 Compartments

### Mini Taco Holders

MTSH1 1 or 2 Compartments  
MTSH3 2 or 3 Compartments  
MTSH5 4 or 5 Compartments



## GripLite® Round Trays

- High density polypropylene co-polymer
- Molded-in rubber liner
- Prevents slipping and sliding of glasses and dinnerware
- More sanitary alternative to cork trays
- Stain and odor resistant; hand washing recommended
- Available in Black (004) and Tan (076)



1100GL 11" dia  
1400GL 14" dia  
1600GL 16" dia

## Griptite™ 2 Trays

- Patent-pending, non-skid surface prevents slipping and sliding of glassware and dinnerware
- Rubber liner is permanently bonded to the tray and covers side wall and tray top to provide extra grip
- Heavy-duty reinforced construction eliminates warping
- Stain and odor resistant, dishwasher safe
- Available in Black (004) and Brown (076)

Round		Oval	
1100GR2	11¾" dia	2500GR2	19¼" x 24"
1400GR2	14¾" dia	2700GR2	22⅝" x 27"
1600GR2	16" dia	3100GR2	23½" x 31½"



## Cafe® Fast Food Trays

- Economical polypropylene trays in an attractive Basket Weave pattern finish
- Drying and stacking lugs, skid resistant surface
- Custom hot stamping available
- Handled tray offers convenience, added strength

CT1014 10" x 14", Black (03), Red (05), Beige (06), Forest Green (08), Green (09), Blue (14), Teal (15), Gray (23), Orange (24), Slate Blue (59), Burgundy (61), and Chocolate (69)

CT1216 12" x 16", Black (03), Red (05), Beige (06), Forest Green (08), Green (09), Blue (14), Teal (15), Gray (23), Orange (24), Light Brown (31), Slate Blue (59), Burgundy (61) and Chocolate (69)

CT1418 14" x 18", Black (03), Red (05), Beige (06), Forest Green (08), Green (09), Blue (14), Teal (15), Gray (23), Orange (24), Light Brown (31), Mauve (56), Slate Blue (59), Burgundy (61) and Chocolate (69)



## Ramekins

- Choose thick walled, heavy weight melamine or economical SAN
- Serves sauces, butter, salad dressings, salsa, etc.
- Dishwasher safe

## Molcajete Ramekins and Salsa Dish

- Thick walled heavy weight melamine
- Dishwasher safe
- BPA free
- Colors: Black (03), 0875 also available in White (02), Bone (42) and Cobalt (60)

## SAN Ramekins

- Colors: 43121 available in Bone (42) only, 43122 available in Black (03) only, 43123 and 43126 available in Bone (42) and Black (03), 43126 also available in Cobalt Blue (60)



0873 Molcajete, 3 oz  
0878 Molcajete, 8 oz  
0875 Salsa Dish, 5 oz



43121	1½ oz	43123	3 oz
43122	2 oz	43126	6 oz



## Melamine Ramekins

A variety of colors available, ask your salesperson

S277	1¼ oz	S280	3 oz
S275	1½ oz	S285	4 oz
0852	2 oz		

# SUPPLIER SPOTLIGHT

## Gathering Dinnerware

- Durable, heavy-weight melamine
- Textured surface maintains good looks longer and enhances the appearance of plated foods
- Safe for temperatures up to 212°F
- 2 year warranty against chips and breakage
- Dishwasher safe and stain resistant
- Color: Adobe (70)

		PK
GA55002	Salad Plate, 9"	1 dz
GA55001	Dinner Plate, 11"	1 dz
GA55013	Charger Plate, 12½"	1 dz
GA55014	Oval Platter, 12"	1 dz
GA55012	Dip Bowl, 4¾", 10 oz	1 dz
GA55011	Small Bowl, 6¼", 10 oz	1 dz
GA55003	Small Bowl, 8", 35½ oz	1 dz



## Mingle Dinnerware

- Durable, heavy-weight melamine
- Textured surface maintains good looks longer and enhances the appearance of plated foods
- Swirl decoration draws the diner's attention to center of plate
- Safe for temperatures up to 212°F
- 2 year warranty against chips and breakage
- Dishwasher safe and stain resistant
- Colors: Straw (13), Aqua (15), Copper (17), Smoke (18), Ivy (46), Fireball (52)

		PK
54002	Salad Plate, 9"	1 dz
54001	Dinner Plate, 11"	1 dz
54018	Fruit Bowl, 5", 4½ oz	4 dz
54019	Cereal Bowl, 8", 35½ oz	1 dz
54013	Large Serving Bowl, 4.8 qt, 12"	6 ea
54003	Rimmed Soup Bowl, 9", 28½ oz	6 ea
54004	Ice Cream Bowl, 7", 27 oz	1 dz

## Grove Dinnerware

- Gently striped design makes standardized plating a breeze
- Durable, heavy-weight melamine
- Textured surface maintains good looks longer and enhances the appearance of plated foods
- Safe for temperatures up to 212°F
- Dishwasher safe and stain resistant
- 2 year warranty against chips and breakage
- Colors: Adobe (06), Aqua (15), Smoke (18), Jade (46), Buff (70)

		PK
64023	Dinner Plate, 8½"	1 dz
64002	Salad Plate, 9"	1 dz
64022	Square Dinner Plate, 10½"	1 dz
64001	Dinner Plate, 11"	1 dz
64020	Oval Plate, 12" x 8"	4 dz
64018	Fruit Bowl, 4¾", 5 oz	4 dz
64003	Soup Bowl, 9", 28½ oz	6 ea
64013	Ice Cream Bowl, 7", 27 oz	1 dz



## Dallas Ware® Melamine Dinnerware

- Offers superior stain and scratch resistance
- Reduce breakage and replacements with the Dallas Ware reinforced rim and foot design
- Reduce your china place setting cost by substituting side dishes
- Dishwasher safe
- Ask about available colors



NSF

Safe for temperatures up to 212°F

PK		PK	
43505	Bread & Butter Plate, 5 <sup>39</sup> / <sub>47</sub> "	43540	Bouillon Cup, 3 <sup>3</sup> / <sub>4</sub> ", 8 oz
43504	Pie Plate, 6 <sup>1</sup> / <sub>2</sub> "	43532	Fruit Bowl, 4 <sup>1</sup> / <sub>8</sub> ", 3 <sup>1</sup> / <sub>2</sub> oz
43503	Salad Plate, 7 <sup>1</sup> / <sub>4</sub> "	43533	Oval Fruit Dish, 6 <sup>1</sup> / <sub>2</sub> oz
43501	Dinner Plate, 9"	43529	Grapefruit Bowl, 5 <sup>7</sup> / <sub>8</sub> ", 10 oz
43500	Dinner Plate, 10 <sup>1</sup> / <sub>4</sub> "	43528	Nappie Bowl, 5", 10 oz
43531	Fruit Bowl, 4 <sup>1</sup> / <sub>2</sub> ", 4 <sup>3</sup> / <sub>4</sub> oz	43525	Nappie Bowl, 5 <sup>1</sup> / <sub>4</sub> ", 13 oz
43522	Rim Nappie Bowl, 5 <sup>5</sup> / <sub>17</sub> ", 14 oz	43521	Nappie Bowl, 5 <sup>1</sup> / <sub>2</sub> ", 14 oz
43516	3 Compartment Plate, 9"	43520	Nappie Bowl, 5 <sup>3</sup> / <sub>4</sub> ", 16 oz
43514	3 Compartment Plate, 9 <sup>3</sup> / <sub>4</sub> "	43563	Oval Platter, 9 <sup>1</sup> / <sub>4</sub> "x 6 <sup>1</sup> / <sub>4</sub> "
43512	3 Compartment Plate, 11"	43560	Oval Platter, 12"x 8 <sup>1</sup> / <sub>2</sub> "



## Kingline™ Melamine Dinnerware

- Medium weight melamine dinnerware
- Reinforced at vital stress points
- Fast drying
- Safe for temperatures up to 212°F
- Dishwasher safe
- Ask about available colors



NSF

Durable gloss finish resists chipping, scratching and staining

PK		PK	
KL205	Bread & Butter Plate, 5 <sup>1</sup> / <sub>2</sub> "	KL350	Bouillon Cup, 8 oz
KL201	Sandwich Plate, 7 <sup>1</sup> / <sub>4</sub> "	KL115	Chowder Bowl, 16 oz
KL204	Pie Plate, 6 <sup>1</sup> / <sub>2</sub> "	KL118	Nappie Bowl, 5 <sup>1</sup> / <sub>8</sub> ", 10 oz
KL200	Dinner Plate, 9"	KL108	Nappie Bowl, 5 <sup>1</sup> / <sub>2</sub> ", 14 oz
KL920	Dinner Plate, 9"	KL119	Rimmed Nappie Bowl, 5 <sup>1</sup> / <sub>2</sub> ", 12 <sup>1</sup> / <sub>2</sub> oz
KL116	Dinner Plate, 10"	KL924	Rimmed Nappie Bowl, 5 <sup>1</sup> / <sub>2</sub> ", 12 <sup>1</sup> / <sub>2</sub> oz
KL102	3 Compartment Plate, 10"	KL121	Grapefruit Bowl, 5 <sup>7</sup> / <sub>8</sub> ", 10 oz
KL127	Oval Platter, 12" x 9"	KL805	Fruit Bowl, 4 <sup>1</sup> / <sub>2</sub> ", 4 <sup>3</sup> / <sub>4</sub> oz
KL126	Oval Platter, 13 <sup>1</sup> / <sub>2</sub> " x 9 <sup>3</sup> / <sub>4</sub> "	KL928	Fruit Bowl, 4 <sup>1</sup> / <sub>2</sub> ", 4 <sup>3</sup> / <sub>4</sub> oz



SUPPLIER SPOTLIGHT

# SUPPLIER SPOTLIGHT

## SAN Stackable™ Tumblers

- Durable SAN Plastic reduces breakage
- Tapered sides make tumblers easy to stack and pull apart
- Stacking lugs inside prevent jamming when stored
- Dishwasher safe
- BPA free
- Colors: Amber (13), Clear (07), Ruby (10), Ice Blue (54) and Royal Blue (47)

5501	Tumbler, 5 oz, H3½" D1¼"	6 dz	5220	Tumbler, 20 oz, H6½" D2½"	6 dz
5526	Tumbler, 8 oz, H3⅞" D2"	6 dz	5224	Tumbler, 24 oz, H7⅞" D2⅞"	6 dz
5506	Tumbler, 9½ oz, H4⅞" D2⅞"	6 dz	5532	Tumbler, 32 oz, H6½" D3"	4 dz
5212	Tumbler, 12 oz, H5⅜" D2¼"	6 dz	5232	Tall Tumbler, 32 oz, H7⅞" D2⅞"	2 dz
5216	Tumbler, 16 oz, H5⅞" D2⅞"	6 dz			



Pebble textured exterior hides wear and tear



## Louis™ Tumblers

- Designed for healthcare tray, bar or room service
- Extra thick base mimics the look of glass, but is durable SAN
- Faceted body shape makes the tumblers easier to hold
- Chip, shatter, and break-resistant
- Clear, dishwasher safe
- BPA free
- Stackable
- Packed 2 dz

5806	Tumbler, 6 oz, H3½" D2⅞"	5816	Tumbler, 16 oz, H6" D3¼"
5808	Rocks, 8 oz, H3⅝" D3"	5820	Tumbler, 20 oz, H6¼" D3½"
5810	Tumbler, 10 oz, H4½" D2⅞"	5822	Tumbler, 22 oz, H6½" 3⅞"
5812	Rocks, 12 oz, H3⅞" D3½"	5832	Tumbler, 32 oz, H7¼" D4"
5814	Tumbler, 14 oz, H6" D3"		

## Alibi Drinkware

- Great for outdoor and poolside beverage service
- Barware is made from durable lightweight SAN and is BPA free
- Stemware is made from break-resistant polycarbonate
- Dishwasher safe
- Clear
- Packed 2 dz



### Barware

5601	Shot, 1½ oz, H2½" D1⅝"
5602	Shooter, 2 oz, H2¾" D1⅞"
5603	Shooter/Mini Dessert, 3 oz, H3⅝" D2⅞"
5609	Rocks/Juice, 9 oz, H3⅞" D3¼"
5610	Highball, 10 oz, H5⅞" D2⅞"
5612	Double Old Fashioned, 12 oz, H3¾" D3⅞"
5614	Beverage, 10 oz, H6¼" D2⅞"
5616	Pint/Mixing, 16 oz, H5⅞" D3⅞"

### Stemware

5640	Champagne Flute, 8 oz, H9¼" D2¾"
5641	Balloon, 22 oz, H8¼" D4¼"
5642	Red Wine, 20 oz, H9" D3¾"
5643	White Wine, 11 oz, H9" D3¾"



## Mingle Drinkware

- The look and feel of recycled glass drinkware
- Made of BPA Free Tritan
- Durable Tritan material will not crack or develop craze lines
- Dishwasher safe
- 2 year warranty
- Colors: Clear (07), Teal (15) and Smoke (18)

		PK
MIN5440	Double Old Fashioned, 14 oz, H4¼" D3⅞"	1 dz
MIN5441	Juice Cup, 6 oz, H3¾" D2½"	1 dz
MIN5442	Highball, 19 oz, H5½" D3⅞"	1 dz
MIN5443	Pitcher, 74 oz, H9½" D5¼"	4 ea



## Bay Point China

- Narrow rim body
- Subtle embossing and vibrant colors add distinction to any tabletop
- Each case contains an even mixture of all available colors

- Carefree eclectic look is achieved instantly without the cost or hassle of keeping multiple cases of each color
- BPSET includes 6 ea - 7½" & 10¼" plates, 15 oz nappies and 8½ oz mugs

		PK			PK
BP42	Plate, 6⅝"	3 dz	BP61	Rim Soup Bowl, 9"	2 dz
BP43	Plate, 7½"	3 dz	BP12	Bouillon Cup, 8 oz	3 dz
BP44	Plate, 9"	2 dz	BP31	Fruit Dish, 4 oz	3 dz
BP46	Plate, 10½"	1 dz	BP34	Nappie, 15 oz	3 dz
BP47	Plate, 12"	1 dz	BP36	Nappie, 30 oz	1 dz
BP50	Oval Platter, 7"	2 dz	BP16	Mug, 8½ oz	3 dz
BP51	Oval Platter, 9⅝"	2 dz	BP21	Saucer, 6"	3 dz
BP52	Oval Platter, 11½"	2 dz	BPSET	24 Piece Set	2 sets
BP53	Oval Platter, 13½"	1 dz			

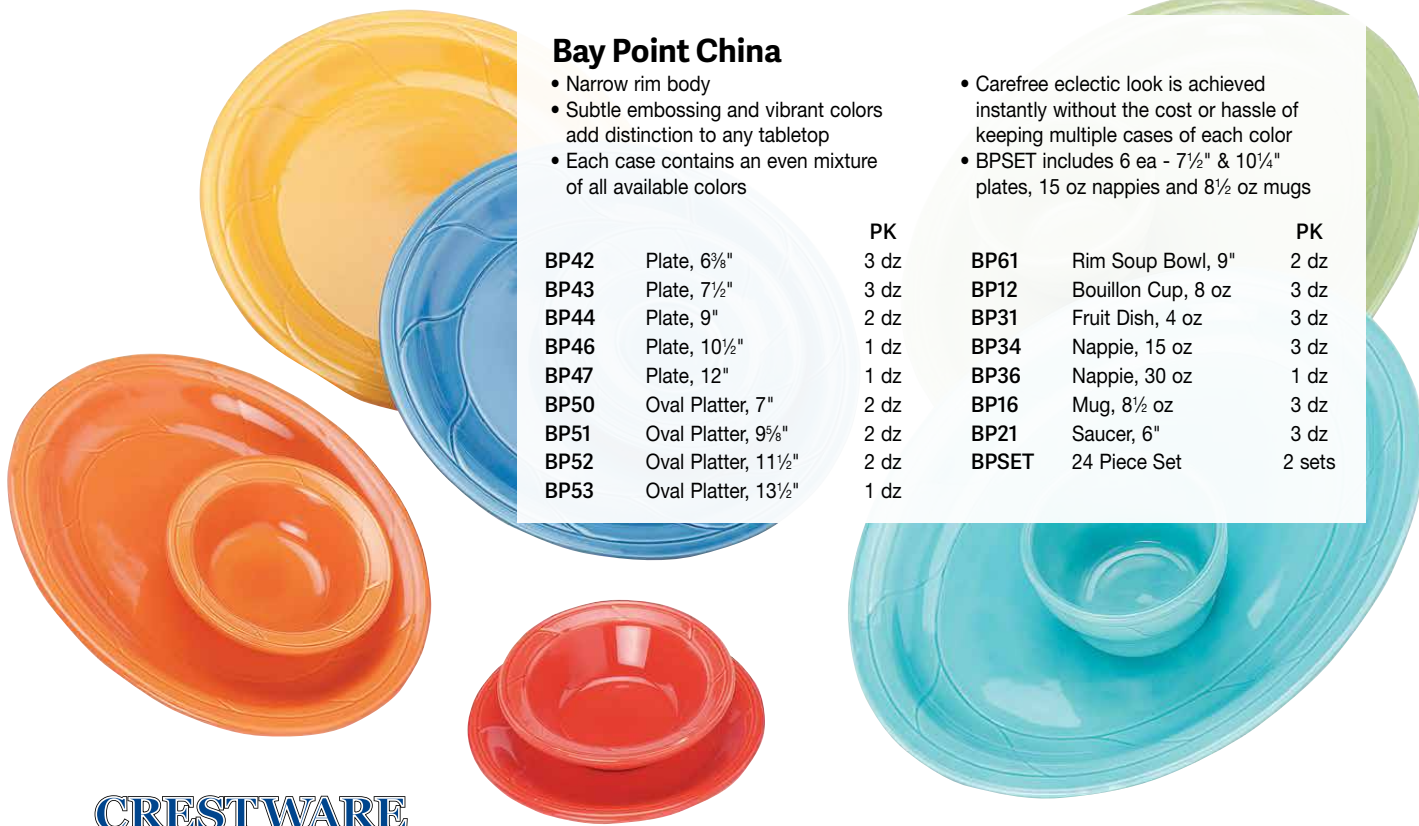

CRESTWARE

# SUPPLIER SPOTLIGHT

## Dover White China

- Color interchanges with classic pattern
- Vitrified, dishwasher, oven, microwave safe
- Exceptional durability
- Chip-resistant narrow rim body
- American/bone white (unless noted)

		PK
CM41	Plate, 5½"	3 dz
CMSQ8	Square Plate, 8"	2 dz
CM51	Oval Platter, 9½"	2 dz
CM96	Casserole Dish, 9 oz, 4¼" x 6"	2 dz
CM12	Bouillon, 7½ oz	3 dz
CM31	Fruit Bowl, 4 oz, 4⅞"	3 dz
CM32	Grapefruit Bowl, 9 oz, 6¼"	3 dz
CM33	Nappie, 12 oz, 5⅞"	3 dz
CM60	Rim Soup Bowl, 8 oz, 8"	3 dz
CM28	Rice Bowl, 24 oz, 6"	3 dz
CM70	Pasta Bowl, 9⅞"	1 dz
CM4BR	Soup Crock, 16 oz, 5½", Brown	2 dz
CM40SC	Onion Soup Crock, 10 oz, 4⅞" x 5"	3 dz
CM92	Rarebit, 8 oz, 8½" x 4⅞"	4 dz
CM09	Saucer, 4"	3 dz
CM10	Cup, Cuban, 3½ oz	3 dz
CM11	Cup, Tall, 7 oz	3 dz
CM41W	Mug, 7½ oz, White	3 dz
CM16	Brawny Mug, 8½ oz	3 dz
CM68	Sugar Packet Holder, 3⅞" x 2⅞"	4 dz
CMS&P	S&P Shakers, 2 oz, 2"	4 dz
CM81	Ramekin, 2½ oz	4 dz

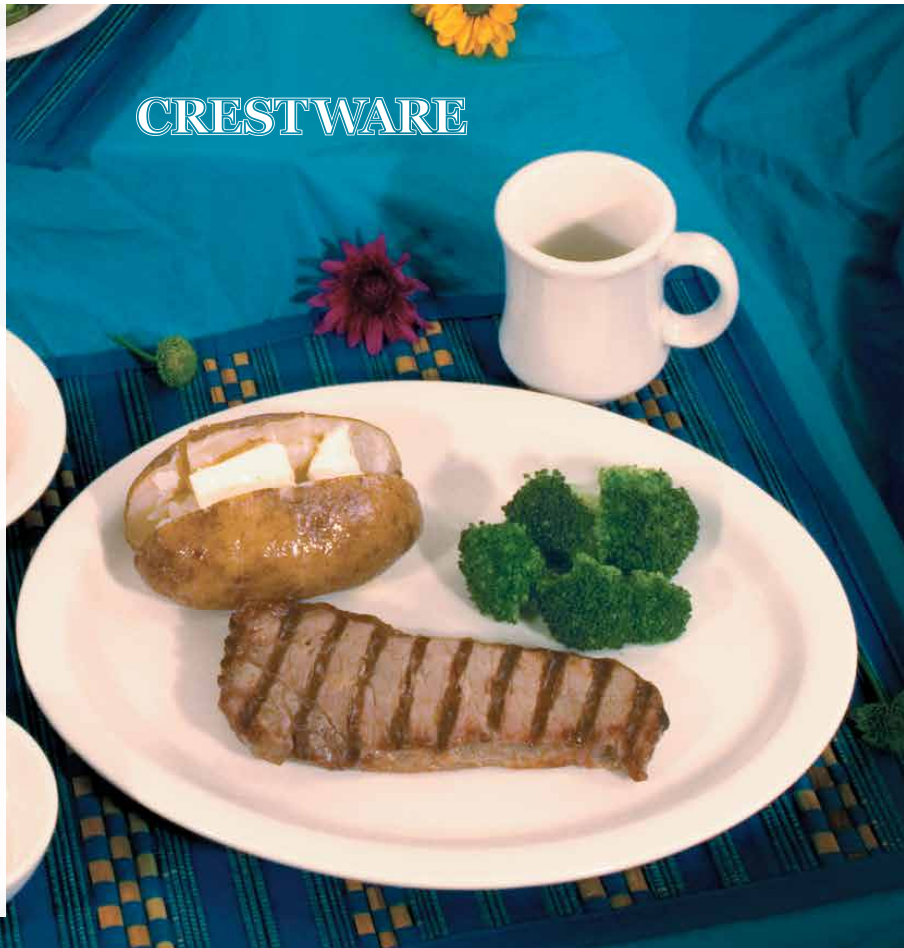

## Alpine White China

- The crisp white look of this European classic is now an American favorite
- Narrow rim shape
- Vitrified
- Oven & microwave safe
- Porcelain color

		PK
AL41	Plate, 5½"	3 dz
AL48	Plate, Wide Rim, 11"	1 dz
AL51	Oval Platter, 9½"	2 dz
AL12	Bouillon, 7½ oz, 4"	3 dz
AL31	Fruit Bowl, 4 oz, 4⅞"	3 dz
AL32	Grapefruit Bowl, 9 oz, 6½"	3 dz
AL33	Nappie, 12 oz, 5⅞"	3 dz
AL38	Nappie, Footed, 42 oz, 9"	1 dz
AL28	Rice Bowl, 24 oz, 5⅞"	3 dz
AL35	Bowl, Rimmed, 14 oz, 7½"	3 dz
AL61	Rim Soup Bowl, 12 oz, 9"	2 dz
AL39	Soup/Pasta Bowl, 15 oz, 10½"	1 dz
AL92	Rarebit, 8 oz, 4¼" x 8½"	3 dz
AL19	Saucer, 4⅞"	3 dz
AL10	Cup, AD, 3½ oz	3 dz
AL11	Cup, Tall, 7 oz	3 dz
AL16	Mug, Coffee, 8½ oz	3 dz
AL15	Mug, Stackable, 10 oz	3 dz
AL74	Teapot, 14 oz	1 dz
AL72	Creamer, 3¾ oz	3 dz
AL77	Ramekin, 5 oz	3 dz
AL78	Souffle/Ramekin, 10 oz, 4½"	3 dz